



Boise Cascade
Engineered Wood Products

STAIR STRINGER GUIDE

1½" VERSA-LAM® 1.7 2650



Lifetime Guaranteed Quality and Performance

Boise warrants its BCI® Joist, VERSA-LAM®, and ALLJOIST® products to comply with our specifications, to be free from defects in material and workmanship, and to meet or exceed our performance specifications for the-normal and expected life of the structure when correctly stored, installed-and used according to our Installation Guide.

Boise EWP is a participant in the Sustainable Forestry Initiative® (SFI®), a comprehensive forest management program that is a combination of environmental responsibilities and sound business practices. The procurement systems of Boise Cascade's engineered wood product facilities have been audited by PricewaterhouseCoopers to the SFI® Standard and its products will carry the SFI® Label. These procurement systems provide tracking information on Boise Cascade's supply chain sources.



For information about Boise's engineered wood products, including sales terms and conditions, warranties and disclaimers,

visit our website at www.BC.com/ewp
email us at EWPIInfo@bc.com or call us at 800-232-0788

1½" VL 1.7 2650 East
Stair Stringer Guide
05/2008

1½" VERSA-LAM® 1.7 2650 Allowable Stair Stringer Spans

Material Depth	36" Tread Width				42" Tread Width		44" Tread Width		48" Tread Width	
	2 Stringers		3 Stringers		3 Stringers		3 Stringers		3 Stringers	
	Stringer Run	Total Rise	Stringer Run	Total Rise	Stringer Run	Total Rise	Stringer Run	Total Rise	Stringer Run	Total Rise
40 PSF Live Load / 12 PSF Dead Load										
9½"	6'-2"	6'-1"	7'-0"	6'-10"	6'-8"	6'-7"	6'-7"	6'-6"	6'-4"	6'-4"
11⅞"	10'-0"	9'-7"	11'-5"	10'-10"	10'-10"	10'-4"	10'-8"	10'-2"	10'-5"	9'-11"
14"	13'-6"	12'-8"	15'-5"	14'-4"	14'-8"	13'-8"	14'-5"	13'-6"	14'-0"	13'-2"
100 PSF Live Load / 12 PSF Dead Load										
9½"	4'-7"	4'-9"	5'-2"	5'-3"	4'-11"	5'-1"	4'-10"	5'-0"	4'-9"	4'-10"
11⅞"	7'-6"	7'-4"	8'-6"	8'-3"	8'-1"	7'-10"	8'-0"	7'-9"	7'-9"	7'-7"
14"	10'-1"	9'-7"	11'-6"	10'-10"	10'-11"	10'-4"	10'-9"	10'-3"	10'-5"	9'-11"

SPAN/LOADING NOTES

- Deflection limited to L/360 live load & L/240 total load.
- Spans based upon a stair limits of 8" max rise and 9" min. run, governing building codes may be more restrictive.
- Contact Boise EWP Engineering for design assistance on other stair stringer applications and/or loading.

- Consult governing building code and/or local building official for proper live load per application.
- Building codes typically restrict stair widths to 44" or greater for stairways serving an occupant load greater than 50 people.
- Maximum total rise between floors is 12'-0" per building codes.

SPAN TABLE DETAILS

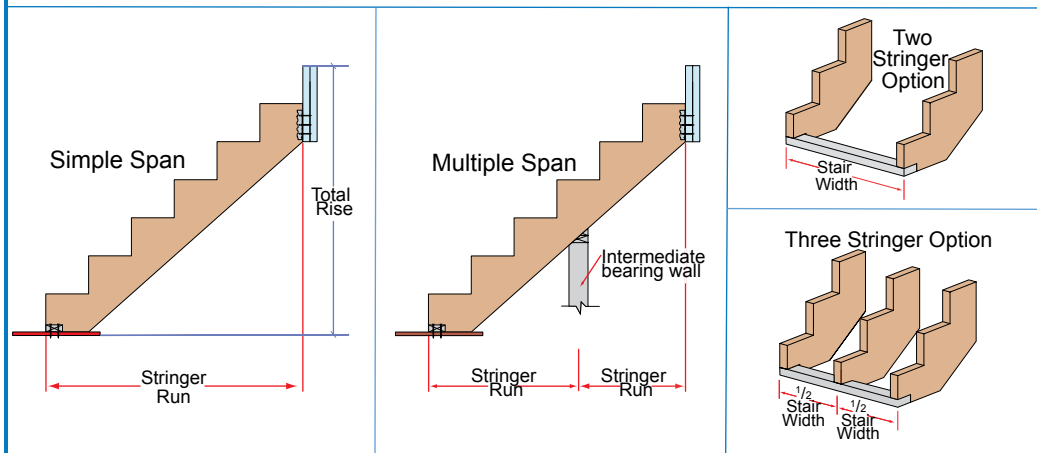

ALLOWABLE CUT DIMENSIONS

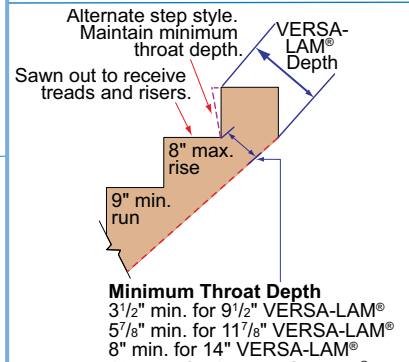

CONNECTION DETAILS - For 40 PSF Live Load Applications Only (Consult design professional of record for connections of 100 PSF applications.)

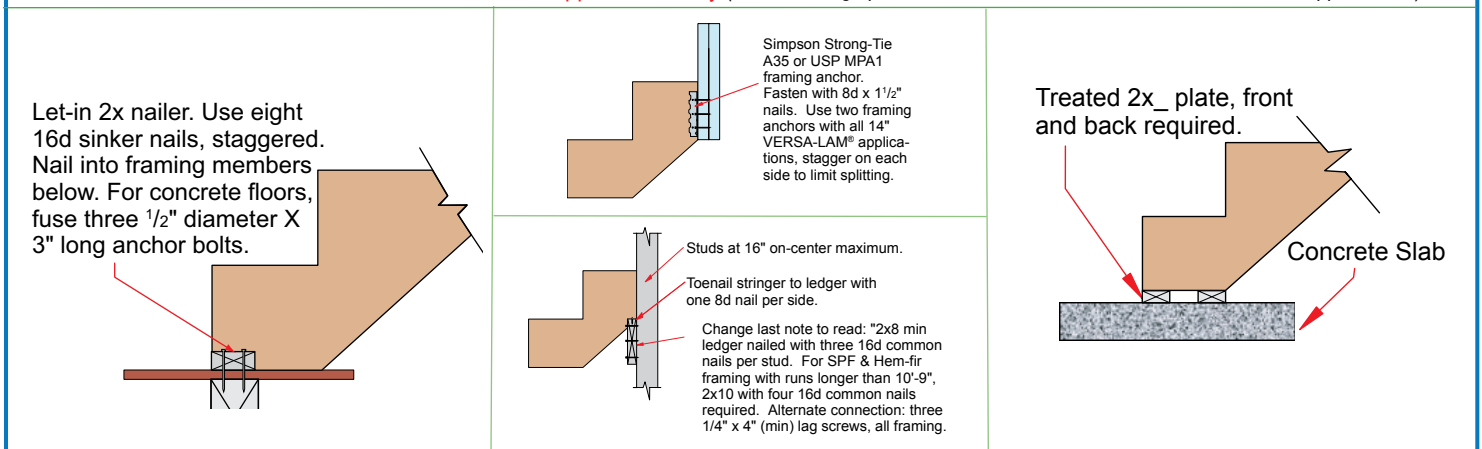

DO NOT overcut stair stringer

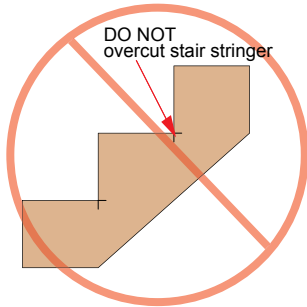

DO NOT support stringer on notch detail

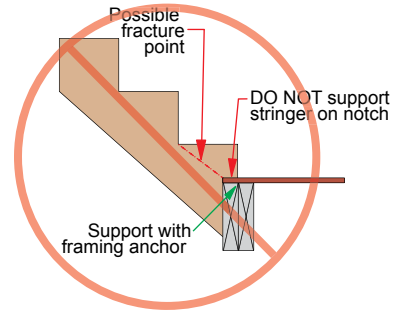

DO NOT support stringer on let-in nailer only

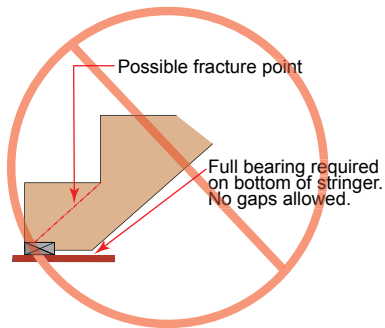

DO NOT use shallow header depths

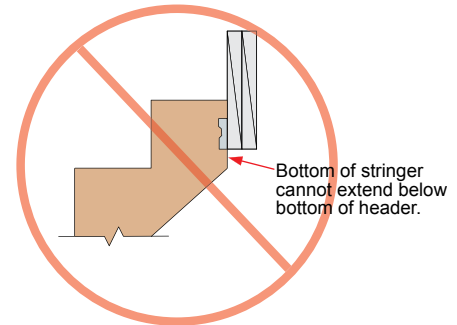

CONSTRUCTION NOTES

- Stair stringers are extremely unstable, use caution when installing treads.
- Use subfloor adhesive on all contact surfaces to minimize squeaks.
- Adequate moisture barrier required between stringers and concrete.
- Keep product as dry as possible during construction.
- All wood splits when significant stress is induced across the grain - DO NOT apply significant side impact load (e.g., hammer) to remaining triangle sections of stringers.
- When installing treated wood, use only connectors/fasteners that are approved for use with the corresponding wood treatment.
- Use fasteners no larger than 8d box nail or 8d wood screw for attaching standard treads, space no closer than 3" on-center.

1½" VERSA-LAM® 1.7 2650 Allowable Design Values

Modulus of Elasticity E [psi]	Bending F _b [psi]	Horizontal Shear F _v [psi]	Compression Parallel to Grain F _c [psi]	Compression Perpendicular to Grain F _c [psi]	Tension Parallel to Grain F _t [psi]
1,700,000	2650 ⁽¹⁾	285	3000	750	1650

1) Multiply by depth factor: (12/d)^{1/9}

SUPER STEP®

SUPER STEP® INSTALLATION INSTRUCTIONS

1. SUPER STEP® stair tread is for interior application only. It should be kept dry during storage and construction.
2. SUPER STEP® stair tread shall be covered with carpeting or other finish flooring material.
3. Stringers should be installed using conventional framing and fastening practices with a maximum distance of 42" between stringers.
4. SUPER STEP® stair tread shall be installed using conventional framing and fastening practices that are in compliance with all applicable code requirements. In addition, structural adhesives must be used in combination with nailing.
5. In all installations, each SUPER STEP® stair tread must be supported at both front and back by a full length ¾" (minimum) solid wood or structural grade plywood riser which is fastened with both nails and structural adhesives. The back support shall be nailed (with adhesive) through the back face of the adjoining riser and into the center of the back edge of the SUPER STEP® stair tread.
6. Stairs where entries may be subject to wet foot traffic should have the treads protected with a waterproof wearing surface such as linoleum or vinyl floor covering. When carpeting is used in these areas, the tread shall be protected with suitable moisture-resistant coating before installation of carpet.

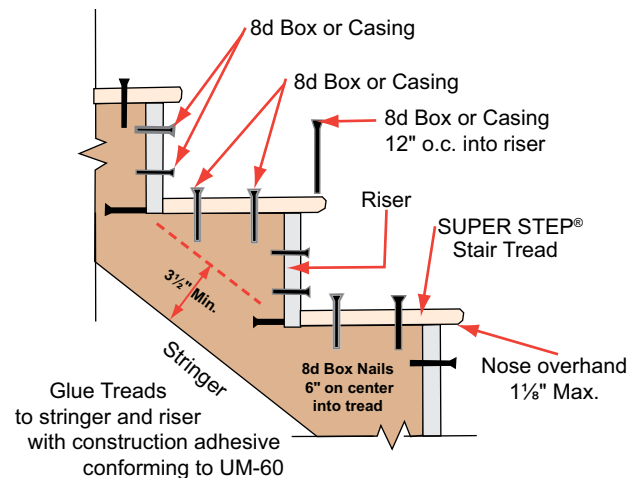
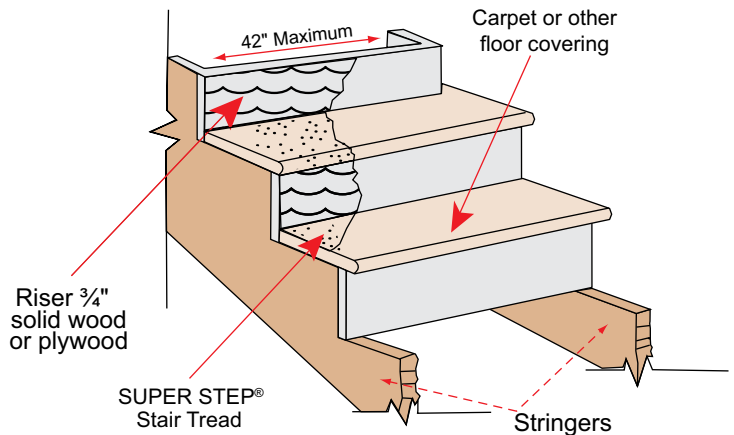

MANUFACTURING STANDARDS Average	IMPERIAL	METRIC
Thickness - Nominal	1 1/8 inches	28.5 mm
Width	11 1/4 inches	28.56 mm
Lengths - other lengths available upon request	6', 8', 10', 12'	1.83m, 2.44m, 3.05m, 3.66m
Length: Standard (6', 8', 10', 12')	Up to +1 inches	25.4 mm
Custom	Up to +1/4 inches	6.35 mm
Weight / MSF	4,500 lbs	2,035 Kg
Packaging - Pieces per unit	44	44
Modulus of Rupture	2,400 psi	16.55 N/mm ²
Modulus of Elasticity	420,000 psi	2,896 N/mm ²
Internal Bond	90 psi	0.62 N/mm ²
Hardness	900 lbs	4,003 N
Formaldehyde, Emissions	< 0.3 ppm	< 0.3 ppm
Linear Expansion - Maximum	0.35%	0.35%
Water Absorption - Maximum	20.0%	20.0%
Thickness Swell - Maximum	0.035 inches	0.889 mm
Moisture Content	7.0%	6.8%
Target Thickness	±0.005 inches	0.127 mm
Sanding	100 grit	

THICKNESS RANGE

1 1/8" Only

DESCRIPTION

An engineered composite wood product cut into strips of standard width and custom lengths with one long edge bullnosed.

SPECIFICATION CONFORMANCE

The manufacturing standards shown on the left represent an average of all our product thicknesses. Conforms to American Society of Testing and Materials Fire Test Method E-84 (flamespread rating is Class C).



Boise Cascade
Engineered Wood Products

For more information about BOISE PARTICLE-BOARD, including sales terms and conditions, visit our website at

www.bc.com/particleboard
TWParticleboardSales@BC.com
888-264-7372

