



ALLJoist®

SPECIFIER GUIDE

INCLUDES AJS® 140 / 20 / 25 &
VERSA-LAM® BEAMS

The information in this document pertains to use in the UNITED STATES ONLY, Allowable Stress Design. Refer to the ALLJOIST Specifier Guide Canada for use in Canada, Limit States Design.

Introducing AJS® 25 18" - 24" Depths



US Version

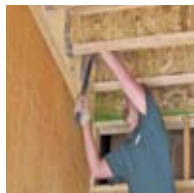

Boise Cascade
Engineered Wood Products





Makes Designing Homes Easier

Architects, engineers, and designers trust Boise's engineered wood products to provide a better system for framing floors and roofs.

It's the SIMPLE FRAMING SYSTEM®, featuring beams, joists and rim boards that work together as a system, so you spend less time cutting and fitting. In fact, the SIMPLE FRAMING SYSTEM® uses fewer pieces and longer lengths than conventional framing, so you'll complete jobs in less time.

You'll Build Better Homes with the SIMPLE FRAMING SYSTEM®

Now it's easier than ever to design and build better floor systems. When you specify the SIMPLE FRAMING SYSTEM®, your clients will have fewer problems with squeaky floors and ceiling gypsum board cracks. The SIMPLE FRAMING SYSTEM® also means overall better floor and roof framing than dimension lumber allows.

Better Framing Doesn't Have to Cost More

Boise Engineered Wood Products' SIMPLE FRAMING SYSTEM® often costs less than conventional framing methods when the resulting reduced

labor and materials waste are considered. There's less sorting and cost associated with disposing of waste because you order only what you need. Although our longer lengths help your clients get the job done faster, they cost no more.

Environmentally Sound

As an added bonus, floor and roof systems built with AJS® Joists require about half the number of trees as those built with dimension lumber. This helps you design a home both you and future generations will be proud to own.

What Makes the SIMPLE FRAMING SYSTEM® So Simple?

☑ Floor and Roof Framing with ALLJOIST® Product

Light in weight, but heavy-duty, ALLJOIST® Product (AJS® Joists) have a better strength / weight ratio than dimension lumber. Knockouts can be removed for cross-ventilation and wiring.

☑ Ceilings Framed with AJS® Joists

The consistent size of AJS® Joists helps keep gypsum board flat and free of unsightly nail pops and ugly shadows, while keeping finish work to a minimum.

☑ VERSA-LAM® Beams for Floor and Roof Framing

These highly-stable beams are free of the large-scale defects that plague dimension beams. The result is quieter, flatter floors (no camber) and no shrinkage-related call-backs.

☑ Boise Rimboard

Boise Engineered Wood Products offer several engineered rimboard products regionally, including BC RIM BOARD® OSB, BC RIM BOARD® and VERSA-RIM® (check supplier or Boise EWP representative for availability). These products work with AJS® Joists to provide a solid connection at the critical floor/wall intersection.

ALLJOIST® Product Profiles, Architectural Specifications 3
 About Floor Performance, AJS® Residential Floor Span Tables, One Hour Floor/Ceiling Assembly 4
 AJS® Floor Framing Details 5 - 6
 AJS® Joist Hole Location and Sizing 7
 AJS® Cantilever Table/Details 8 - 10
 Web Stiffener Requirements 10
 Large Rectangular Holes in AJS® Joists 10
 AJS® Floor Load Tables 11 - 12
 AJS® Roof Framing Details 13 - 14
 AJS® Roof Span Tables 15 - 17
 AJS® Roof Load Tables 18 - 20
 AJS® Design Properties, 21

Boise Rimboard Products 22
 VERSA-LAM® Products, Specifications, Allowable Holes 23
 VERSA-LAM® Details, Multiple Member Connectors 24
 VERSA-LAM® Floor Load Tables (100% Load Duration) 25
 VERSA-LAM® Snow Roof Load Tables (115% Load Duration) 26
 VERSA-LAM® Non-Snow Roof Load Tables (125% Load Duration) ... 27
 VERSA-LAM® Allowable Nailing and Design Values 28
 VERSA-LAM® Columns, VERSA-STUD® 29
 Computer Software 30
 BC Column™ Software 31
 Framing Connectors - Simpson 32 - 33
 Framing Connectors - USP 34 - 35
 Lifetime Guarantee Back Cover

AJS® 140

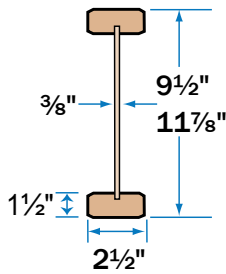

AJS® 20

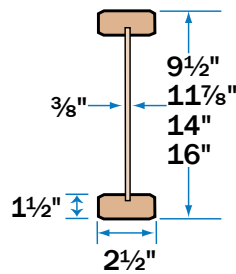

AJS® 25

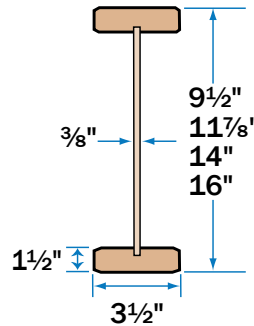

AJS® 25 Deeper Depths

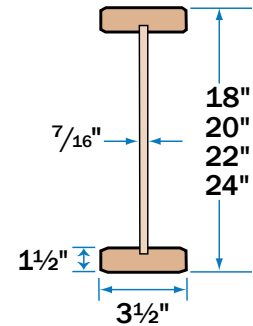

ALLJOIST® Product Architectural Specifications

EVALUATION SUBJECT: AJS Series Prefabricated Wood I-Joists

1.0 Evaluation Scope:

Compliance with the following codes:

- International Building Code (IBC)
- International Residential Code (IRC)

Properties Evaluated: Structural.

2.0 Uses: The AJS® Series prefabricated wood I-joists are used as floor joists and blocking panels to support floor design loads.

3.0 Description:

3.1 General: The AJS Series prefabricated wood I-joists have solid-sawn lumber or composite lumber flanges and oriented strand board (OSB) webs. The top and bottom flanges are parallel, creating constant-depth joists. The web-to-web joints of the I-joists are square butt joints and conform to the specifications in the approved quality control manuals. The web-to-flange connection is a proprietary grooved connection, also conforming to the approved quality control manuals. The I-joists are available in various lengths and depths. See ESR-1144 Table 1 for full description of the AJS I-Joist.

3.2 Material Specifications:

3.2.1 Flanges: The flanges of the I-joists are sawn lumber or composite lumber conforming to the specifications in the approved quality control manuals. The sawn lumber flange material, grade, width and depth are noted in ESR-1144, Table 1.

3.2.2 Web: Web material for the I-Joists is 5/8-inch-thick (10mm) or 7/16-inch-thick (11mm) OSB conforming to Exposure 1 requirements of PS-2, with further requirements set forth in the approved quality control manuals and manufacturing standards.

3.2.3 Adhesive: Adhesives used in the fabrication of the I-joists comply with ASTM D 2559, and are specified in the quality control manuals and the manufacturing standards.

4.0 Design and Installation: Design of the prefabricated wood I-joists described in this report shall be in accordance with the applicable code. Additionally, the design and installation of the prefabricated wood I-joists shall comply with Sections 4.1 through 4.12 listed in ESR-1144 which include 4.1 Allowable Structural Capacity, 4.2 Fasteners, 4.3 Web Stiffeners, 4.4 Lateral Support, 4.5 Holes in I-Joist Web, 4.6 Duration of Load, 4.7 In-Service Moisture Conditions, 4.8 Repetitive-Member Use, 4.9 Member Spans, 4.10 Deflection, 4.11 Blocking Panels, & 4.12 Cantilevered Joists, and the manufacturer's installation instructions.

5.0 Conditions of Use: The AJS Series I-joists described in this report comply with, or are suitable alternatives to what is specified in, those codes listed under 1.0 Evaluation Scope of these specifications, subject to the following conditions:

5.1 For applications based on ESR-1144 Table 2, Allowable Design Properties for Alljoist I-Joists, design calculations and details for specific applications shall be

furnished to the code official. Calculations and drawings shall be prepared, signed and sealed by a registered design professional where required by the statutes of the jurisdiction in which the project is to be constructed.

5.2 Flanges of the I-joists shall not be cut or notched.

5.3 The I-joists are produced by Boise Cascade Alljoist Ltd at their plant in St. Jacques, New Brunswick, Canada. Quality control inspections are conducted by PFS Corporation.

6.0 Evidence Submitted:

- 6.1 Manufacturer's installation instructions.
- 6.2 Quality control manuals.
- 6.3 Data in accordance with the ICC-ES Acceptance Criteria for Prefabricated Wood I-joists (AC14), dated June 2004.

7.0 Identification:

AJS I-joists are identified by a stamp indicating the joist model, company name (Boise Cascade Alljoist Ltd.); evaluation report number (ESR-1144); and the name and logo of the inspection agency (PFS).

AJS Joists in Commercial Projects: The new deeper depth AJS® 25 joists are intended for commercial projects with heavier design loads and longer spans. All commercial projects utilizing AJS® joists shall have an engineer or architect of record.



Boise Cascade
Engineered Wood Products

About Floor Performance

Homeowner's expectations and opinions vary greatly due to the subjective nature of rating a new floor. Communication with the ultimate end user to determine their expectation is critical. **Vibration** is usually the cause of most complaints. Installing lateral bridging may help; however, squeaks may occur if not installed properly. Spacing the joists closer together does little to affect the perception of the floor's performance. The most common methods used to increase the performance and reduce vibration of wood floor systems is to

increase the joist depth, limit joist deflections, glue and screw a thicker, tongue-and-groove subfloor, install the joists vertically plumb with level-bearing supports, and install a direct-attached ceiling to the bottom flanges of the joists.

The floor span tables listed below offer three very different performance options, based on performance requirements of the homeowner.

Joist Depth	ALLJOIST® Series	★★★THREE STAR ★★★				★★★★FOUR STAR★★★★				CAUTION	★MINIMUM STIFFNESS ALLOWED BY CODE★				CAUTION		
		<p>Live Load deflection limited to L/480: The common industry and design community standard for residential floor joists, 33% stiffer than L/360 code minimum. However, floor performance may still be an issue in certain applications, especially with 9½" and 11⅞" deep joists without a direct-attached ceiling.</p> <p>Live Load deflection limited to L/960+: A floor that is 100% stiffer than the three star floor. A premium floor that 100% stiffer than the 3 star floor for the discriminating homeowner.</p> <p>Live Load deflection limited to L/360: Floors that meet the minimum building code L/360 criteria are structurally sound to carry the specified loads; however, there is a much higher risk of floor performance issues. This table should only be used for applications where floor performance is not a concern.</p>															
		12" o.c.	16" o.c.	19.2" o.c.	24" o.c.	12" o.c.	16" o.c.	19.2" o.c.	24" o.c.	12" o.c.	16" o.c.	19.2" o.c.	24" o.c.	12" o.c.	16" o.c.	19.2" o.c.	24" o.c.
9½"	140	17'-9"	16'-3"	15'-4"	13'-10"	13'-10"	12'-8"	11'-11"	11'-1"	19'-7"	17'-0"	15'-6"	13'-10"				
	20	19'-0"	17'-5"	16'-5"	15'-3"	14'-10"	13'-6"	12'-9"	11'-10"	21'-1"	19'-3"	18'-2"	16'-4"				
	25	20'-8"	18'-10"	17'-9"	16'-7"	16'-1"	14'-8"	13'-9"	12'-9"	22'-10"	20'-10"	19'-8"	18'-1"				
11⅞"	140	21'-2"	19'-4"	17'-8"	15'-9"	16'-6"	15'-1"	14'-2"	13'-2"	22'-5"	19'-4"	17'-8"	15'-9"				
	20	22'-8"	20'-8"	19'-6"	18'-2"	17'-8"	16'-1"	15'-2"	14'-1"	25'-1"	22'-10"	20'-10"	18'-7"				
	25	24'-7"	22'-5"	21'-2"	18'-3"	19'-2"	17'-5"	16'-5"	15'-3"	27'-2"	24'-10"	22'-10"	18'-3"				
14"	20	25'-8"	23'-6"	22'-2"	19'-1"	20'-1"	18'-4"	17'-3"	16'-0"	28'-5"	25'-1"	22'-10"	19'-1"				
	25	27'-10"	25'-5"	22'-11"	18'-4"	21'-9"	19'-9"	18'-7"	17'-3"	30'-10"	27'-7"	22'-11"	18'-4"				
16"	20	28'-6"	26'-0"	24'-1"	19'-3"	22'-3"	20'-3"	19'-1"	17'-9"	31'-2"	27'-0"	24'-1"	19'-3"				
	25	30'-10"	27'-10"	23'-2"	18'-6"	24'-1"	21'-11"	20'-8"	18'-6"	34'-1"	27'-10"	23'-2"	18'-6"				
18"	25	34'-5"	31'-5"	29'-8"	27'-7"	27'-0"	24'-7"	23'-2"	21'-6"	38'-1"	34'-9"	32'-4"	28'-11"				
20"	25	37'-4"	34'-0"	32'-1"	29'-11"	29'-3"	26'-7"	25'-1"	23'-3"	41'-3"	37'-6"	34'-2"	30'-7"				
22"	25	40'-1"	36'-7"	34'-6"	32'-0"	31'-5"	28'-7"	26'-11"	25'-0"	44'-3"	39'-3"	35'-10"	32'-0"				
24"	25	42'-10"	39'-0"	36'-10"	33'-5"	33'-7"	30'-7"	28'-9"	26'-9"	47'-3"	40'-11"	37'-4"	33'-5"				

- Table values based on residential floor loads of 40 psf live load and 10 psf dead load (12 psf dead load for AJS® 25 joists).
- Table values assume that 23/32" min. plywood/OSB rated sheathing is glued and nailed to joists.
- Table values represent the most restrictive of simple or multiple span applications.
- Table values are the maximum allowable clear distance between supports. Analyze multiple span joists with BC CALC® sizing software if the length of any span is less than half the length of an adjacent span.

- Table values assume minimum bearing lengths without web stiffeners for joist depths of 16" inches and less (18" joists and deeper require web stiffeners at all bearing locations).
- Floor tile will increase dead load and may require specific deflection limits, contact Boise EWP Engineering for further information.
- This table was designed to apply to a broad range of applications. It may be possible to exceed the limitations of this table by analyzing a specific application with the BC CALC® sizing software.

Shaded values do not satisfy the requirements of the North Carolina State Building Code. Refer to the THREE STAR table when spans exceed 20 feet.

One-Hour Floor/Ceiling Assembly

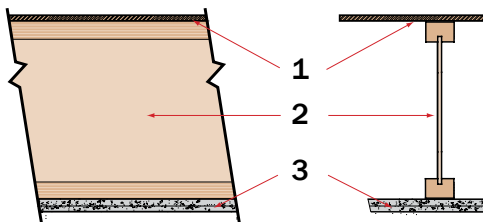

FIRE ASSEMBLY COMPONENTS

1. Min. 3/4" tongue-and-groove plywood or 23/32" APA Rated Sheathing (Exposure 1 or exterior glue)
2. AJS® Joists at 24" o.c. or less.
3. Two layers 1/2" Type C or two layers 5/8" Type X gypsum board
4. When constructed with resilient channels, STC = 50.

Contact your local Boise Cascade representative for specific assembly information and other fire-resistive options.

AJS® Joists

NOTE

The illustration below is showing several suggested applications for the Boise EWP products. It is not intended to show an actual house under construction.

NO MIDSPAN BRIDGING IS REQUIRED FOR ALLJOIST® PRODUCT

FOR INSTALLATION STABILITY, Temporary strut lines (1x4 min.) 8' on center max. Fasten at each joist with 2-8d nails minimum.

Dimension lumber is not suitable for use as a rim board in ALLJOIST® floor systems.

AJS® rim joist. See page 6.

Boise Rimboard. See pages 6 and 22.

For load bearing cantilever details, see page 9.

AJS® blocking or 2x4 "squash" block on each side required when supporting a load-bearing wall above.

When installing Boise EWP products with treated wood, use only connectors/fasteners that are approved for use with the corresponding wood treatment.

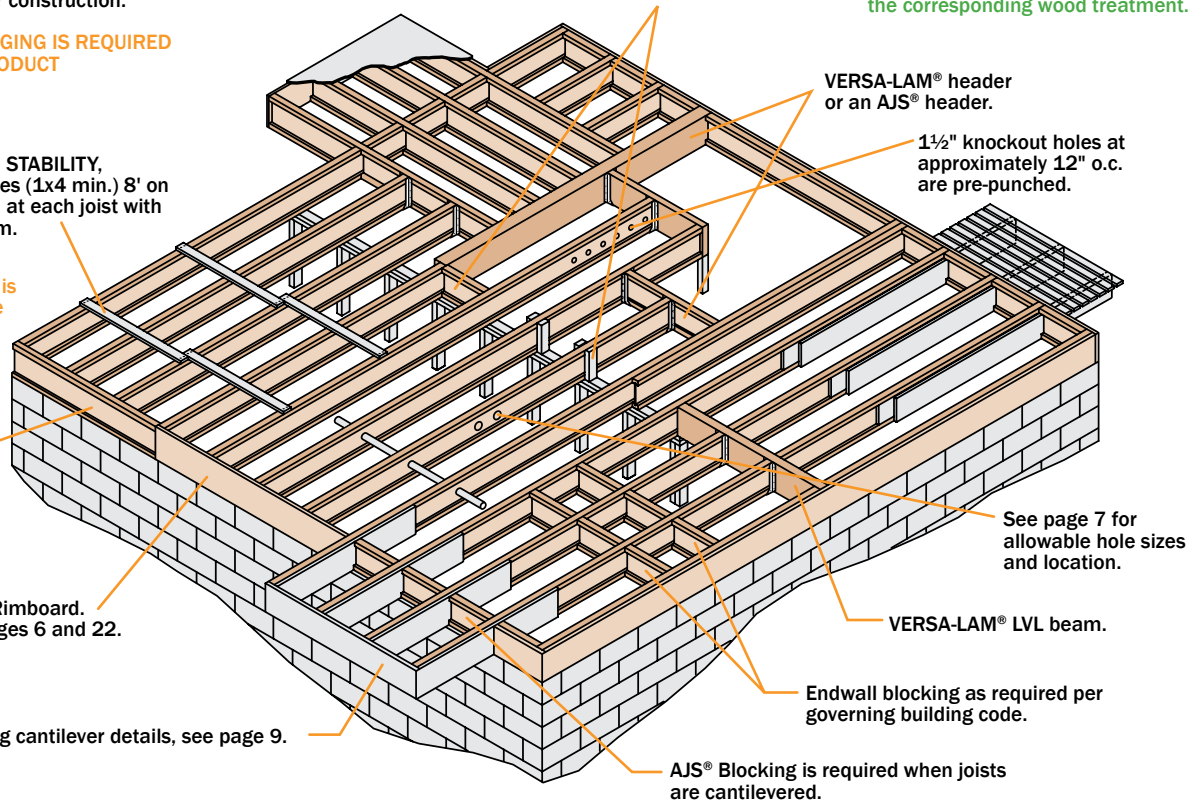

BCI® Joists, VERSA-LAM® and ALLJOIST® must be stored, installed and used in accordance with the Boise EWP Installation Guide, building codes, and to the extent not inconsistent with the Boise EWP Installation Guide, usual and customary building practices and standards. VERSA-LAM®, ALLJOIST®, and BCI® Joists must be wrapped, covered, and stored off of the ground on stickers at all times prior to installation. VERSA-LAM®, ALLJOIST® and BCI®

Joists are intended only for applications that assure no exposure to weather or the elements and an environment that is free from moisture from any source, or any pest, organism or substance which degrades or damages wood or glue bonds. Failure to correctly store, use or install VERSA-LAM®, ALLJOIST®, and BCI® Joist in accordance with the Boise EWP Installation Guide will void the limited warranty.

SAFETY WARNING

DO NOT ALLOW WORKERS ON AJS® JOISTS UNTIL ALL HANGERS, AJS® RIM JOISTS, RIM BOARDS, AJS® BLOCKING PANELS, X-BRACING AND TEMPORARY 1x4 STRUT LINES ARE INSTALLED AS SPECIFIED BELOW. SERIOUS ACCIDENTS CAN RESULT FROM INSUFFICIENT ATTENTION TO PROPER BRACING DURING CONSTRUCTION. ACCIDENTS CAN BE AVOIDED UNDER NORMAL CONDITIONS BY FOLLOWING THESE GUIDELINES:

- Build a braced end wall at the end of the bay, or permanently install the first eight feet of AJS® Joist and the first course of sheathing. As an alternate, temporary sheathing may be nailed to the first four feet of AJS® Joist at the end of the bay.
- All hangers, AJS® rim joists, rim boards, AJS® blocking panels, and x-bracing must be completely installed and properly nailed as each AJS® Joist is set.
- Install temporary 1x4 strut lines at no more than eight feet on center as additional AJS® Joists are set. Nail the strut lines to the sheathed area, or braced end wall, and to each AJS® Joist with two 8d nails.
- The ends of cantilevers must be temporarily secured by strut lines on both the top and bottom flanges.
- Straighten the AJS® Joist to within 1/2 inch of true alignment before attaching strut lines and sheathing.
- Remove the temporary strut lines only as required to install the permanent sheathing.
- Failure to install temporary bracing may result in sideways buckling or roll-over under light construction loads.
- Do not stack construction materials (sheathing, drywall, etc) in the middle of AJS® Joist spans, contact Boise EWP Engineering for proper storage and shoring information.



Additional floor framing details available with BC FRAMER® software (see page 31)

END BEARING DETAILS

F07

Nail Boise Rimboard to AJS® Joists with 8d nail into each flange. Dimension lumber is not suitable for use as rim board with AJS® Joists.

F07A

Dimension lumber is not suitable for use as rim board with AJS® Joists.

F02

AJS® rim joist. AJS® 25 requires 2x6 wall for minimum bearing.

F01

AJS® blocking.

F27A

Top Flange or Face Mount Joist Hanger. VERSA-LAM®.

F52

One 8d nail each side at bearing. 1 1/2" minimum bearing length. To limit splitting flange, start nails at least 1 1/2" from end. Nails may need to be driven at an angle to limit splitting of bearing plate.

F08

Solid block all posts from above to bearing below.

F03

AJS® rim joist. AJS® 25 requires 2x6 wall for minimum bearing. Note: AJS® floor joist must be designed to carry wall above when not stacked over wall below.

INTERMEDIATE BEARING DETAILS

F06

For load bearing wall above (stacked over wall below).

AJS® Joist blocking.

Blocking may be required, consult design professional of record and/or local building official.

F09

Load bearing wall above (stacked over wall below). 2x block. Nail block with one 10d nail into each flange.

Size	Joist Spacing [in]			
	12	16	19.2	24
2x4	4463	3347	2789	2231
2x6	7013	5259	4383	3506

1. Squash blocks are to be in full contact with upper floor and lower wall plate.
2. Capacities shown are for a double squash blocks at each joist, SPF or better.

AJS® Joist Slope Cut Reinforcement

Detail below restores original allowable shear/reaction value to cut end of AJS® joist. AJS® Joist shall not be used as a collar or rafter tension tie.

2 x 6 min. rafter. Rafter shall be supported by ridge beam or other upper bearing support.

6 min, 12 min, 16 max. AJS® depth, 24".

F10

Backer block (minimum 12" wide). Nail with 10-10d nails. Joist Hanger. Filler block. Nail with 10-10d nails. Backer block required where top flange joist hanger load exceeds 250 lbs. Install tight to top flange.

F58

Double AJS® Joist Connection

Filler Block (see chart below). Web-Filler Nailing 12" on-center. Connection valid for all applications. Contact Boise EWP Engineering for specific conditions.

F05

Sheathing or rimboard closure. AJS® blocking required for cantilever. For load bearing cantilever, see pages 8 and 9. Uplift on backspan shall be considered in all cantilever designs.

LATERAL SUPPORT

- AJS® Joists must be laterally supported at the ends with hangers, AJS® rim joists, rim boards, AJS® blocking panels or x-bracing. AJS® blocking panels or x-bracing are required at cantilever supports.
- Blocking may be required at intermediate bearings for floor diaphragm per IRC in high seismic areas, consult local building official.

MINIMUM BEARING LENGTH FOR AJS® JOISTS

- 1 1/2 inches is required at end supports. 3 1/2 inches is required at cantilever and intermediate supports.
- Longer bearing lengths allow higher reaction values. Refer to the building code evaluation report or the BC CALC® software.

NAILING REQUIREMENTS

- AJS® rim joist, rim board or closure panel to AJS® Joist:
 - Rims or closure panel 1 1/4 inches thick and less: 2-8d nails, one each in the top and bottom flange.
 - AJS® 140/20 rim joist: 2-16d box nails, one each in the top and bottom flange.
 - AJS® 25 rim joist: Toe-nail top flange to rim joist with 2-10d box nails, one each side of flange.
- AJS® rim joist, rim board or AJS® blocking panel to support:
 - 8d nails at 6 inches on center.
 - When used for shear transfer, follow the building designer's specification.

- AJS® Joist to support:
 - 2-8d nails, one on each side of the web, placed 1 1/2 inches minimum from the end of the AJS® Joist to limit splitting.
- Sheathing to AJS® Joist:
 - Prescriptive residential floor sheathing nailing requires 8d common nails @ 6" o.c. on edges and @ 12" o.c. in the field IRC Table R602.3(1).
 - Maximum nail spacing for minimum lateral stability = 24".
 - 14 gauge staples may be substituted for 8d nails if the staples penetrate at least 1 inch into the joist.
 - Wood screws may be acceptable, contact local building official and/or Boise EWP Engineering for further information.

BACKER AND FILLER BLOCK DIMENSIONS

Series	Backer Block Thickness	Filler Block Thickness
AJS® 140	1 1/8" or two 1/2" wood panels	2 x ___ + 5/8" wood panel
AJS® 20	1 1/8" or two 1/2" wood panels	2 x ___ + 5/8" wood panel
AJS® 25	2 x ___ lumber	Double 2 x ___ lumber

- Cut backer and filler blocks to a maximum depth equal to the web depth minus 1/4" to avoid a forced fit.
- For deeper AJS® 25 Joists, stack 2x lumber or use multiple pieces of 3/4" wood panels.

WEB STIFFENER REQUIREMENTS

- See *Web Stiffener Requirements* on page 10.

PROTECT AJS® JOISTS FROM THE WEATHER

- AJS® Joists is intended only for applications that provide permanent protection from the weather. Bundles of product should be covered and stored off of the ground on stickers.

AJS® RIM JOISTS AND BLOCKING

Joist Depth	Vertical Load Transfer Capacity (plf)
9 1/2"	1875
11 1/8"	1680
14"	1500
16"	1340
18" - 20"	3200 ⁽¹⁾
22" - 24"	2700 ⁽¹⁾

1) Web stiffeners required at each end of blocking panel. Distance between stiffeners must be less than 24".

AJS® Joists are manufactured with 1½" round perforated knockouts in the web at approximately 12" on center

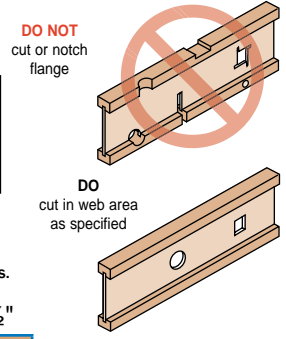
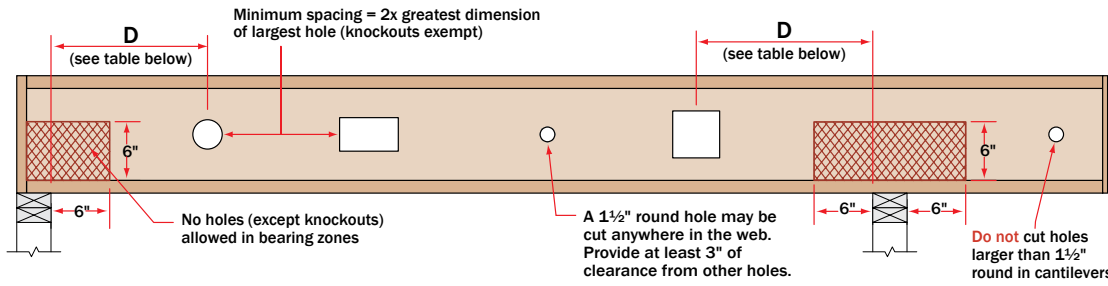

Minimum distance from support, listed in table below, is required for all holes greater than 1½"

MINIMUM DISTANCE (D) FROM ANY SUPPORT TO THE CENTERLINE OF THE HOLE																
Round Hole Diameter [in]		2	3	4	5	6	6½	7	8	8⅞	9	10	11	12	13	
Rectangular Hole Side [in]		-	-	2	4	6	6	-	-	-	-	-	-	-	-	
Any 9½" Joist	Span [ft]	8	2'-3"	2'-8"	3'-1"	3'-6"	4'-0"	4'-0"								
		12	3'-5"	4'-0"	4'-8"	5'-4"	6'-0"	6'-0"								
	Span [ft]	16	4'-6"	5'-5"	6'-3"	7'-1"	8'-0"	8'-0"								
		20	5'-7"	6'-8"	7'-9"	8'-10"	9'-11"	10'-0"								
Any 11⅞" Joist	Span [ft]	8	1'-7"	1'-11"	2'-4"	2'-8"	3'-0"	3'-3"	3'-5"	3'-9"	4'-0"					
		12	2'-5"	2'-11"	3'-6"	4'-0"	4'-7"	4'-10"	5'-1"	5'-8"	6'-0"					
	Span [ft]	16	3'-2"	3'-11"	4'-8"	5'-4"	6'-1"	6'-6"	6'-10"	7'-7"	8'-0"					
		20	4'-0"	4'-11"	5'-10"	6'-9"	7'-8"	8'-1"	8'-6"	9'-5"	10'-0"					
Any 14" Joist	Span [ft]	8	1'-1"	1'-5"	1'-9"	2'-1"	2'-5"	2'-7"	2'-8"	3'-0"	3'-4"	3'-4"	3'-8"	4'-0"		
		12	1'-8"	2'-2"	2'-8"	3'-1"	3'-7"	3'-10"	4'-1"	4'-7"	5'-0"	5'-0"	5'-6"	6'-0"		
	Span [ft]	16	2'-3"	2'-11"	3'-6"	4'-2"	4'-10"	5'-2"	5'-5"	6'-1"	6'-8"	6'-9"	7'-4"	8'-0"		
		20	2'-10"	3'-7"	4'-5"	5'-3"	6'-0"	6'-5"	6'-10"	7'-7"	8'-4"	8'-5"	9'-3"	10'-0"		
Any 16" Joist	Span [ft]	8	1'-0"	1'-1"	1'-4"	1'-7"	1'-11"	2'-1"	2'-2"	2'-6"	2'-9"	2'-9"	3'-1"	3'-4"	3'-8"	3'-11"
		12	1'-2"	1'-7"	2'-0"	2'-5"	2'-11"	3'-1"	3'-4"	3'-9"	4'-1"	4'-2"	4'-7"	5'-1"	5'-6"	5'-11"
	Span [ft]	16	1'-7"	2'-1"	2'-8"	3'-3"	3'-10"	4'-2"	4'-5"	5'-0"	5'-6"	5'-7"	6'-2"	6'-9"	7'-4"	7'-11"
		20	1'-11"	2'-8"	3'-5"	4'-1"	4'-10"	5'-2"	5'-7"	6'-3"	6'-11"	7'-0"	7'-9"	8'-5"	9'-2"	9'-11"
Any 18" AJS® 25	Span [ft]	8	1'-0"	1'-1"	1'-4"	1'-7"	1'-11"	2'-1"	2'-2"	2'-6"	2'-9"	2'-9"	3'-1"	3'-4"	3'-8"	3'-11"
		12	1'-0"	1'-1"	1'-2"	1'-5"	2'-0"	2'-3"	2'-6"	3'-0"	3'-6"	3'-7"	4'-1"	4'-8"	5'-2"	5'-9"
	Span [ft]	16	1'-0"	1'-1"	1'-3"	1'-11"	2'-8"	3'-0"	3'-4"	4'-1"	4'-8"	4'-9"	5'-6"	6'-3"	6'-11"	7'-8"
		20	1'-0"	1'-1"	1'-6"	2'-5"	3'-4"	3'-9"	4'-2"	5'-1"	5'-10"	6'-0"	6'-11"	7'-9"	8'-8"	9'-7"
Any 20" AJS® 25	Span [ft]	8	1'-0"	1'-1"	1'-10"	2'-11"	4'-0"	4'-6"	5'-1"	6'-1"	7'-1"	7'-2"	8'-3"	9'-4"	10'-5"	11'-6"
		12	1'-0"	1'-1"	1'-2"	1'-2"	1'-7"	1'-10"	2'-1"	2'-7"	3'-0"	3'-0"	3'-6"	4'-0"	4'-5"	4'-11"
	Span [ft]	16	1'-0"	1'-1"	1'-2"	1'-7"	2'-2"	2'-6"	2'-10"	3'-5"	4'-0"	4'-1"	4'-8"	5'-4"	5'-11"	6'-7"
		20	1'-0"	1'-1"	1'-2"	1'-11"	2'-9"	3'-1"	3'-6"	4'-4"	5'-0"	5'-1"	5'-10"	6'-8"	7'-5"	8'-3"
Any 22" AJS® 25	Span [ft]	8	1'-0"	1'-1"	1'-5"	2'-4"	3'-3"	3'-9"	4'-3"	5'-2"	6'-0"	6'-1"	7'-1"	8'-0"	8'-11"	9'-10"
		12	1'-0"	1'-1"	1'-2"	1'-2"	1'-7"	1'-10"	2'-1"	2'-7"	3'-0"	3'-0"	3'-6"	4'-0"	4'-5"	4'-11"
	Span [ft]	16	1'-0"	1'-1"	1'-2"	1'-7"	2'-2"	2'-6"	2'-10"	3'-5"	4'-0"	4'-1"	4'-8"	5'-4"	5'-11"	6'-7"
		20	1'-0"	1'-1"	1'-2"	1'-11"	2'-9"	3'-1"	3'-6"	4'-4"	5'-0"	5'-1"	5'-10"	6'-8"	7'-5"	8'-3"
Any 24" AJS® 25	Span [ft]	8	1'-0"	1'-1"	1'-2"	1'-2"	1'-3"	1'-3"	1'-3"	1'-7"	1'-11"	2'-0"	2'-4"	2'-8"	3'-1"	3'-5"
		12	1'-0"	1'-1"	1'-2"	1'-2"	1'-3"	1'-6"	1'-9"	2'-3"	2'-8"	2'-9"	3'-3"	3'-9"	4'-4"	4'-10"
	Span [ft]	14	1'-0"	1'-1"	1'-2"	1'-2"	1'-3"	1'-3"	1'-3"	1'-7"	2'-0"	2'-1"	2'-7"	3'-0"	3'-6"	4'-0"
		18	1'-0"	1'-1"	1'-2"	1'-2"	1'-3"	1'-3"	1'-5"	2'-1"	2'-7"	2'-8"	3'-3"	3'-11"	4'-6"	5'-2"

- Select a table row based on joist depth and the actual joist span rounded up to the nearest table span. Scan across the row to the column headed by the appropriate round hole diameter or rectangular hole side. Use the longest side of a rectangular hole. The table value is the closest that the centerline of the hole may be to the centerline of the nearest support.
- The entire web may be cut out. **DO NOT** cut the flanges. Holes apply to either single or multiple joists in repetitive member conditions.
- For multiple holes, the amount of uncut web between holes must equal at least twice the diameter (or longest side) of the largest hole.
- 1½" round knockouts in the web may be removed by using a short piece of metal pipe and hammer.
- Holes may be positioned vertically anywhere in the web. The joist may be set with the 1½" knockout holes turned either up or down.
- This table was designed to apply to the design conditions covered by tables elsewhere in this publication. Use the BC CALC® software to check other hole sizes or holes under other design conditions. It may be possible to exceed the limitations of this table by analyzing a specific application with the BC CALC® software.

AJS® Joists

Joist Depth [in]	Joist Series	Roof Truss Span [ft]	Roof Total Load [psf]									
			35			45			55			
			Joist Spacing [in]									
			16	19.2	24	16	19.2	24	16	19.2	24	
9 1/2"	AJS® 140	24	0	0	1	0	0	X	0	X	X	
		26	0	0	1	0	1	X	1	X	X	
		28	0	0	X	0	1	X	1	X	X	
		30	0	0	X	0	X	X	X	X	X	
		32	0	0	X	1	X	X	X	X	X	
		34	0	1	X	1	X	X	X	X	X	
		36	0	1	X	1	X	X	X	X	X	
		38	0	X	X	X	X	X	X	X	X	
	40	0	X	X	X	X	X	X	X	X		
	AJS® 20	24	0	0	1	0	0	2	0	2	X	
		26	0	0	1	0	1	X	1	2	X	
		28	0	0	1	0	1	X	1	2	X	
30		0	0	2	0	2	X	1	X	X		
32		0	0	2	1	2	X	2	X	X		
34		0	1	2	1	2	X	2	X	X		
36		0	1	X	1	X	X	2	X	X		
38		0	1	X	1	X	X	X	X	X		
AJS® 25	24	0	0	1	0	0	X	0	2	X		
	26	0	0	1	0	1	X	1	X	X		
	28	0	0	2	0	1	X	1	X	X		
	30	0	0	2	0	2	X	2	X	X		
	32	0	0	X	1	2	X	2	X	X		
	34	0	1	X	1	X	X	X	X	X		
	36	0	1	X	1	X	X	X	X	X		
	38	0	2	X	2	X	X	X	X	X		
11 7/8"	AJS® 140	24	0	0	0	0	0	0	0	X		
		26	0	0	0	0	0	1	0	0	X	
		28	0	0	0	0	0	1	0	1	X	
		30	0	0	0	0	0	X	0	1	X	
		32	0	0	0	0	0	X	0	1	X	
		34	0	0	1	0	0	X	0	X	X	
		36	0	0	1	0	1	X	1	X	X	
		38	0	0	1	0	1	X	1	X	X	
	40	0	0	X	0	1	X	1	X	X		
	AJS® 20	24	0	0	0	0	0	WS	0	0	1	
		26	0	0	0	0	0	1	0	0	2	
		28	0	0	0	0	0	1	0	1	X	
30		0	0	0	0	0	1	0	1	X		
32		0	0	WS	0	0	2	0	1	X		
34		0	0	1	0	0	X	0	1	X		
36		0	0	1	0	1	X	1	2	X		
38		0	0	1	0	1	X	1	2	X		
40	0	0	1	0	1	X	1	X	X			
AJS® 25	24	0	0	0	0	0	0	0	0	2		
	26	0	0	0	0	0	1	0	0	2		
	28	0	0	0	0	0	1	0	1	2		
	30	0	0	0	0	0	1	0	1	X		
	32	0	0	0	0	0	2	0	1	X		
	34	0	0	1	0	0	2	0	2	X		
	36	0	0	1	0	1	X	1	2	X		
	38	0	0	1	0	1	X	1	X	X		
40	0	0	2	0	1	X	1	X	X			

Joist Depth [in]	Joist Series	Roof Truss Span [ft]	Roof Total Load [psf]									
			35			45			55			
			Joist Spacing [in]									
			16	19.2	24	16	19.2	24	16	19.2	24	
14"	AJS® 20	24	0	0	0	0	0	WS	0	0	WS	
		26	0	0	0	0	0	WS	0	0	WS	
		28	0	0	0	0	0	WS	0	0	1	
		30	0	0	0	0	0	WS	0	WS	1	
		32	0	0	WS	0	0	WS	0	WS	X	
		34	0	0	WS	0	0	1	0	WS	X	
		36	0	0	WS	0	WS	1	0	1	X	
		38	0	0	WS	0	WS	1	0	1	X	
	AJS® 25	24	0	0	WS	0	WS	X	WS	1	X	
		26	0	0	0	0	0	0	0	0	WS	
		28	0	0	0	0	0	0	0	0	1	
		30	0	0	0	0	0	WS	0	0	1	
32		0	0	0	0	0	WS	0	0	2		
34		0	0	0	0	0	1	0	WS	2		
36		0	0	0	0	0	1	0	1	2		
38		0	0	WS	0	0	1	0	1	X		
16"	AJS® 20	24	0	0	0	0	0	WS	0	0	WS	
		26	0	0	0	0	0	WS	0	0	WS	
		28	0	0	0	0	0	WS	0	WS	WS	
		30	0	0	0	0	0	WS	0	WS	WS	
		32	0	0	WS	0	0	WS	0	WS	1	
		34	0	0	WS	0	0	WS	0	WS	1	
		36	0	0	WS	0	WS	WS	0	WS	1	
		38	0	0	WS	0	WS	WS	WS	WS	X	
	AJS® 25	24	0	0	WS	0	WS	1	WS	WS	X	
		26	0	0	0	0	0	0	0	0	WS	
		28	0	0	0	0	0	0	0	0	WS	
		30	0	0	0	0	0	WS	0	0	WS	
32		0	0	0	0	0	WS	0	0	1		
34		0	0	0	0	0	WS	0	WS	1		
36		0	0	0	0	0	WS	0	WS	1		
38		0	0	0	0	0	WS	0	WS	1		

KEY TO TABLE

- 0 No Reinforcement Required
- WS Web Stiffeners at Support
- 1 Web Stiffeners Plus One Reinforcer
- 2 Web Stiffeners Plus Two Reinforcers
- X Use Deeper Joists or Closer Spacing

1. Cut 48" long reinforcers to match the joist depth. Use 23/32" APA Rated Sheathing, Exposure 1, 48/24 Span Rating panels. The face grain must be horizontal (measure the 48" dimension along the long edge of the panel).
2. Fasten the reinforcer to the joist flanges with 8d nails at 6" o. c. When reinforcing both sides, stagger the nails to avoid splitting the joist flanges.
3. Attach web stiffeners per intermediate Web Stiffener Nailing Schedule on page 10.
4. Use the BC CALC® software to analyze conditions that are not covered by this table.

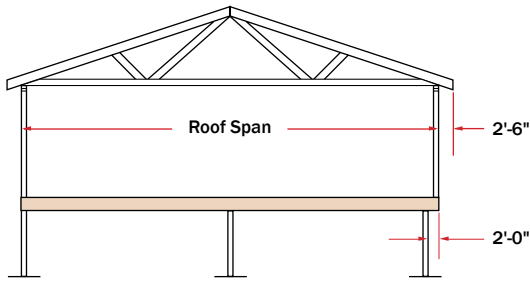

The tables and details on pages 8 and 9 indicate the type of reinforcements, if any, that are required for load-bearing cantilevers up to a maximum length of 2'-0". Cantilevers longer than 2'-0" cannot be reinforced. **However, longer cantilevers with lower loads may be allowable without reinforcement. Analyze specific applications with the BC CALC® software.**

PLYWOOD / OSB REINFORCEMENT (If Required per Table on page 8)

- ²³/₃₂" Min. x 48" long plywood / OSB rated sheathing must match the full depth of the AJS® Joist. Nail to the AJS® Joist with 8d nails at 6" o.c. and nail with 4-8d nails into backer block. When reinforcing both sides, stagger nails to limit splitting. Install with horizontal face grain.
- These requirements assume a 100 PLF wall load and apply to AJS® Joists. Additional support may be required for other loadings. See BC CALC® software.
- Contact Boise EWP Engineering for reinforcement requirements on AJS® Joist depths greater than 16".

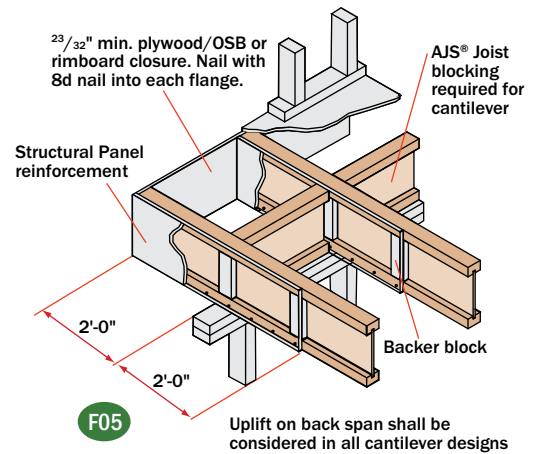

Brick Ledge Load Bearing Cantilever

F20A Brick Ledge With Blocking Panels

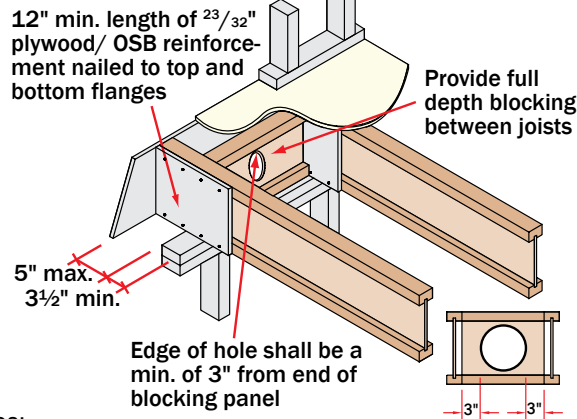

Notes:

1. Use ²³/₃₂" min plywood/OSB rated sheathing. Install full depth of joist with face grain parallel to joist. Plywood reinforcement to bear fully on wall plate. Nail plywood to top and bottom joist flanges with 2½" (8d) nails at 3" on center except 9½" joists, install nails at 2½" on center.
2. Provide full depth blocking between joists.
3. Edge of hole shall be at a minimum of 3" from end of blocking panel.

F20B Brick Ledge Without Blocking Panels

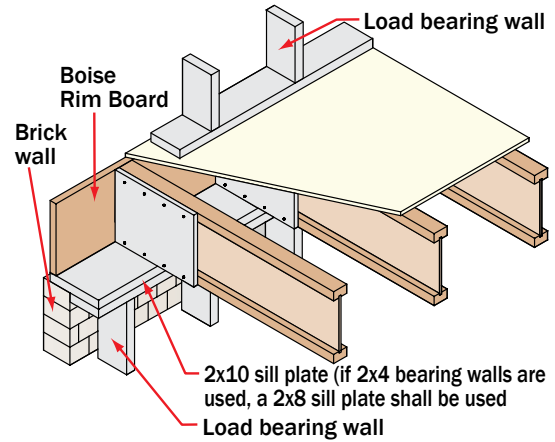

Notes:

1. Use ²³/₃₂" min plywood/OSB rated sheathing. Install full depth of joist with face grain parallel to joist. Plywood reinforcement to bear fully on wall plate. Nail plywood to top and bottom joist flanges with 2½" (8d) nails at 3" on center except 9½" joists, install nails at 2½" on center.
2. Minimum bearing length 3½".
3. Sill plate shall be properly nailed to wall.
4. See page 6 for joist and rimboard connection details.

Joist Depth (inches)	Roof Truss Span (ft)	Roof Live Load (psf)											
		20 psf			30 psf			40 psf			50 psf		
		Joist Spacing o.c.											
		12"	16"	19.2"	12"	16"	19.2"	12"	16"	19.2"	12"	16"	19.2"
9½"	24'	0	0	0	0	0	1	0	1	1	0	1	1
	26'	0	0	0	0	0	1	0	1	1	0	1	2
	28'	0	0	0	0	0	1	0	1	1	0	1	2
	30'	0	0	0	0	0	1	0	1	1	1	1	2
	32'	0	0	1	0	1	1	0	1	2	1	2	2
	34'	0	0	X	0	X	X	0	1	X	1	2	X
11⅞"	24'	0	X	X	0	X	X	1	X	X	1	X	X
	26'	0	0	0	0	0	0	0	0	0	0	0	1
	28'	0	0	0	0	0	0	0	0	1	0	1	1
	30'	0	0	0	0	0	0	0	0	1	0	1	1
	32'	0	0	0	0	0	0	0	0	1	0	1	1
	34'	0	0	0	0	0	1	1	0	1	1	0	1
14"	24'	0	0	0	0	1	1	0	1	1	0	1	X
	26'	0	0	0	0	0	0	0	0	0	0	0	0
	28'	0	0	0	0	0	0	0	0	0	0	0	1
	30'	0	0	0	0	0	0	0	0	0	0	0	1
	32'	0	0	0	0	0	0	0	0	0	0	0	1
	34'	0	0	0	0	0	0	0	0	0	1	0	1
36'	0	0	0	0	0	0	0	0	1	0	1	X	

Reinforcement Requirements (Brick Ledge)

Table assumes a 40 psf live load and a 15 psf dead load on the floors, an 80 plf wall load, and a 15 psf dead load on the roof.

Reinforcement Legend:

- 0 = No reinforcement required.
- 1 = Reinforcement required on one side of joist.
- 2 = Reinforcement required on both sides of joist.
- X = Reinforcement will not work. Reduce spacing of joist and recheck.

Non-Load Bearing Wall Cantilever Details

AJS® Joists are intended only for applications that provide permanent protection from the weather.

Fasten the 2x8 minimum to the AJS® Joist by nailing through the backer block and joist web with 2 rows of 10d nails at 6" on center. Clinch all nails.

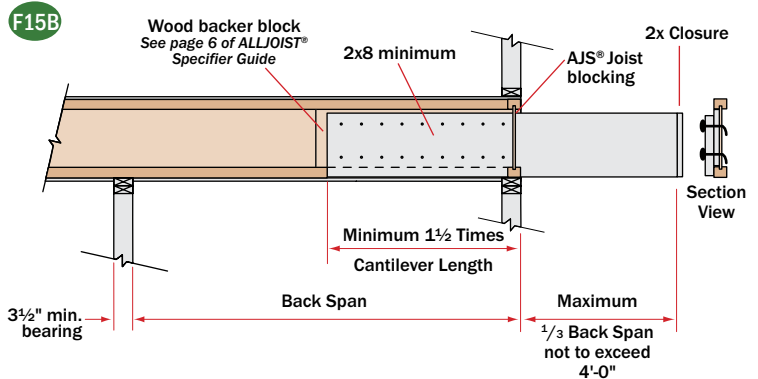
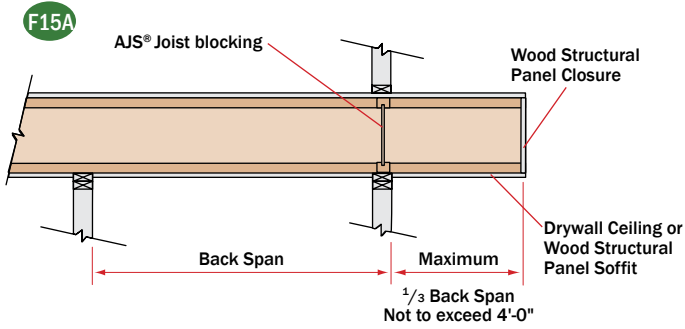

- These details apply to cantilevers with uniform loads only.
- It may be possible to exceed the limitations of these details by analyzing a specific application with the BC CALC® software.

Web Stiffener Requirements

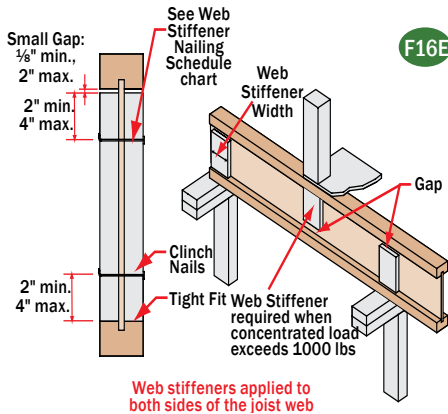

Web Stiffener Nailing Schedule		
ALLJOIST® Series	Joist Depth	Nailing
AJS® 140 / 20 / 25	9½" – 11⅝"	3-10d
	14" – 24"	5-10d

NOTES

- Web stiffeners are optional except as noted below.
- Web stiffeners are always required for 18" and deeper AJS® joists at all bearing locations.
- Web stiffeners are always required in hangers that do not extend up to support the top flange of the AJS® Joist. Web stiffeners may be required with certain sloped or skewed hangers or to achieve uplift values. Refer to the hanger manufacturer's installation requirements.
- Web stiffeners are always required in certain roof applications. See *Roof Framing Details* on page 14.
- Web stiffeners are always required under concentrated loads that exceed 1000 pounds. Install the web stiffeners snug to the top flange in this situation. Follow the nailing schedule for intermediate bearings.
- Web stiffeners may be used to increase allowable reaction values. See *AJS® Design Properties* on page 21 of the ASG or the BC CALC® software.

Structural Panel Web Stiffener			
Series	Minimum Thickness		Minimum Width
	In Hanger	No Hanger	
AJS® 140/20	1"	1½"	2 ⁵ / ₁₆ "
AJS® 25	2x4 lumber (vertical)		

Large Rectangular Holes in AJS® Joists

Hole size table based on maximum uniform load of 40 psf live load and 15 psf dead load, at maximum spacing of 24" on-center.

Single Span Joist

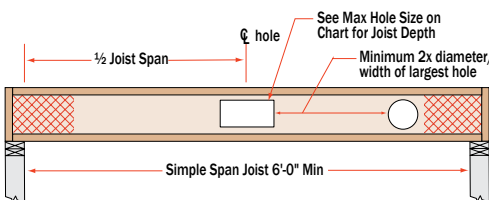

Joist Depth	Maximum Hole Size	
	Simple Span	Multiple Span
9½"	6" x 12"	6" x 7"
11⅝"	8" x 13"	8" x 8"
14"	9" x 16"	8" x 13"
	10" x 14"	9" x 11"
16"	11" x 16"	10" x 14"
	12" x 15"	11" x 12"

Multiple Span Joist

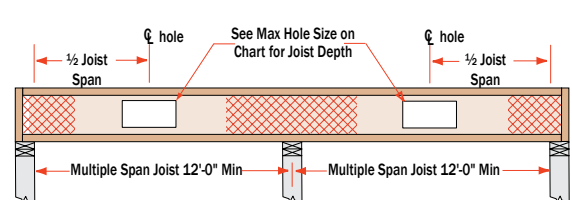

Notes:

Additional holes may be cut in the web provided they meet the specifications as shown in the hole distance chart shown above or as allowed using BC CALC® sizing software.

Notes:

Larger holes may be possible for either Single or Multiple span joists; use BC CALC® sizing software for specific analysis.

Allowable Uniform Floor Load (in pounds per linear foot [PLF])

100% Load Duration

Span Length	AJS® 140 Series 2½" Flange Width				AJS® 20 Series 2½" Flange Width							
	9½" AJS® 140		11⅞" AJS® 140		9½" AJS® 20		11⅞" AJS® 20		14" AJS® 20		16" AJS® 20	
	Live Load	Total Load	Live Load	Total Load	Live Load	Total Load	Live Load	Total Load	Live Load	Total Load	Live Load	Total Load
6	-	313	-	318	-	313	-	318	-	320	-	323
7	-	268	-	272	-	268	-	272	-	274	-	277
8	-	235	-	238	-	235	-	238	-	240	-	242
9	-	208	-	212	-	208	-	212	-	213	-	215
10	170	188	-	191	-	188	-	191	-	192	-	194
11	131	161	-	173	161	170	-	173	-	174	-	176
12	103	136	-	159	128	156	-	159	-	160	-	161
13	82	115	136	146	102	144	-	146	-	147	-	149
14	67	100	111	129	83	134	-	136	-	137	-	138
15	55	87	91	112	69	120	113	127	-	128	-	129
16	46	76	76	99	57	106	95	119	-	120	-	121
17			64	87	48	93	80	112	-	112	-	114
18			54	78	41	82	68	106	98	106	-	107
19			46	70			58	97	84	101	-	102
20			40	63			50	88	73	96	-	97
21							44	79	63	91	85	92
22									55	87	74	88
23									49	80	65	84
24									43	73	58	80
25											52	77
26											46	72
27											41	67
28												
29												
30												

- Total Load values are limited by shear, moment, or deflection equal to L/240.
- Live Load values are limited by deflection equal to L/480. For deflection limits of L/360 and L/960, multiply the Live Load values by 1.33 and 0.50 respectively.
- Both the Total Load and Live Load columns must be checked. Where a Live Load value is not shown, the Total Load value will control.
- Table values apply to either simple or multiple span joists. Span is measured center to center of the minimum required bearing length. Analyze multiple span joists with the BC CALC® software if the length of any span is less than half the length of an adjacent span.
- Table values do not consider composite action from gluing and nailing floor sheathing (composite action is considered in floor span tables on page 4).
- Total Load values assume minimum bearing lengths without web stiffeners for joist depths of 16 inches and less.
- For assistance with floor design, consult the section *About Floor Performance* on page 4.
- This table was designed to apply to a broad range of applications. It may be possible to exceed the limitations of this table by analyzing a specific application with the BC CALC® software.

Allowable Uniform Floor Load (in pounds per linear foot [PLF])

100% Load Duration

Span Length	AJS® 25 Series 3½" Flange Width															
	9½" AJS® 25		11⅞" AJS® 25		14" AJS® 25		16" AJS® 25		18" AJS® 25		20" AJS® 25		22" AJS® 25		24" AJS® 25	
	Live Load	Total Load	Live Load	Total Load	Live Load	Total Load	Live Load	Total Load	Live Load	Total Load	Live Load	Total Load	Live Load	Total Load	Live Load	Total Load
6	-	316	-	318	-	320	-	323	-	629	-	681	-	697	-	712
7	-	271	-	272	-	274	-	277	-	539	-	584	-	597	-	610
8	-	237	-	238	-	240	-	242	-	472	-	511	-	523	-	534
9	-	211	-	212	-	213	-	215	-	419	-	454	-	464	-	475
10	-	190	-	191	-	192	-	194	-	377	-	408	-	418	-	427
11	-	172	-	173	-	174	-	176	-	343	-	371	-	380	-	388
12	-	158	-	159	-	160	-	161	-	314	-	340	-	348	-	356
13	131	146	-	146	-	147	-	149	-	290	-	314	-	321	-	328
14	107	135	-	136	-	137	-	138	-	269	-	292	-	298	-	305
15	88	126	-	127	-	128	-	129	-	251	-	272	-	278	-	285
16	74	118	-	119	-	120	-	121	-	236	-	255	-	261	-	267
17	62	111	102	112	-	112	-	114	-	222	-	240	-	246	-	251
18	53	105	87	106	-	106	-	107	-	209	-	227	-	232	-	237
19	45	91	75	100	-	101	-	102	197	198	-	215	-	220	-	225
20			65	95	93	96	-	97	171	188	-	204	-	209	-	213
21			56	90	81	91	-	92	150	179	187	194	-	199	-	203
22			49	86	71	87	-	88	132	171	165	185	-	190	-	194
23			43	83	62	83	84	84	116	164	146	177	178	181	-	185
24					55	80	74	80	103	152	129	170	158	174	-	178
25					49	76	66	77	92	140	115	157	141	167	170	171
26					44	73	59	74	82	129	103	145	127	159	153	164
27							53	71	74	120	93	134	114	147	137	158
28							48	69	66	111	84	125	103	137	124	149
29							43	66	60	104	76	116	93	127	112	139
30									54	97	69	109	84	119	102	130



AJS® Rafters

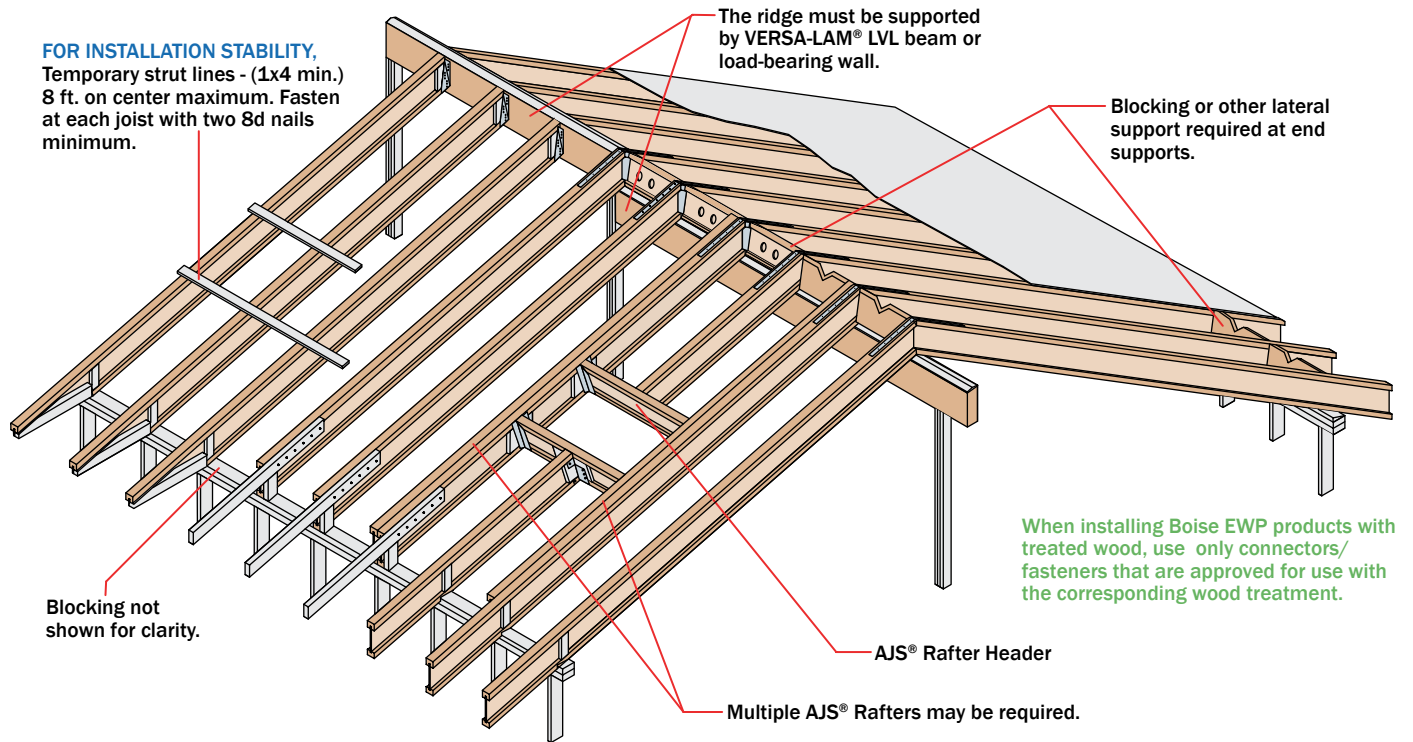

SAFETY WARNING

DO NOT ALLOW WORKERS ON AJS® JOISTS UNTIL ALL HANGERS, AJS® RIM JOISTS, RIM BOARDS, AJS® BLOCKING PANELS, X-BRACING AND TEMPORARY 1x4 STRUT LINES ARE INSTALLED AS SPECIFIED BELOW.

SERIOUS ACCIDENTS CAN RESULT FROM INSUFFICIENT ATTENTION TO PROPER BRACING DURING CONSTRUCTION. ACCIDENTS CAN BE AVOIDED UNDER NORMAL CONDITIONS BY FOLLOWING THESE GUIDELINES:

- Build a braced end wall at the end of the bay, or permanently install the first eight feet of AJS® Joists and the first course of sheathing. As an alternate, temporary sheathing may be nailed to the first four feet of AJS® Joists at the end of the bay.
- All hangers, AJS® rim joists, rim boards, AJS® blocking panels, and x-bracing must be completely installed and properly nailed as each AJS® Joist is set.
- Install temporary 1x4 strut lines at no more than eight feet on center as additional AJS® Joists are set. Nail the strut lines to the sheathed area, or braced end wall, and to each AJS® Joist with two 8d nails.
- The ends of cantilevers must be temporarily secured by strut lines on both the top and bottom flanges.
- Straighten the AJS® Joist to within 1/2 inch of true alignment before attaching strut lines and sheathing.
- Remove the temporary strut lines only as required to install the permanent sheathing.
- Failure to install temporary bracing may result in sideways buckling or roll-over under light construction loads.

AJS® Ceiling Joist with Bevel End Cut (For Limited-Access Attics Only)

AJS® Joist shall not be used as collar/tension tie. Roof rafter shall be supported by ridge beam or other upper bearing support.

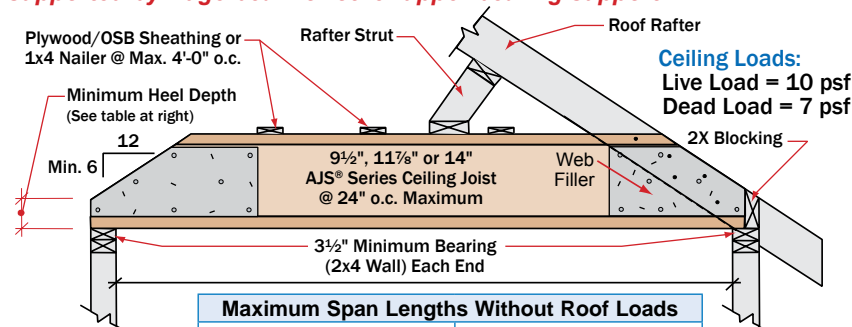

Maximum Span Lengths Without Roof Loads		
9 1/2" AJS® 140, 20, 25		20'-0"
11 1/8" AJS® 140, 20, 25		22'-6"
14" AJS® 140, 20, 25		25'-0"

(If roof loads present, see Notes 2 & 3 at right)

Minimum Heel Depths	Joist Depth	End Wall	
		2 x 4	2 x 6
9 1/2"	9 1/2"	2 1/2"	1 1/2"
11 1/8"	11 1/8"	3 1/2"	2 1/2"
14"	14"	4 1/2"	3 1/2"

Notes:

- 1) Detail is to be used only for ceiling joists with no access to attic space.
- 2) Ceiling joist must be designed to carry all roof load transferred through rafter struts as shown.
- 3) AJS® ceiling joist end reaction may not exceed 550 pounds.
- 4) Minimum roof slope is 6/12.
- 5) Nail roof rafter to AJS® top flange with 1-16d sinker or box nail.
- 6) 1x4 nailers must be continuous and nailed to a braced end wall.
- 7) Install a web stiffener on each side of AJS® Joist at beveled ends. Nail roof rafter to AJS® Joist per building code requirements for ceiling joist to roof rafter connection.

Additional roof framing details available with BC FRAMER® software (see page 31)

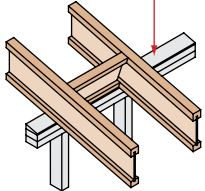
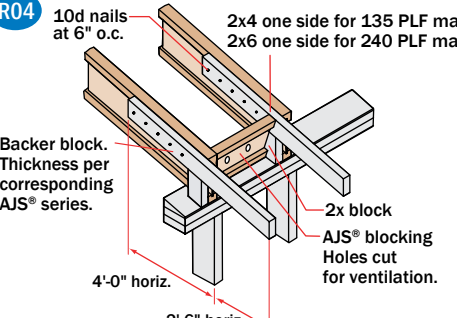
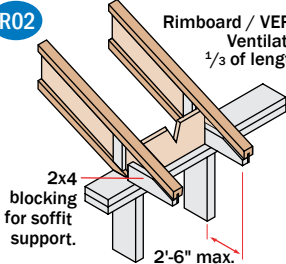
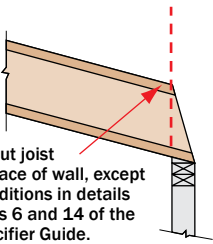
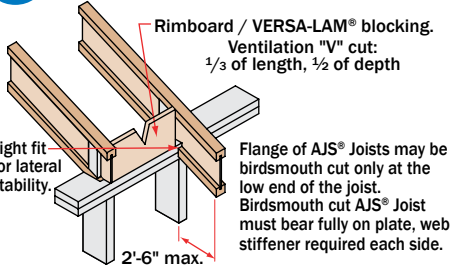
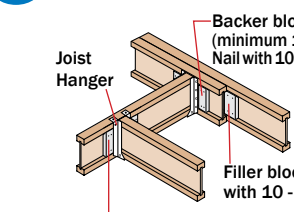
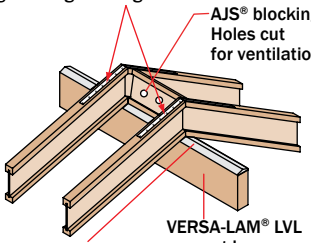
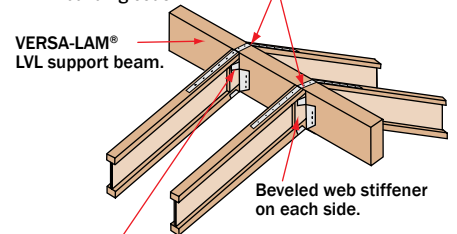
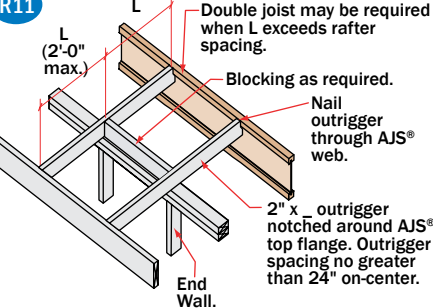
<p>R01</p> <p>2x beveled plate for slope greater than $\frac{1}{4}/12$.</p>  <p>Simpson VPA or USP TMP connectors or equal can be used in lieu of beveled plate for slopes from 3/12 to 12/12.</p>	<p>R04</p> <p>10d nails at 6" o.c.</p> <p>2x4 one side for 135 PLF max. 2x6 one side for 240 PLF max.</p> <p>Backer block. Thickness per corresponding AJS® series.</p> <p>2x block</p> <p>AJS® blocking Holes cut for ventilation.</p> <p>4'-0" horiz.</p> <p>2'-6" horiz.</p> 	<p>R02</p> <p>Rimboard / VERSA-LAM® blocking. Ventilation "V" cut: $\frac{1}{3}$ of length, $\frac{1}{2}$ of depth</p> <p>2x4 blocking for soffit support.</p> <p>2'-6" max.</p> <p>Flange of AJS® Joists may be birdsmouth cut only at the low end of the joist. Birds-mouth cut AJS® joist must bear fully on plate, web stiffener required each side. Bottom flange shall be fully supported.</p> 
<p>DN05</p>  <p>DO NOT bevel-cut joist beyond inside face of wall, except for specific conditions in details shown on pages 6 and 14 of the ALLJOIST® Specifier Guide.</p>	<p>R03</p> <p>Rimboard / VERSA-LAM® blocking. Ventilation "V" cut: $\frac{1}{3}$ of length, $\frac{1}{2}$ of depth</p> <p>Tight fit for lateral stability.</p> <p>Flange of AJS® Joists may be birdsmouth cut only at the low end of the joist. Birds-mouth cut AJS® Joist must bear fully on plate, web stiffener required each side.</p> <p>2'-6" max.</p> 	<p>R07</p> <p>Backer block (minimum 12" wide). Nail with 10-10d nails.</p> <p>Joist Hanger</p> <p>Filler block. Nail with 10-10d nails.</p> <p>Backer block required where top flange joist hanger load exceeds 250 lbs. Install tight to top flange.</p> 
<p>R05</p> <p>Simpson or USP LSTA24 strap, nailing per governing building code.</p> <p>AJS® blocking Holes cut for ventilation.</p> <p>Double-beveled wood plate.</p> <p>VERSA-LAM® LVL support beam.</p> 	<p>R06</p> <p>Simpson or USP LSTA24 strap where slope exceeds 7/12 (straps may be required for lower slopes in high-wind areas). Nailing per governing building code.</p> <p>VERSA-LAM® LVL support beam.</p> <p>Beveled web stiffener on each side.</p> <p>Simpson LSSUI or USP TMU hanger.</p> 	<p>R11</p> <p>Double joist may be required when L exceeds rafter spacing.</p> <p>Blocking as required.</p> <p>Nail outrigger through AJS® web.</p> <p>2" x _ outrigger notched around AJS® top flange. Outrigger spacing no greater than 24" on-center.</p> <p>End Wall.</p> <p>L (2'-0" max.)</p> 

LATERAL SUPPORT

- AJS® Joists must be laterally supported at the ends with hangers, AJS® rim joists, rim boards, AJS® blocking panels or x-bracing. AJS® blocking panels or x-bracing are required at cantilever supports.
- Blocking may be required at intermediate bearings for floor diaphragm per IRC in high seismic areas, consult local building official.

MINIMUM BEARING LENGTH FOR AJS® JOISTS

- $\frac{1}{2}$ inches is required at end supports. $3\frac{1}{2}$ inches is required at cantilever and intermediate supports.
- Longer bearing lengths allow higher reaction values. Refer to the building code evaluation report or the BC CALC® software.

NAILING REQUIREMENTS

- AJS® rim joist, rim board or closure panel to AJS® Joist:
 - Rims or closure panel $\frac{1}{4}$ inches thick and less: 2-8d nails, one each in the top and bottom flange.
 - AJS® 140 / 20 rim joist: 2-16d box nails, one each in the top and bottom flange.
 - AJS® 25 rim joist: Toe-nail top flange to rim joist with 2-10d box nails, one each side of flange.
- AJS® rim joist, rim board or AJS® blocking panel to support:
 - 8d nails at 6 inches on center.
 - When used for shear transfer, follow the building designer's specification.

- AJS® Joist to support:
 - 2-8d nails, one on each side of the web, placed $1\frac{1}{2}$ inches minimum from the end of the AJS® Joist to limit splitting.

- Sheathing to AJS® Joist:
 - Prescriptive residential roof sheathing nailing requires 8d common nails @ 6" o.c. on edges and @ 12" o.c. in the field IRC Table R602.3(1).
 - Maximum nail spacing for minimum lateral stability = 24".
 - 14 gauge staples may be substituted for 8d nails if the staples penetrate at least 1 inch into the joist.
 - Wood screws may be acceptable, contact local building official and/or Boise EWP Engineering for further information.

BACKER AND FILLER BLOCK DIMENSIONS

Series	Backer Block Thickness	Filler Block Thickness
AJS® 140	$1\frac{1}{8}$ " or two $\frac{1}{2}$ " wood panels	2 x ___ + $\frac{5}{8}$ " wood panel
AJS® 20	$1\frac{1}{8}$ " or two $\frac{1}{2}$ " wood panels	2 x ___ + $\frac{5}{8}$ " wood panel
AJS® 25	2 x _ lumber	Double 2 x _ lumber

- Cut backer and filler blocks to a maximum depth equal to the web depth minus $\frac{3}{4}$ " to avoid a forced fit.
- For deeper AJS® 25 Joists, stack 2x lumber or use multiple pieces of $\frac{3}{4}$ " wood panels.

WEB STIFFENER REQUIREMENTS

- See *Web Stiffener Requirements* on page 10.

PROTECT AJS® JOISTS FROM THE WEATHER

- AJS® Joists are intended only for applications that provide permanent protection from the weather. Bundles of AJS® Joists should be covered and stored off of the ground on stickers.

MAXIMUM SLOPE

- Unless otherwise noted, all roof details are valid for slopes of 12 in 12 or less.

VENTILATION

- The $\frac{1}{2}$ inch, pre-stamped knock-out holes spaced at 12 inches on center along the AJS® Joist may all be knocked out and used for cross ventilation. Deeper joists than what is structurally needed may be advantageous in ventilation design. Consult local building official and/or ventilation specialist for specific ventilation requirements.

BIRDSMOUTH CUTS

- AJS® Joists may be birdsmouth cut only at the low end support. AJS® Joists with birdsmouth cuts may cantilever up to 2'-6" past the low end support. The bottom flange must sit fully on the support and may not overhang the inside face of the support. High end supports and intermediate supports may not be birdsmouth cut.

Maximum clear span in feet and inches, based on horizontal spans.

115% and 125% Load Duration

			AJS® 140 Series 2½" Flange Width						AJS® 20 Series 2½" Flange Width												
			9½" AJS® 140			11½" AJS® 140			9½" AJS® 20			11½" AJS® 20			14" AJS® 20			16" AJS® 20			
	Live Load [psf]	Dead Load [psf]	4/12 or Less	4/12 to 8/12	8/12 to 12/12	4/12 or Less	4/12 to 8/12	8/12 to 12/12	4/12 or Less	4/12 to 8/12	8/12 to 12/12	4/12 or Less	4/12 to 8/12	8/12 to 12/12	4/12 or Less	4/12 to 8/12	8/12 to 12/12	4/12 or Less	4/12 to 8/12	8/12 to 12/12	
12" o.c.	Non-Snow 125%	20	10	25'-2"	23'-9"	22'-0"	30'-1"	28'-5"	26'-4"	27'-4"	25'-9"	23'-11"	32'-7"	30'-9"	28'-7"	37'-1"	35'-0"	32'-6"	41'-2"	38'-10"	36'-0"
		20	15	23'-10"	22'-5"	20'-8"	28'-6"	26'-9"	24'-9"	25'-10"	24'-3"	22'-5"	30'-11"	29'-0"	26'-9"	35'-2"	33'-0"	30'-5"	39'-0"	36'-7"	33'-9"
		20	20	22'-9"	21'-4"	19'-7"	27'-3"	25'-6"	23'-5"	24'-8"	23'-1"	21'-3"	29'-6"	27'-7"	25'-4"	33'-6"	31'-5"	28'-10"	37'-2"	34'-10"	32'-0"
	Snow 115%	25	10	23'-11"	22'-7"	21'-0"	28'-5"	27'-0"	25'-2"	25'-11"	24'-6"	22'-10"	31'-0"	29'-3"	27'-3"	35'-3"	33'-4"	31'-0"	39'-1"	36'-11"	34'-4"
		25	15	22'-10"	21'-6"	19'-10"	26'-6"	25'-8"	23'-9"	24'-9"	23'-3"	21'-6"	29'-7"	27'-10"	25'-9"	33'-7"	31'-8"	29'-4"	36'-11"	35'-1"	32'-6"
		30	10	22'-10"	21'-8"	20'-2"	26'-7"	25'-11"	24'-2"	24'-9"	23'-6"	21'-11"	29'-7"	28'-0"	26'-2"	33'-8"	31'-11"	29'-9"	37'-1"	35'-4"	33'-0"
		30	15	21'-11"	20'-8"	19'-2"	25'-0"	24'-5"	22'-11"	23'-9"	22'-5"	20'-10"	28'-5"	26'-9"	24'-10"	32'-4"	30'-6"	28'-3"	34'-10"	33'-10"	31'-4"
		40	10	20'-10"	19'-11"	18'-10"	23'-9"	23'-5"	22'-6"	22'-6"	21'-7"	20'-5"	26'-11"	25'-10"	24'-5"	30'-8"	29'-5"	27'-9"	33'-2"	32'-7"	30'-9"
		40	15	19'-10"	19'-4"	18'-1"	22'-7"	22'-2"	21'-7"	22'-2"	21'-0"	19'-7"	26'-6"	25'-1"	23'-5"	29'-3"	28'-7"	26'-7"	31'-7"	30'-11"	29'-6"
		50	10	19'-0"	18'-6"	17'-6"	21'-8"	21'-5"	21'-0"	20'-10"	20'-0"	19'-0"	24'-11"	23'-11"	22'-9"	28'-1"	27'-3"	25'-10"	30'-3"	29'-11"	28'-8"
50	15	18'-3"	17'-11"	17'-2"	20'-10"	20'-6"	20'-0"	20'-10"	19'-11"	18'-7"	24'-6"	23'-9"	22'-3"	26'-11"	26'-6"	25'-3"	29'-0"	28'-7"	27'-11"		
16" o.c.	Non-Snow 125%	20	10	22'-10"	21'-6"	20'-0"	27'-4"	25'-9"	23'-11"	24'-9"	23'-4"	21'-8"	29'-7"	27'-11"	25'-11"	33'-8"	31'-9"	29'-5"	37'-4"	35'-2"	32'-8"
		20	15	21'-7"	20'-3"	18'-9"	25'-6"	24'-3"	22'-5"	23'-5"	22'-0"	20'-4"	28'-0"	26'-4"	24'-3"	31'-10"	29'-11"	27'-7"	35'-4"	33'-2"	30'-7"
		20	20	20'-7"	19'-3"	17'-9"	23'-10"	23'-0"	21'-3"	22'-4"	20'-11"	19'-3"	26'-8"	25'-0"	23'-0"	30'-5"	28'-5"	26'-2"	33'-3"	31'-7"	29'-0"
	Snow 115%	25	10	21'-7"	20'-6"	19'-1"	24'-7"	24'-1"	22'-10"	23'-6"	22'-2"	20'-8"	28'-1"	26'-6"	24'-8"	31'-10"	30'-2"	28'-1"	34'-3"	33'-6"	31'-2"
		25	15	20'-1"	19'-5"	18'-0"	22'-11"	22'-4"	21'-6"	22'-5"	21'-1"	19'-6"	26'-9"	25'-2"	23'-4"	29'-8"	28'-8"	26'-7"	32'-0"	31'-1"	29'-5"
		30	10	20'-2"	19'-7"	18'-3"	23'-0"	22'-7"	21'-11"	22'-5"	21'-3"	19'-10"	26'-10"	25'-5"	23'-9"	29'-9"	28'-11"	27'-0"	32'-1"	31'-6"	29'-11"
		30	15	18'-11"	18'-6"	17'-5"	21'-7"	21'-1"	20'-5"	21'-6"	20'-4"	18'-10"	25'-6"	24'-3"	22'-6"	28'-0"	27'-4"	25'-8"	30'-2"	29'-5"	28'-5"
		40	10	18'-0"	17'-9"	17'-1"	20'-7"	20'-3"	19'-10"	20'-5"	19'-7"	18'-6"	24'-3"	23'-5"	22'-1"	26'-8"	26'-3"	25'-2"	28'-8"	28'-3"	27'-9"
		40	15	17'-2"	16'-10"	16'-4"	19'-7"	19'-2"	18'-8"	20'-1"	19'-0"	17'-9"	23'-1"	22'-7"	21'-2"	25'-4"	24'-10"	24'-1"	27'-3"	26'-9"	26'-1"
		50	10	16'-5"	16'-3"	15'-10"	18'-9"	18'-6"	18'-3"	18'-11"	18'-1"	17'-2"	22'-2"	21'-8"	20'-7"	24'-4"	24'-0"	23'-5"	26'-2"	25'-11"	25'-5"
50	15	15'-9"	15'-6"	15'-2"	18'-0"	17'-8"	17'-3"	18'-7"	18'-0"	16'-10"	21'-3"	20'-10"	20'-1"	23'-4"	22'-11"	22'-5"	25'-1"	24'-8"	23'-7"		
19.2" o.c.	Non-Snow 125%	20	10	21'-5"	20'-3"	18'-9"	25'-3"	24'-2"	22'-5"	23'-3"	21'-11"	20'-4"	27'-9"	26'-2"	24'-4"	31'-7"	29'-10"	27'-8"	35'-1"	33'-1"	30'-8"
		20	15	20'-3"	19'-1"	17'-7"	23'-3"	22'-7"	21'-1"	22'-0"	20'-8"	19'-1"	26'-4"	24'-8"	22'-10"	29'-11"	28'-1"	25'-11"	32'-6"	31'-2"	28'-9"
		20	20	19'-1"	18'-1"	16'-8"	21'-9"	21'-0"	19'-11"	21'-0"	19'-8"	18'-1"	25'-1"	23'-6"	21'-7"	28'-1"	26'-9"	24'-7"	30'-4"	29'-3"	27'-3"
	Snow 115%	25	10	19'-8"	19'-3"	17'-11"	22'-5"	21'-11"	21'-4"	22'-1"	20'-10"	19'-5"	26'-4"	24'-11"	23'-3"	29'-0"	28'-4"	26'-5"	31'-3"	30'-7"	29'-3"
		25	15	18'-4"	17'-10"	16'-11"	20'-11"	20'-4"	19'-7"	21'-0"	19'-10"	18'-4"	24'-8"	23'-8"	21'-11"	27'-1"	26'-4"	24'-11"	29'-2"	28'-5"	27'-5"
		30	10	18'-5"	18'-1"	17'-2"	21'-0"	20'-7"	20'-1"	21'-1"	19'-11"	18'-8"	24'-9"	23'-10"	22'-3"	27'-2"	26'-8"	25'-4"	29'-3"	28'-9"	28'-0"
		30	15	17'-3"	16'-10"	16'-4"	19'-8"	19'-3"	18'-7"	20'-2"	19'-1"	17'-8"	23'-3"	22'-8"	21'-2"	25'-6"	24'-11"	24'-1"	27'-6"	26'-10"	26'-0"
		40	10	16'-5"	16'-2"	15'-10"	18'-9"	18'-6"	18'-1"	19'-2"	18'-5"	17'-4"	22'-1"	21'-10"	20'-9"	24'-3"	23'-11"	23'-5"	26'-2"	25'-9"	25'-3"
		40	15	15'-8"	15'-4"	14'-11"	17'-10"	17'-6"	17'-0"	18'-5"	17'-10"	16'-8"	21'-0"	20'-7"	19'-11"	23'-1"	22'-8"	22'-0"	24'-11"	24'-2"	22'-11"
		50	10	15'-0"	14'-10"	14'-7"	17'-1"	16'-11"	16'-7"	17'-8"	17'-0"	16'-2"	20'-2"	19'-11"	19'-4"	22'-2"	21'-11"	21'-6"	23'-2"	22'-7"	21'-10"
50	15	14'-4"	14'-2"	13'-10"	16'-5"	16'-1"	15'-9"	17'-0"	16'-8"	15'-9"	19'-4"	19'-0"	18'-7"	21'-0"	20'-3"	19'-4"	21'-3"	20'-7"	19'-8"		
24" o.c.	Non-Snow 125%	20	10	19'-9"	18'-9"	17'-5"	22'-6"	22'-0"	20'-10"	21'-6"	20'-4"	18'-10"	25'-9"	24'-3"	22'-6"	29'-2"	27'-7"	25'-8"	31'-5"	30'-8"	28'-5"
		20	15	18'-3"	17'-8"	16'-3"	20'-10"	20'-2"	19'-4"	20'-4"	19'-1"	17'-8"	24'-4"	22'-10"	21'-1"	26'-11"	26'-0"	24'-0"	29'-0"	28'-2"	26'-8"
		20	20	17'-8"	16'-5"	15'-5"	19'-5"	18'-9"	17'-10"	19'-5"	18'-2"	16'-9"	22'-11"	21'-9"	20'-0"	25'-2"	24'-3"	22'-9"	27'-1"	26'-2"	24'-11"
	Snow 115%	25	10	17'-7"	17'-2"	16'-7"	20'-0"	19'-7"	19'-1"	20'-5"	19'-4"	18'-0"	23'-7"	23'-1"	21'-6"	25'-11"	25'-5"	24'-6"	27'-11"	27'-4"	26'-7"
		25	15	16'-4"	15'-11"	15'-4"	18'-8"	18'-2"	17'-6"	19'-4"	18'-4"	17'-0"	22'-0"	21'-5"	20'-4"	24'-2"	23'-6"	22'-8"	26'-1"	25'-4"	24'-3"
		30	10	16'-5"	16'-1"	15'-9"	18'-9"	18'-5"	17'-11"	19'-4"	18'-6"	17'-3"	22'-1"	21'-8"	20'-8"	24'-3"	23'-10"	23'-3"	26'-2"	25'-8"	25'-0"
		30	15	15'-5"	15'-1"	14'-7"	17'-7"	17'-2"	16'-8"	18'-2"	17'-8"	16'-5"	20'-9"	20'-3"	19'-7"	22'-10"	22'-3"	21'-7"	24'-6"	23'-4"	21'-11"
		40	10	14'-8"	14'-6"	14'-2"	16'-9"	16'-6"	16'-2"	17'-4"	17'-0"	16'-1"	19'-9"	19'-6"	19'-1"	21'-8"	21'-3"	20'-5"	22'-2"	21'-6"	20'-8"
		40	15	13'-11"	13'-8"	13'-4"	15'-11"	15'-7"	15'-2"	16'-6"	16'-2"	15'-5"	18'-9"	18'-5"	17'-8"	19'-9"	19'-0"	18'-0"	20'-1"	19'-3"	18'-3"
		50	10	13'-5"	13'-3"	13'-0"	15'-3"	15'-1"	14'-10"	15'-10"	15'-7"	14'-11"	17'-11"	17'-6"	16'-11"	18'-2"	17'-9"	17'-2"	18'-6"	18'-0"	17'-5"
50	15	12'-10"	12'-7"	12'-4"	14'-8"	14'-5"	14'-1"	15'-2"	14'-11"	14'-7"	16'-5"	15'-11"	15'-2"	16'-9"	16'-2"	15'-5"	17'-0"	16'-5"	15'-8"		

- Table values are limited by shear, moment, total load deflection equal to L/180 and live load deflection equal to L/240. Check the local building code for other deflection limits that may apply.
- Table values represent the most restrictive of simple or multiple span applications. Analyze multiple span joists with the BC Calc software if the length of any span is less than half the length of an adjacent span.
- Table values assume minimum bearing lengths without web stiffeners for joist depths of 16 inches and less. 18" joists require web stiffeners at all bearing locations.
- This table was designed to apply to a broad range of applications. It may be possible to exceed the limitations of this table by analyzing a specific application with the BC CALC® software.
- Slope roof joists at least ¼" over 12" to minimize ponding.
- Allowable spans and loads shall be adjusted and checked for wind load as required by local building code.

Roof Span Tables

Maximum clear span in feet and inches, based on horizontal spans.

115% and 125% Load Duration

			AJS® 25 Series — 9½" - 16" Depths ⅜" Web Thickness — 3½" Flange Width													
			9½" AJS® 25			11½" AJS® 25			14" AJS® 25			16" AJS® 25				
			4/12 or Less	4/12 to 8/12	8/12 to 12/12	4/12 or Less	4/12 to 8/12	8/12 to 12/12	4/12 or Less	4/12 to 8/12	8/12 to 12/12	4/12 or Less	4/12 to 8/12	8/12 to 12/12		
Clear Span	Load Type	Live Load [psf]	Dead Load [psf]	Span (ft-in)												
		12" o.c.	Non-Snow 125%	20	10	30'-0"	28'-3"	26'-3"	35'-9"	33'-9"	31'-4"	40'-7"	38'-3"	35'-6"	45'-0"	42'-5"
20	15			28'-5"	26'-8"	24'-7"	33'-10"	31'-10"	29'-4"	38'-5"	36'-1"	33'-4"	42'-7"	40'-0"	36'-11"	
20	20			27'-1"	25'-4"	23'-4"	32'-4"	30'-3"	27'-10"	36'-8"	34'-4"	31'-7"	40'-8"	38'-1"	35'-0"	
Snow 115%	25		10	28'-5"	26'-11"	25'-0"	33'-11"	32'-1"	29'-10"	38'-6"	36'-5"	33'-11"	42'-9"	40'-5"	37'-7"	
	25		15	27'-2"	25'-7"	23'-8"	32'-5"	30'-6"	28'-3"	36'-9"	34'-7"	32'-0"	40'-9"	38'-4"	35'-6"	
	30		10	27'-2"	25'-9"	24'-0"	32'-5"	30'-9"	28'-8"	36'-10"	34'-11"	32'-6"	40'-10"	38'-8"	36'-1"	
	30		15	26'-1"	24'-7"	22'-10"	31'-1"	29'-4"	27'-3"	35'-4"	33'-4"	30'-11"	39'-2"	36'-11"	34'-4"	
	40		10	24'-9"	23'-9"	22'-5"	29'-6"	28'-4"	26'-9"	33'-6"	32'-2"	30'-4"	37'-2"	35'-8"	33'-8"	
	40		15	24'-4"	23'-1"	21'-6"	29'-1"	27'-6"	25'-8"	33'-0"	31'-3"	29'-1"	36'-7"	34'-8"	32'-3"	
	50		10	22'-11"	22'-0"	20'-10"	27'-4"	26'-3"	24'-11"	31'-0"	29'-9"	28'-3"	34'-5"	33'-0"	31'-4"	
	50		15	22'-11"	21'-10"	20'-5"	27'-4"	26'-1"	24'-4"	31'-0"	29'-7"	27'-8"	34'-5"	32'-10"	30'-8"	
16" o.c.	Non-Snow 125%		20	10	27'-2"	25'-7"	23'-9"	32'-5"	30'-7"	28'-4"	36'-9"	34'-8"	32'-2"	40'-9"	38'-6"	35'-8"
			20	15	25'-8"	24'-2"	22'-3"	30'-8"	28'-10"	26'-7"	34'-10"	32'-8"	30'-2"	38'-7"	36'-3"	33'-6"
			20	20	24'-6"	22'-11"	21'-1"	29'-3"	27'-5"	25'-2"	33'-3"	31'-1"	28'-7"	36'-10"	34'-6"	31'-9"
	Snow 115%	25	10	25'-9"	24'-4"	22'-8"	30'-9"	29'-1"	27'-1"	34'-11"	33'-0"	30'-9"	38'-9"	36'-7"	34'-1"	
		25	15	24'-7"	23'-2"	21'-5"	29'-4"	27'-7"	25'-7"	33'-3"	31'-4"	29'-0"	36'-11"	34'-9"	32'-2"	
		30	10	24'-7"	23'-4"	21'-9"	29'-5"	27'-10"	26'-0"	33'-4"	31'-7"	29'-6"	37'-0"	35'-1"	32'-9"	
		30	15	23'-7"	22'-3"	20'-8"	28'-2"	26'-7"	24'-8"	32'-0"	30'-2"	28'-0"	35'-6"	33'-6"	31'-1"	
		40	10	22'-5"	21'-6"	20'-4"	26'-9"	25'-8"	24'-3"	30'-4"	29'-1"	27'-6"	33'-8"	32'-4"	30'-6"	
		40	15	22'-0"	20'-10"	19'-5"	26'-4"	24'-11"	23'-3"	29'-11"	28'-3"	26'-4"	33'-2"	31'-4"	29'-3"	
		50	10	20'-9"	19'-11"	18'-11"	24'-9"	23'-9"	22'-7"	28'-1"	27'-0"	25'-7"	31'-2"	29'-11"	28'-5"	
		50	15	20'-9"	19'-9"	18'-6"	24'-9"	23'-7"	22'-1"	28'-1"	26'-9"	25'-0"	29'-7"	28'-8"	27'-4"	
	19.2" o.c.	Non-Snow 125%	20	10	25'-6"	24'-1"	22'-4"	30'-5"	28'-9"	26'-8"	34'-7"	32'-7"	30'-3"	38'-4"	36'-2"	33'-7"
			20	15	24'-2"	22'-8"	20'-11"	28'-10"	27'-1"	25'-0"	32'-8"	30'-9"	28'-4"	36'-3"	34'-1"	31'-6"
			20	20	23'-0"	21'-7"	19'-10"	27'-6"	25'-9"	23'-8"	31'-2"	29'-3"	26'-10"	34'-7"	32'-5"	29'-10"
Snow 115%		25	10	24'-2"	22'-11"	21'-4"	28'-11"	27'-4"	25'-5"	32'-9"	31'-0"	28'-11"	36'-4"	34'-5"	32'-0"	
		25	15	23'-1"	21'-9"	20'-2"	27'-6"	25'-11"	24'-0"	31'-3"	29'-5"	27'-3"	34'-8"	32'-8"	30'-3"	
		30	10	23'-1"	21'-11"	20'-5"	27'-7"	26'-2"	24'-5"	31'-4"	29'-8"	27'-9"	34'-9"	32'-11"	30'-9"	
		30	15	22'-2"	20'-11"	19'-5"	26'-5"	25'-0"	23'-2"	30'-0"	28'-4"	26'-4"	33'-4"	31'-5"	29'-2"	
		40	10	21'-0"	20'-2"	19'-1"	25'-1"	24'-1"	22'-9"	28'-6"	27'-4"	25'-10"	31'-7"	30'-4"	28'-8"	
		40	15	20'-8"	19'-7"	18'-3"	24'-8"	23'-5"	21'-10"	28'-1"	26'-7"	24'-9"	29'-1"	28'-0"	26'-6"	
		50	10	19'-5"	18'-8"	17'-9"	23'-3"	22'-3"	21'-2"	26'-1"	25'-4"	24'-1"	26'-10"	26'-2"	25'-3"	
		50	15	19'-5"	18'-6"	17'-4"	23'-3"	22'-2"	20'-8"	23'-11"	23'-2"	22'-1"	24'-8"	23'-10"	22'-9"	
24" o.c.		Non-Snow 125%	20	10	23'-7"	22'-3"	20'-8"	28'-2"	26'-7"	24'-8"	32'-0"	30'-2"	28'-0"	35'-6"	33'-6"	31'-1"
			20	15	22'-4"	21'-0"	19'-5"	26'-8"	25'-1"	23'-2"	30'-3"	28'-5"	26'-3"	33'-7"	31'-7"	29'-2"
			20	20	21'-3"	19'-11"	18'-4"	25'-5"	23'-10"	21'-11"	28'-10"	27'-1"	24'-11"	32'-0"	30'-0"	27'-7"
	Snow 115%	25	10	22'-5"	21'-2"	19'-9"	26'-9"	25'-4"	23'-7"	30'-4"	28'-9"	26'-9"	33'-8"	31'-10"	29'-8"	
		25	15	21'-4"	20'-1"	18'-8"	25'-6"	24'-0"	22'-3"	28'-11"	27'-3"	25'-3"	31'-10"	30'-2"	28'-0"	
		30	10	21'-5"	20'-3"	18'-11"	25'-7"	24'-3"	22'-7"	29'-0"	27'-6"	25'-8"	32'-1"	30'-6"	28'-6"	
		30	15	20'-6"	19'-4"	18'-0"	24'-6"	23'-1"	21'-6"	27'-7"	26'-3"	24'-5"	28'-4"	27'-0"	25'-4"	
		40	10	19'-5"	18'-8"	17'-8"	23'-3"	22'-3"	21'-1"	24'-11"	24'-3"	23'-3"	25'-8"	24'-11"	23'-11"	
		40	15	19'-1"	18'-1"	16'-11"	21'-11"	21'-1"	19'-11"	22'-7"	21'-8"	20'-7"	23'-3"	22'-4"	21'-2"	
		50	10	17'-11"	17'-3"	16'-5"	20'-2"	19'-8"	19'-0"	20'-9"	20'-3"	19'-7"	21'-5"	20'-11"	20'-2"	
		50	15	17'-11"	17'-2"	16'-0"	18'-7"	17'-11"	17'-1"	19'-1"	18'-6"	17'-8"	19'-8"	19'-0"	18'-2"	



Maximum clear span in feet and inches, based on horizontal spans.

115% and 125% Load Duration

			AJS® 25 Series — 18" - 24" Depths 7/16" Web Thickness — 3½" Flange Width														
			18" AJS® 25			20" AJS® 25			22" AJS® 25			24" AJS® 25					
			4/12 or Less	4/12 to 8/12	8/12 to 12/12	4/12 or Less	4/12 to 8/12	8/12 to 12/12	4/12 or Less	4/12 to 8/12	8/12 to 12/12	4/12 or Less	4/12 to 8/12	8/12 to 12/12			
o.c.	Non-Snow 125%	Live Load [psf]	Dead Load [psf]														
		12"	Non-Snow 125%	20	10	48'-0"	47'-5"	44'-0"	48'-0"	48'-0"	48'-0"	48'-0"	48'-0"	48'-0"	48'-0"	48'-0"	48'-0"
20	15			47'-8"	44'-9"	41'-3"	48'-0"	48'-0"	44'-9"	48'-0"	48'-0"	48'-0"	48'-0"	48'-0"	48'-0"	48'-0"	48'-0"
20	20			45'-5"	42'-7"	39'-1"	48'-0"	46'-1"	42'-5"	48'-0"	48'-0"	45'-7"	48'-0"	48'-0"	48'-0"	48'-0"	48'-0"
Snow 115%	25		10	47'-9"	45'-2"	42'-0"	48'-0"	48'-0"	45'-6"	48'-0"	48'-0"	48'-0"	48'-0"	48'-0"	48'-0"	48'-0"	48'-0"
	25		15	45'-7"	42'-11"	39'-8"	48'-0"	46'-6"	43'-0"	48'-0"	48'-0"	46'-3"	48'-0"	48'-0"	48'-0"	48'-0"	48'-0"
	30		10	45'-8"	43'-3"	40'-4"	48'-0"	46'-10"	43'-8"	48'-0"	48'-0"	47'-0"	48'-0"	48'-0"	48'-0"	48'-0"	48'-0"
	30		15	43'-10"	41'-4"	38'-4"	47'-6"	44'-9"	41'-7"	48'-0"	48'-0"	44'-8"	48'-0"	48'-0"	48'-0"	47'-8"	48'-0"
	40		10	41'-7"	39'-10"	37'-7"	45'-1"	43'-2"	40'-9"	48'-0"	46'-5"	43'-10"	48'-0"	48'-0"	46'-10"	48'-0"	46'-10"
	40		15	40'-11"	38'-9"	36'-1"	44'-4"	42'-0"	39'-1"	46'-10"	45'-2"	42'-0"	48'-0"	47'-11"	44'-11"	44'-11"	44'-11"
	50		10	38'-6"	36'-11"	35'-1"	41'-9"	40'-0"	38'-0"	44'-11"	43'-0"	40'-10"	46'-11"	46'-0"	43'-7"	43'-7"	43'-7"
50	15	38'-6"	36'-8"	34'-3"	41'-2"	39'-9"	37'-2"	43'-1"	42'-5"	39'-11"	44'-11"	44'-3"	42'-8"	42'-8"	42'-8"		
16"	Non-Snow 125%	20	10	45'-7"	43'-0"	39'-11"	48'-0"	46'-7"	43'-3"	48'-0"	48'-0"	46'-6"	48'-0"	48'-0"	48'-0"	48'-0"	
		20	15	43'-2"	40'-7"	37'-5"	46'-10"	43'-11"	40'-7"	48'-0"	47'-3"	43'-7"	48'-0"	48'-0"	46'-7"	46'-7"	
		20	20	41'-2"	38'-7"	35'-6"	44'-8"	41'-10"	38'-5"	48'-0"	44'-11"	41'-4"	48'-0"	48'-0"	44'-2"	44'-2"	
	Snow 115%	25	10	43'-4"	40'-11"	38'-1"	44'-11"	44'-4"	41'-3"	48'-0"	47'-8"	44'-5"	48'-0"	48'-0"	47'-5"	47'-5"	47'-5"
		25	15	41'-4"	38'-11"	36'-0"	44'-9"	42'-2"	39'-0"	47'-5"	45'-4"	41'-11"	48'-0"	48'-0"	44'-10"	44'-10"	
		30	10	41'-5"	39'-2"	36'-7"	44'-10"	42'-6"	39'-8"	47'-7"	45'-8"	42'-7"	48'-0"	48'-0"	45'-6"	45'-6"	
		30	15	39'-8"	37'-5"	34'-9"	42'-9"	40'-7"	37'-8"	44'-9"	43'-8"	40'-6"	46'-8"	45'-7"	43'-3"	43'-3"	
		40	10	37'-8"	36'-2"	34'-1"	40'-8"	39'-2"	37'-0"	42'-7"	42'-0"	39'-9"	44'-5"	43'-9"	42'-5"	42'-5"	
		40	15	36'-7"	35'-1"	32'-9"	38'-8"	37'-11"	35'-5"	40'-6"	39'-9"	38'-1"	42'-3"	41'-5"	40'-4"	40'-4"	
		50	10	34'-11"	33'-6"	31'-9"	37'-2"	36'-3"	34'-5"	38'-11"	38'-5"	37'-0"	40'-7"	40'-1"	39'-5"	39'-5"	
50	15	33'-8"	33'-1"	31'-1"	35'-7"	35'-0"	33'-8"	37'-4"	36'-8"	35'-10"	38'-11"	38'-3"	37'-5"	37'-5"			
19.2"	Non-Snow 125%	20	10	42'-10"	40'-5"	37'-6"	46'-5"	43'-10"	40'-8"	48'-0"	47'-1"	43'-8"	48'-0"	48'-0"	46'-8"	46'-8"	
		20	15	40'-7"	38'-1"	35'-2"	44'-0"	41'-4"	38'-2"	47'-3"	44'-5"	41'-0"	48'-0"	47'-5"	43'-9"	43'-9"	
		20	20	38'-9"	36'-3"	33'-4"	41'-11"	39'-3"	36'-2"	45'-0"	42'-3"	38'-10"	46'-11"	45'-1"	41'-6"	41'-6"	
	Snow 115%	25	10	40'-8"	38'-6"	35'-10"	44'-1"	41'-8"	38'-10"	46'-5"	44'-10"	41'-9"	48'-0"	47'-5"	44'-7"	44'-7"	
		25	15	38'-10"	36'-6"	33'-10"	41'-4"	39'-7"	36'-8"	43'-3"	42'-2"	39'-5"	45'-2"	43'-11"	42'-1"	42'-1"	
		30	10	38'-11"	36'-10"	34'-4"	41'-5"	39'-11"	37'-3"	43'-5"	42'-8"	40'-1"	45'-3"	44'-6"	42'-9"	42'-9"	
		30	15	36'-10"	35'-2"	32'-8"	39'-0"	38'-1"	35'-5"	40'-10"	39'-11"	38'-1"	42'-7"	41'-7"	40'-3"	40'-3"	
		40	10	35'-1"	33'-11"	32'-1"	37'-1"	36'-7"	34'-9"	38'-10"	38'-4"	37'-4"	40'-6"	39'-11"	39'-2"	39'-2"	
		40	15	33'-4"	32'-9"	30'-9"	35'-4"	34'-7"	33'-4"	37'-0"	36'-3"	35'-3"	38'-7"	37'-10"	36'-10"	36'-10"	
		50	10	32'-0"	31'-5"	29'-10"	33'-11"	33'-6"	32'-4"	35'-6"	35'-1"	34'-6"	37'-0"	36'-7"	35'-11"	35'-11"	
50	15	30'-8"	30'-2"	29'-2"	32'-6"	31'-11"	31'-3"	34'-0"	33'-6"	32'-8"	35'-6"	34'-11"	34'-1"	34'-1"			
24"	Non-Snow 125%	20	10	39'-8"	37'-5"	34'-9"	43'-0"	40'-7"	37'-8"	46'-3"	43'-8"	40'-6"	48'-0"	46'-7"	43'-3"	43'-3"	
		20	15	37'-7"	35'-4"	32'-7"	40'-9"	38'-3"	35'-4"	43'-1"	41'-2"	38'-0"	44'-11"	43'-7"	40'-7"	40'-7"	
		20	20	35'-10"	33'-7"	30'-11"	38'-5"	36'-5"	33'-6"	40'-2"	38'-10"	36'-0"	41'-11"	40'-6"	38'-5"	38'-5"	
	Snow 115%	25	10	37'-5"	35'-8"	33'-2"	39'-7"	38'-8"	36'-0"	41'-6"	40'-8"	38'-8"	43'-3"	42'-4"	41'-2"	41'-2"	
		25	15	34'-11"	33'-10"	31'-4"	36'-11"	35'-11"	34'-0"	38'-8"	37'-8"	36'-4"	40'-4"	39'-3"	37'-11"	37'-11"	
		30	10	35'-0"	34'-1"	31'-10"	37'-1"	36'-5"	34'-6"	38'-10"	38'-1"	37'-1"	40'-6"	39'-9"	38'-9"	38'-9"	
		30	15	32'-11"	32'-2"	30'-3"	34'-10"	34'-0"	32'-10"	36'-6"	35'-8"	34'-6"	38'-1"	37'-2"	36'-0"	36'-0"	
		40	10	31'-4"	30'-11"	29'-8"	33'-2"	32'-8"	32'-0"	34'-9"	34'-3"	33'-7"	36'-3"	35'-8"	35'-0"	35'-0"	
		40	15	29'-10"	29'-3"	28'-5"	31'-6"	30'-11"	30'-1"	33'-0"	32'-5"	31'-6"	34'-6"	33'-9"	32'-11"	32'-11"	
		50	10	28'-7"	28'-3"	27'-8"	30'-3"	29'-11"	29'-5"	31'-9"	31'-4"	30'-10"	33'-1"	32'-8"	32'-2"	32'-2"	
50	15	27'-5"	27'-0"	26'-4"	29'-0"	28'-7"	27'-11"	30'-5"	29'-11"	29'-3"	31'-9"	31'-2"	30'-6"	30'-6"			

- Table values are limited by shear, moment, total load deflection equal to L/180 and live load deflection equal to L/240. Check the local building code for other deflection limits that may apply.
- Table values represent the most restrictive of simple or multiple span applications. Analyze multiple span joists with the BC Calc software if the length of any span is less than half the length of an adjacent span.
- Table values assume minimum bearing lengths without web stiffeners for joist depths of 16 inches and less. 18" joists require web stiffeners at all bearing locations.

- This table was designed to apply to a broad range of applications. It may be possible to exceed the limitations of this table by analyzing a specific application with the BC CALC® software.
- Slope roof joists at least ¼" over 12" to minimize ponding.
- Allowable spans and loads shall be adjusted and checked for wind load as required by local building code.

Allowable Uniform Roof Load (in pounds per linear foot [PLF])

115% and 125% Load Duration

Use of these tables should be limited to roof slopes of 3½" per foot or less.
For steeper slopes, see pages 15-17.

Span Length	AJS® 140 Series 2½" Flange Width						AJS® 20 Series 2½" Flange Width											
	9½" AJS® 140			11⅞" AJS® 140			9½" AJS® 20			11⅞" AJS® 20			14" AJS® 20			16" AJS® 20		
	Total Load		Deflect.	Total Load		Deflect.	Total Load		Deflect.	Total Load		Deflect.	Total Load		Deflect.	Total Load		Deflect.
	Snow (115%)	Non-Snow (125%)	L/240	Snow (115%)	Non-Snow (125%)	L/240	Snow (115%)	Non-Snow (125%)	L/240	Snow (115%)	Non-Snow (125%)	L/240	Snow (115%)	Non-Snow (125%)	L/240	Snow (115%)	Non-Snow (125%)	L/240
6	353	383	-	358	389		353	383	-	358	389	-	360	392	-	364	396	-
7	302	329	-	307	334		302	329	-	307	334	-	309	336	-	312	339	-
8	264	287	-	269	292		264	287	-	269	292	-	270	294	-	273	297	-
9	235	255	-	239	259		235	255	-	239	259	-	240	261	-	242	264	-
10	211	230	-	215	233		211	230	-	215	233	-	216	235	-	218	237	-
11	182	198	-	195	212		192	209	-	195	212	-	196	213	-	198	216	-
12	153	166	-	179	194		176	191	-	179	194	-	180	196	-	182	198	-
13	130	142	-	165	179		162	177	-	165	179	-	166	180	-	168	182	-
14	112	122	-	146	158		151	164	-	153	167	-	154	168	-	156	169	-
15	98	106	-	127	138		136	147	128	143	155	-	144	156	-	145	158	-
16	86	93	85	111	121		119	129	106	134	146	-	135	147	-	136	148	-
17	76	83	71	99	107		105	115	89	126	137	-	127	138	-	128	139	-
18	68	74	60	88	96		94	99	76	119	129	-	120	130	-	121	132	-
19	61	66	51	79	86		84	85	65	109	119	108	113	123	-	115	125	-
20	55	58	44	71	77		73	73	56	99	107	93	108	117	-	109	118	-
21	50	50	38	64	70		63	63	48	89	97	81	103	112	-	104	113	-
22				59	64	56	55	55	42	81	89	71	98	106	-	99	108	-
23				54	58	49				74	81	62	90	98	-	95	103	-
24										68	72	55	82	90	80	91	99	-
25										63	64	49	76	83	71	87	95	-
26										57	57	44	70	76	63	81	89	-
27										51	51	39	65	71	57	75	82	-
28													60	66	51	70	76	69

- Total Load values are limited by shear, moment, or deflection equal to L/180.
- Deflection values (Deflect.) are limited by live load deflection equal to L/240. Check the local building code for other deflection limits that may apply.
- Both the Total Load and Deflection columns must be checked. Where a Deflection value is not shown, the Total Load value will control.
- Table values apply to either simple or multiple span joists. Span is measured center to center of the minimum required bearing length. Analyze multiple span joists with the BC CALC® software if the length of any span is less than half the length of an adjacent span.
- Slope roof joists at least ¼ inch over 12 inches to minimize ponding.
- Table values assume minimum bearing lengths without web stiffeners for joist depths of 16 inches and less.
- This table was designed to apply to a broad range of applications. It may be possible to exceed the limitations of this table by analyzing a specific application with the BC CALC® software.
- Allowable spans and loads shall be adjusted and checked for wind load as required by local building code.

Allowable Uniform Roof Load (in pounds per linear foot [PLF])

115% and 125% Load Duration

Use of these tables should be limited to roof slopes of 3½" per foot or less.
For steeper slopes, see pages 15-17.

Span Length	AJS® 25 Series — 9½" - 16" Depths 3/8" Web Thickness — 3½" Flange Width											
	9½" AJS® 25			11⅞" AJS® 25			14" AJS® 25			16" AJS® 25		
	Total Load		Deflect.	Total Load		Deflect.	Total Load		Deflect.	Total Load		Deflect.
	Snow (115%)	Non-Snow (125%)	L/240	Snow (115%)	Non-Snow (125%)	L/240	Snow (115%)	Non-Snow (125%)	L/240	Snow (115%)	Non-Snow (125%)	L/240
6	356	387	-	358	389	-	360	392	-	364	396	-
7	305	332	-	307	334	-	309	336	-	312	339	-
8	267	290	-	269	292	-	270	294	-	273	297	-
9	237	258	-	239	259	-	240	261	-	242	264	-
10	214	232	-	215	233	-	216	235	-	218	237	-
11	194	211	-	195	212	-	196	213	-	198	216	-
12	178	193	-	179	194	-	180	196	-	182	198	-
13	164	179	-	165	179	-	166	180	-	168	182	-
14	152	166	-	153	167	-	154	168	-	156	169	-
15	142	155	-	143	155	-	144	156	-	145	158	-
16	133	145	-	134	146	-	135	147	-	136	148	-
17	125	136	116	126	137	-	127	138	-	128	139	-
18	118	129	99	119	129	-	120	130	-	121	132	-
19	111	111	84	113	123	-	113	123	-	115	125	-
20	95	95	73	107	116	-	108	117	-	109	118	-
21	83	83	63	102	111	-	103	112	-	104	113	-
22	72	72	55	97	106	92	98	106	-	99	108	-
23	64	64	49	93	101	81	94	102	-	95	103	-
24	56	56	43	89	94	72	90	98	-	91	99	-
25	50	50	38	83	83	64	86	94	-	87	95	-
26				74	74	57	83	90	82	84	91	-
27				67	67	51	80	87	73	80	88	-
28				60	60	46	77	84	66	78	84	-
29				54	54	41	74	78	60	75	81	-
30							71	71	54	72	79	-
31							64	64	49	70	76	66
32							59	59	45	68	74	60
33							53	53	41	66	72	55
34										64	66	51
35												

- Total Load values are limited by shear, moment, or deflection equal to L/180.
- Deflection values (Deflect.) are limited by live load deflection equal to L/240. Check the local building code for other deflection limits that may apply.
- Both the Total Load and Deflection columns must be checked. Where a Deflection value is not shown, the Total Load value will control.
- Table values apply to either simple or multiple span joists. Span is measured center to center of the minimum required bearing length. Analyze multiple span joists with the BC CALC® software if the length of any span is less than half the length of an adjacent span.
- Slope roof joists at least ¼ inch over 12 inches to minimize ponding.
- Table values assume minimum bearing lengths without web stiffeners for joist depths of 16 inches and less. 18" joists require web stiffeners at all bearing locations.
- This table was designed to apply to a broad range of applications. It may be possible to exceed the limitations of this table by analyzing a specific application with the BC CALC® software.
- Allowable spans and loads shall be adjusted and checked for wind load as required by local building code.

Allowable Uniform Roof Load (in pounds per linear foot [PLF])

115% and 125% Load Duration

Use of these tables should be limited to roof slopes of 3½" per foot or less.
For steeper slopes, see pages 15-17.

Span Length	AJS® 25 Series — 18" - 24" Depths 7/16" Web Thickness — 3½" Flange Width											
	18" AJS® 25			20" AJS® 25			22" AJS® 25			24" AJS® 25		
	Total Load		Deflect.	Total Load		Deflect.	Total Load		Deflect.	Total Load		Deflect.
	Snow (115%)	Non-Snow (125%)	L/240	Snow (115%)	Non-Snow (125%)	L/240	Snow (115%)	Non-Snow (125%)	L/240	Snow (115%)	Non-Snow (125%)	L/240
6	09	770	-	767	834	-	785	854	-	803	873	-
7	607	660	-	658	715	-	673	732	-	688	748	-
8	531	578	-	575	625	-	589	640	-	602	654	-
9	472	513	-	511	556	-	523	569	-	535	582	-
10	425	462	-	460	500	-	471	512	-	481	523	-
11	386	420	-	418	455	-	428	465	-	438	476	-
12	354	385	-	383	417	-	392	427	-	401	436	-
13	327	355	-	354	385	-	362	394	-	370	402	-
14	303	330	-	329	357	-	336	366	-	344	374	-
15	283	308	-	307	333	-	314	341	-	321	349	-
16	265	289	-	287	312	-	294	320	-	301	327	-
17	250	272	-	271	294	-	277	301	-	283	308	-
18	236	256	-	255	278	-	261	284	-	267	291	-
19	223	243	-	242	263	-	248	269	-	253	275	-
20	212	231	-	230	250	-	235	256	-	240	261	-
21	202	220	-	219	238	-	224	244	-	229	249	-
22	193	210	-	209	227	-	214	232	-	219	238	-
23	185	201	-	200	217	-	205	222	-	209	227	-
24	171	186	-	191	208	-	196	213	-	200	218	-
25	158	172	-	177	192	-	188	205	-	192	209	-
26	146	159	-	163	177	-	179	195	-	185	201	-
27	135	147	-	151	164	-	166	180	-	178	194	-
28	126	137	124	141	153	-	154	168	-	168	182	-
29	117	127	112	131	142	-	144	156	-	156	170	-
30	109	119	101	122	133	-	134	146	-	146	159	-
31	102	111	92	115	125	-	126	137	-	137	149	-
32	96	105	84	108	117	106	118	128	-	128	139	-
33	90	98	77	101	110	97	111	121	-	121	131	-
34	85	92	70	95	104	89	104	114	-	114	123	-
35	80	85	65	90	98	82	99	107	-	107	117	-
36	76	78	59	85	92	75	93	101	-	101	110	-
37	72	72	55	80	87	69	88	96	86	96	104	-
38	66	66	51	76	83	64	84	91	79	91	99	-
39	62	62	47	72	78	60	79	86	74	86	94	-
40	57	57	44	69	72	55	75	82	68	82	89	-

AJS® Joist Series	Depth [inches]	Weight [plf]	Moment [ft-lbs]	EI x 10 ⁶ [lb-in ²]	K x 10 ⁶ [lbs]	Shear [lbs]	End Reaction [lbs]				Intermediate Reaction [lbs]			
							1½" Bearing		3½" Bearing		3½" Bearing		5¼" Bearing	
							No WS ⁽¹⁾	WS ⁽²⁾	No WS ⁽¹⁾	WS ⁽²⁾	No WS ⁽¹⁾	WS ⁽²⁾	No WS ⁽¹⁾	WS ⁽²⁾
AJS® 140	9½	2.2	2450	182	5.2	1160	950	1240	1175	1480	2350	2450	2350	2450
	11⅞	2.5	3175	310	6.6	1490	955	1335	1215	1595	2390	2800	2390	2800
AJS® 20	9½	2.5	3395	232	5.2	1160	950	1240	1175	1480	2350	2450	2350	2450
	11⅞	2.8	4400	394	6.6	1490	955	1335	1215	1595	2390	2800	2390	2800
	14	3.0	5295	578	7.8	1790	960	1420	1250	1700	2430	3130	2430	3130
	16	3.3	6140	786	9.0	2065	970	1500	1285	1800	2465	3435	2465	3435
AJS® 25	9½	3.1	5370	307	5.3	1160	950	1240	1175	1480	2600	2850	2600	2850
	11⅞	3.4	6960	519	6.7	1490	955	1335	1215	1595	2690	3190	2690	3190
	14	3.7	8380	756	7.9	1790	960	1420	1250	1700	2770	3500	2770	3500
	16	3.9	9720	1028	9.1	2065	970	1505	1285	1800	2850	3800	2850	3800
	18	4.6	10975	1427	12.3	3010	N/A ⁽³⁾	2240	N/A ⁽³⁾	2620	N/A ⁽³⁾	4720	N/A ⁽³⁾	4720
	20	4.9	12270	1813	13.7	3240	N/A ⁽³⁾	2490	N/A ⁽³⁾	2980	N/A ⁽³⁾	5110	N/A ⁽³⁾	5110
	22	5.1	13455	2249	15.0	3470	N/A ⁽³⁾	2490	N/A ⁽³⁾	3150	N/A ⁽³⁾	5230	N/A ⁽³⁾	5505
	24	5.4	14625	2737	16.5	3690	N/A ⁽³⁾	2490	N/A ⁽³⁾	3320	N/A ⁽³⁾	5345	N/A ⁽³⁾	5900

NOTES:

- (1) No web stiffeners required.
- (2) Web stiffeners required.
- (3) Not applicable, web stiffeners required.
- Moment, shear and reaction values based upon a load duration of 100% and may be adjusted for other load durations.
- Design values listed are applicable for Allowable Stress Design (ASD).
- No additional repetitive member increase allowed.

$$\Delta = \frac{5wl^4}{384EI} + \frac{wl^2}{K}$$

- Δ = deflection [in]
- w = uniform load [lb/in]
- l = clear span [in]
- EI = bending stiffness [lb-in²]
- K = shear deformation coefficient [lb]

BUILDING CODE EVALUATION REPORT

- ICC ESR 1144 (IBC, IRC)

Connection on Steel Beam

F15D

Connection with Hanger on Steel Beam

F15E

Hanger Connections to AJS Headers

F16D

- Backer blocks shall be at least 12" long per hanger.
- Nails shall be clinched when possible.
- Verify capacity and fastening requirements of hangers and connectors.

Boise Rimboard Product Profiles

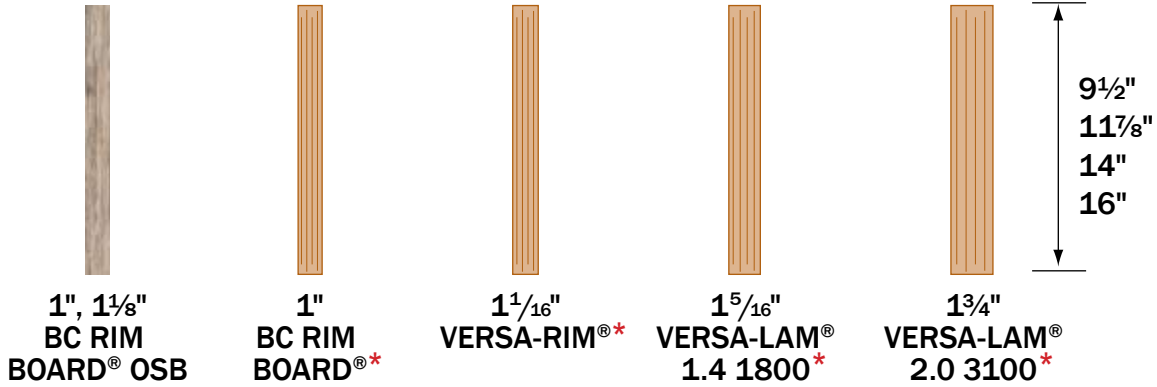

*18 – 24 inch deep rimboard are special order products, contact local supplier or Boise representative for product availability.

<p>F07 Perpendicular See chart for vertical load capacity.</p> <p>When used for shear transfer, nail to bearing plate with the same nailing capacity as required by the horizontal diaphragm schedule.</p>	<p>F07A Parallel See chart for vertical load capacity.</p> <p>When used for shear transfer, nail to bearing plate with the same nailing capacity as required by the horizontal diaphragm schedule.</p>	<p>F56</p> <p>1/2" dia through bolts (ASTM A307 Grades A&B, SAE J429 Grades 1 or 2, or higher) with washers and nuts or 1/2" dia lag screws (full penetration) 350 lb capacity for 1 1/8" & thicker rim, 300 lb capacity for 1" rim, per fastener</p> <p>Exterior wood sheathing</p> <p>Treated Ledger - Use only fasteners that are approved for use with corresponding wood treatment.</p> <p>Boise Cascade Rimboard</p> <p>Design of moisture control by others (only structural components shown above)</p>
--	--	--

Boise Rimboard Properties

Product	Vertical Load Capacity						Maximum Floor Diaphragm Lateral Capacity [lb/ft]	Specific Gravity for Lateral Nail Design	Allowable Design Values			
	Uniform [plf]			Point [lb]					Flexural Stress [lb/in ²]	Modulus of Elasticity [lb/in ²]	Horizontal Shear [lb/in ²]	Compression Perpendicular to Grain [lb/in ²]
	16" Depth & Less	18" & 20" Depth & Less	22" & 24" Depth & Less	16" Depth & Less	18" & 20" Depth & Less	22" & 24" Depth & Less						
1 1/16" VERSA-RIM ⁽¹⁾	4250	4000	—	3800	3800	—	Permitted per building code for nominal 2" thick framing diaphragms up to 205 lb/ft	0.5	Only to be used in rimboard applications			
1" BC RIM BOARD™ ⁽²⁾ & 1" BC RIM BOARD™ OSB ⁽²⁾	3300	1650	1650	3500	3500	3500	180	0.5	Limited span capabilities, see note 2			
1 1/8" BC RIM BOARD™ OSB ⁽²⁾	4400	3000	3000	3500	3500	3500	180	0.5	Limited span capabilities, see note 2			
1 5/16" VERSA-LAM® 1.4 1800 ⁽¹⁾	6000	5450	—	4450	4450	—	Permitted per building code for all nominal 2" thick framing blocked and unblocked diaphragms (4" nail spacing & greater)	0.5	1800	1,400,000	225	525
1 3/4" VERSA-LAM® 2.0 3100 ⁽¹⁾	5700	4300	—	4300	3900	—	Permitted per building code for all nominal 2" thick framing blocked and unblocked diaphragms (4" nail spacing & greater)	0.5	3100	2,000,000	285	750

Product	Closest Allowable Nail Spacing - Narrow Face [in]					
	8d Box	8d Common	10d & 12d Box	16d Box	10d, 12d Common & 16d Sinker	16d Common
1" BC RIM BOARD™ ⁽²⁾	3	3	-	-	-	-
1 1/16" VERSA-RIM ⁽¹⁾	3	4	4	4	6	6
1" or 1 1/8" BC RIM BOARD™ OSB ⁽²⁾	3	3	See note 2 for nailing information			
1 5/16" VERSA-LAM® 1.4 1800 ⁽¹⁾	3	3	3	3	4	6
1 3/4" VERSA-LAM® 2.0 3100 ⁽¹⁾	2	3	3	3	4	6

Notes

- Per ICC ESR-1040.
 - See *Performance Rated Rim Boards, APA EWS #W345J* for further product information.
- Not all products and depths may be available, check with Boise Cascade representative for product availability.

An Introduction to VERSA-LAM® Products



When you specify VERSA-LAM® laminated veneer headers/beams, you are building quality into your design. They are excellent as floor and roof framing supports or as headers for doors, windows and garage doors and columns.

Because they have no camber, VERSA-LAM® LVL products provide flatter, quieter floors, and consequently, the builder can expect happier customers with significantly fewer call backs.

VERSA-LAM® Beam Architectural Specifications

Scope: This work includes the complete furnishing and installation of all VERSA-LAM® beams as shown on the drawings, herein specified and necessary to complete the work.

Materials: Southern Pine or Douglas fir veneers, laminated in a press with all grain parallel with the length of the member. Glues used in lamination are phenol formaldehyde and isocyanate exterior-type adhesives which comply with ASTM D2559.

Design: VERSA-LAM® beams shall be sized and detailed to fit the dimensions and loads indicated on the plans. All designs shall be in accordance with allowable values developed in accordance with ASTM D5456 and listed in the governing

code evaluation service's report and section properties based upon standard engineering principles. Verification of design of the VERSA-LAM® beams by complete calculations shall be available upon request.

Drawings: Additional drawings showing layout and detail necessary for determining fit and placement in the buildings are (are not) to be provided by the supplier.

Fabrication: VERSA-LAM® beams shall be manufactured in a plant evaluated for fabrication by the governing code evaluation service and under the supervision of a third-party inspection agency listed by the corresponding evaluation service.

Storage and Installation: VERSA-LAM® beams, if stored prior to erection, shall be stored on stickers spaced a maximum of 15 ft. apart. Beams shall be stored on a dry, level surface and protected from the weather. They shall be handled with care so they are not damaged.

VERSA-LAM® beams are to be installed in accordance with the plans and Boise EWP's Installation Guide. Temporary construction loads which cause stresses beyond design limits are not permitted. Erection bracing shall be provided to assure adequate lateral support for the individual beams and the entire system until the sheathing material has been applied.

Codes: VERSA-LAM® beams shall be evaluated by a model code evaluation service.

Allowable Holes in VERSA-LAM® Beams

Notes

1. Square and rectangular holes are not permitted.
2. Round holes may be drilled or cut with a hole saw anywhere within the shaded area of the beam.
3. The horizontal distance between adjacent holes must be at least two times the size of the larger hole.
4. Do not drill more than three access holes in any four foot long section of beam.
5. The maximum round hole diameter permitted is:

Beam Depth	Max. Hole Diameter
5 1/2"	3/4"
7 1/4"	1"
9 1/4" and greater	2"

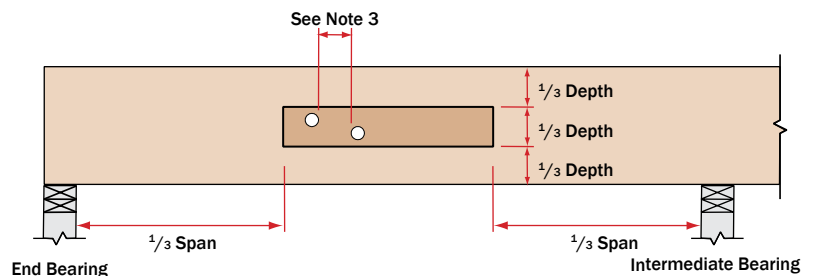

6. These limitations apply to holes drilled for plumbing or wiring access only. The size and location of holes drilled for fasteners are governed by the provisions of the *National Design Specification® for Wood Construction*.
7. Beams deflect under load. Size holes to provide clearance where required.
8. This hole chart is valid for beams supporting uniform load only. For beams supporting concentrated loads or for beams with larger holes, contact Boise EWP Engineering.

Bearing at concrete/masonry walls

Provide moisture barrier at support and lateral restraint.

1/2" air space required between concrete and wood.

Bearing for door or window header

Strap per code if top plate is not continuous over header.

Trimmers

Beam to beam connector

Verify hanger capacity with hanger literature

Bearing at column

VERSA-LAM® column

Note: Drilling permitted for standard connectors.

Slope seat cut

Sloped seat cut. Not to exceed inside face of bearing.

Provide adequate lateral support

Bevel cut

DO NOT bevel cut VERSA-LAM® beyond inside face of wall without approval from Boise EWP Engineering or BC CALC® software analysis.

Beam to concrete/masonry walls

Wood top plate must be flush with inside of wall

Hanger

Moisture barrier between concrete and wood

Bearing framing into wall

Strap per code if top plate is not continuous

VERSA-LAM® Installation Notes

- Minimum of 1/2" air space between beam and wall pocket or adequate barrier must be provided between beam and concrete/masonry.
- Adequate bearing shall be provided. If not shown on plans, please refer to load tables in your region's Specifier Guide.
- VERSA-LAM® beams are intended for interior applications only and should be kept as dry as possible during construction.
- Continuous lateral support of top of beam shall be provided (side or top bearing framing).

Multiple Member Connectors

Side-Loaded Applications

Number of Members	Maximum Uniform Side Load [plf]							
	Nailed		1/2" Dia. Through Bolt ⁽¹⁾			3/8" Dia. Through Bolt ⁽¹⁾		
	2 rows 16d Sinks @ 12" o.c.	3 rows 16d Sinks @ 12" o.c.	2 rows @ 24" o.c. staggered	2 rows @ 12" o.c. staggered	2 rows @ 6" o.c. staggered	2 rows @ 24" o.c. staggered	2 rows @ 12" o.c. staggered	2 rows @ 6" o.c. staggered
1 1/4" VERSA-LAM® (Depths of 18" and less)								
2	470	705	505	1010	2020	560	1120	2245
3 ⁽²⁾	350	525	375	755	1515	420	840	1685
4 ⁽³⁾	use bolt schedule		335	670	1345	370	745	1495
3/2" VERSA-LAM®								
2 ⁽³⁾	use bolt schedule		855	1715	N/A	1125	2250	N/A
1 1/4" VERSA-LAM® (Depths of 24")								
Number of Members	Nailed		1/2" Dia. Through Bolt ⁽¹⁾			3/8" Dia. Through Bolt ⁽¹⁾		
	3 rows 16d Sinks @ 12" o.c.	4 rows 16d Sinks @ 12" o.c.	3 rows @ 24" o.c. 8" staggered	3 rows @ 18" o.c. 6" staggered	3 rows @ 12" o.c. 4" staggered	3 rows @ 24" o.c. 8" staggered	3 rows @ 18" o.c. 6" staggered	3 rows @ 12" o.c. 4" staggered
	2	705	940	755	1010	1515	840	1120
3 ⁽²⁾	525	705	565	755	1135	630	840	1260
4 ⁽³⁾	use bolt schedule		505	670	1010	560	745	1120

1. Design values apply to common bolts that conform to ANSI/ASME standard B18.21-1981 (ASTM A307 Grades A&B, SAE J429 Grades 1 or 2, or higher). A washer not less than a standard cut washer shall be between the wood and the bolt head and between the wood and the nut. The distance from the edge of the beam to the bolt holes must be at least 2" for 1/2" bolts and 2 1/2" for 3/8" bolts. Bolt holes shall be the same diameter as the bolt.
2. The nail schedules shown apply to both sides of a 3-member beam.
3. 7" wide beams must be top-loaded or loaded from both sides (lesser side shall be no less than 25% of opposite side).

Top-Loaded Applications

For top-loaded beams and beams with side loads with less than those shown:			
Plies	Depth	Nailing	Maximum Uniform Load From One Side
(2) 1 1/4" plies	Depths 11 1/8" & less	2 rows 16d box/sinker nails @ 12" o.c.	400 plf
	Depths 14" - 18"	3 rows 16d box/sinker nails @ 12" o.c.	600 plf
	Depth = 24"	4 rows 16d box/sinker nails @ 12" o.c.	800 plf
(3) 1 1/4" plies ⁽²⁾	Depths 11 1/8" & less	2 rows 16d box/sinker nails @ 12" o.c.	300 plf
	Depths 14" - 18"	3 rows 16d box/sinker nails @ 12" o.c.	450 plf
	Depth = 24"	4 rows 16d box/sinker nails @ 12" o.c.	600 plf
(4) 1 1/4" plies	Depths 18" & less	2 rows 1/2" bolts @ 24" o.c., staggered	335 plf
	Depth = 24"	3 rows 1/2" bolts @ 24" o.c., staggered every 8"	505 plf
	Depths 18" & less	2 rows 1/2" bolts @ 24" o.c., staggered	855 plf
(2) 3/2" plies	Depth 20" - 24"	3 rows 1/2" bolts @ 24" o.c., staggered every 8"	1285 plf

1. Beams wider than 7" must be designed by the engineer of record.
2. All values in these tables may be increased by 15% for snow-load roofs and by 25% for non-snow load roofs where the building code allows.
3. Use allowable load tables or BC CALC® software to size beams.
4. An equivalent specific gravity of 0.5 may be used when designing specific connections with VERSA-LAM®.
5. Connection values are based upon the 2005 NDS.
6. **FastenMaster TrussLok, Simpson Strong-Tie SDS, and USP WS screws may also be used to connect multiple member VERSA-LAM® beams, contact Boise EWP Engineering for further information.**

Designing Connections for Multiple VERSA-LAM® Members

When using multiple ply VERSA-LAM® beams to create a wider member, the connection of the plies is as critical as determining the beam size. When side loaded beams are not connected properly, the inside plies do not support their share of the load and thus the load-carrying capacity of the full member decreases significantly. The following is an example of how to size and connect a multiple-ply VERSA-LAM® floor beam.

Given: Beam shown below is supporting residential floor load (40 psf live load, 10 psf dead load) and is spanning 16'-0". Beam depth is limited to 14".

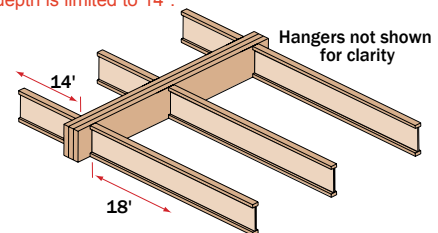

Find: A multiple 1 1/4" ply VERSA-LAM® that is adequate to support the design loads and the member's proper connection schedule.

1. Calculate the tributary width that beam is supporting:
 $14' / 2 + 18' / 2 = 16'$
2. Use PLF tables on page 25-27 of ASG or BC CALC® to size beam.
A Triple VERSA-LAM® 2.0 3100 1 1/4" x 14" is found to adequately support the design loads
3. Calculate the maximum plf load from one side (the right side in this case).
Max. Side Load = $(18' / 2) \times (40 + 10 \text{ psf}) = 450 \text{ plf}$
4. Go to the Multiple Member Connection Table, Side-Loaded Applications, 1 1/4" VERSA-LAM®, 3 members
5. The proper connection schedule must have a capacity greater than the max. side load:

Nailed: 3 rows 16d sinks @ 12" o.c.
525 plf is greater than 450 plf **OK**

Bolts: 1/2" diameter 2 rows @ 12" staggered:
755 plf is greater than 450 plf **OK**

VERSA-LAM® 2.0 3100 (100% Load Duration)

KEY TO TABLE	Top Figure - Allowable Total Load [plf]
	Middle Figure - Allowable Live Load [plf]
	Bottom Figures - Minimum Required Bearing Length at End / Intermediate Supports [inches]

Span [ft]	1½" VERSA-LAM® 2.0 3100				Double Ply 1½" VERSA-LAM® 2.0 3100 or 3½" VERSA-LAM 2.0 3100								Triple Ply 1½" VERSA-LAM® 2.0 3100 or 5½" VERSA-LAM 2.0 3100								Quadruple Ply 1½" VERSA-LAM® 2.0 3100 or 7" VERSA-LAM 2.0 3100					
	7¼"	9½"	11¾"	14"	7¼"	9½"	11¾"	14"	16"	18"	24"	9½"	11¾"	14"	16"	18"	20"	24"	11¾"	14"	16"	18"	20"	24"		
6	763	1063	1424	1795	1525	2126	2849	3590	4387	5232	5226	3189	4273	5384	6580	7848	7845	7838	5697	7179	8773	10463	10459	10451		
	762	-	-	-	1525	-	-	-	-	-	-	-	-	-	-	-	-	-	-	-	-	-	-	-		
	1.8/4.4	2.4/6.1	3.3/8.2	4.1/10.3	1.8/4.4	2.4/6.1	3.3/8.2	4.1/10.3	5/12.6	6/15	6/15	2.4/6.1	3.3/8.2	4.1/10.3	5/12.6	6/15	6/15	6/15	3.3/8.2	4.1/10.3	5/12.6	6/15	6/15	6/15		
8	479	746	979	1207	957	1492	1957	2414	2886	3402	3913	2237	2936	3622	4328	5103	5876	5870	3914	4829	5771	6803	7834	7826		
	322	724	-	-	643	1447	-	-	-	-	-	2171	-	-	-	-	-	-	-	-	-	-	-	-		
	1.5/3.7	2.3/5.7	3/7.5	3.7/9.3	1.5/3.7	2.3/5.7	3/7.5	3.7/9.3	4.4/11.1	5.2/13	6/15	2.3/5.7	3/7.5	3.7/9.3	4.4/11.1	5.2/13	6/15	6/15	3/7.5	3.7/9.3	4.4/11.1	5.2/13	6/15	6/15		
10	243	551	745	909	487	1102	1489	1817	2148	2502	3126	1653	2234	2726	3222	3753	4322	4688	2978	3635	4296	5003	5763	6251		
	165	370	724	-	329	741	1447	-	-	-	-	1111	2171	-	-	-	-	-	2894	-	-	-	-	-		
	1.5/3	2.1/5.3	2.9/7.1	3.5/8.7	1.5/3	2.1/5.3	2.9/7.1	3.5/8.7	4.1/10.3	4.8/12	6/15	2.1/5.3	2.9/7.1	3.5/8.7	4.1/10.3	4.8/12	5.5/13.8	6/15	2.9/7.1	3.5/8.7	4.1/10.3	4.8/12	5.5/13.8	6/15		
11	182	413	665	808	364	825	1330	1617	1904	2209	2839	1238	1995	2425	2856	3313	3800	4259	2659	3233	3807	4417	5067	5679		
	124	278	544	-	247	557	1087	-	-	-	-	835	1631	-	-	-	-	-	2175	-	-	-	-	-		
	1.5/3	1.7/4.4	2.8/7	3.4/8.5	1.5/3	1.7/4.4	2.8/7	3.4/8.5	4/10.1	4.7/11.7	6/15	1.7/4.4	2.8/7	3.4/8.5	4/10.1	4.7/11.7	5.4/13.4	6/15	2.8/7	3.4/8.5	4/10.1	4.7/11.7	5.4/13.4	6/15		
12	139	317	585	728	279	634	1170	1456	1709	1977	2601	950	1755	2184	2564	2965	3390	3901	2340	2912	3418	3953	4519	5201		
	95	214	419	686	191	429	837	1372	-	-	-	643	1256	2058	-	-	-	-	1675	2745	-	-	-	-		
	1.5/3	1.5/3.7	2.7/6.8	3.4/8.4	1.5/3	1.5/3.7	2.7/6.8	3.4/8.4	3.9/9.9	4.6/11.4	6/15	1.5/3.7	2.7/6.8	3.4/8.4	3.9/9.9	4.6/11.4	5.2/13	6/15	2.7/6.8	3.4/8.4	3.9/9.9	4.6/11.4	5.2/13	6/15		
13	109	248	488	662	217	496	976	1324	1550	1789	2399	744	1464	1986	2326	2683	3059	3598	1952	2647	3101	3577	4078	4797		
	75	169	329	540	150	337	659	1079	-	-	-	506	988	1619	-	-	-	-	1317	2159	-	-	-	-		
	1.5/3	1.5/3.1	2.4/6.1	3.3/8.3	1.5/3	1.5/3.1	2.4/6.1	3.3/8.3	3.9/9.7	4.5/11.2	6/15	1.5/3.1	2.4/6.1	3.3/8.3	3.9/9.7	4.5/11.2	5.1/12.7	6/15	2.4/6.1	3.3/8.3	3.9/9.7	4.5/11.2	5.1/12.7	6/15		
14	86	198	390	585	173	395	779	1171	1418	1633	2226	593	1169	1756	2128	2449	2786	3338	1558	2342	2837	3265	3715	4451		
	60	135	264	432	120	270	527	864	1290	-	-	405	791	1296	1935	-	-	-	1055	1728	2580	-	-	-		
	1.5/3	1.5/3	2.1/5.3	3.2/7.9	1.5/3	1.5/3	2.1/5.3	3.2/7.9	3.8/9.6	4.4/11	6/15	1.5/3	2.1/5.3	3.2/7.9	3.8/9.6	4.4/11	5/12.5	6/15	2.1/5.3	3.2/7.9	3.8/9.6	4.4/11	5/12.5	6/15		
15	70	160	316	509	139	320	631	1018	1307	1502	2076	479	947	1527	1960	2253	2558	3113	1262	2036	2614	3003	3410	4151		
	49	110	214	351	98	220	429	703	1049	1493	-	329	643	1054	1573	2240	-	-	858	1405	2098	2987	-	-		
	1.5/3	1.5/3	1.8/4.6	2.9/7.4	1.5/3	1.5/3	1.8/4.6	2.9/7.4	3.8/9.5	4.3/10.9	6/15	1.5/3	1.8/4.6	2.9/7.4	3.8/9.5	4.3/10.9	4.9/12.3	6/15	1.8/4.6	2.9/7.4	3.8/9.5	4.3/10.9	4.9/12.3	6/15		
16	57	131	259	427	113	262	518	854	1151	1390	1944	393	777	1281	1727	2085	2364	2917	1036	1708	2303	2780	3151	3889		
	40	90	177	289	80	181	353	579	864	1230	-	271	530	868	1296	1846	-	-	707	1158	1728	2461	-	-		
	1.5/3	1.5/3	1.6/4	2.6/6.6	1.5/3	1.5/3	1.6/4	2.6/6.6	3.6/8.9	4.3/10.7	6/15	1.5/3	1.6/4	2.6/6.6	3.6/8.9	4.3/10.7	4.9/12.2	6/15	1.6/4	2.6/6.6	3.6/8.9	4.3/10.7	4.9/12.2	6/15		
17	108	215	355	535	93	217	430	710	1018	1274	1826	325	645	1065	1527	1911	2196	2739	860	1420	2036	2547	2929	3652		
	75	147	241	375	67	151	295	483	720	1026	-	226	442	724	1081	1539	2111	-	589	965	1441	2052	2814	-		
	1.5/3	1.5/3.6	2.3/5.9	3.3/8.4	1.5/3	1.5/3	1.5/3.6	2.3/5.9	3.3/8.4	4.2/10.5	6/15	1.5/3	1.5/3.6	2.3/5.9	3.3/8.4	4.2/10.5	4.8/12	6/15	1.5/3.6	2.3/5.9	3.3/8.4	4.2/10.5	4.8/12	6/15		
18	90	180	298	477	77	181	360	596	894	1134	1701	271	540	894	1341	1701	2051	2552	720	1191	1788	2268	2735	3402		
	64	124	203	326	56	127	248	407	607	864	-	191	372	610	910	1296	1778	-	496	813	1214	1728	2371	-		
	1.5/3	1.5/3.2	2.1/5.2	3.1/7.8	1.5/3	1.5/3	1.5/3.2	2.1/5.2	3.1/7.8	4/9.9	5.9/14.8	1.5/3	1.5/3.2	2.1/5.2	3.1/7.8	4/9.9	4.8/11.9	5.9/14.8	1.5/3.2	2.1/5.2	3.1/7.8	4/9.9	4.8/11.9	5.9/14.8		
19	76	152	252	405	65	152	304	504	758	1016	1592	229	457	757	1137	1524	1863	2388	609	1009	1516	2032	2484	3184		
	54	105	173	276	48	108	211	346	516	735	-	162	316	519	774	1102	1512	-	422	691	1032	1470	2016	-		
	1.5/3	1.5/3	1.9/4.7	2.8/7	1.5/3	1.5/3	1.5/3	1.9/4.7	2.8/7	3.7/9.4	5.8/14.6	1.5/3	1.5/3	1.9/4.7	2.8/7	3.7/9.4	4.6/11.4	5.8/14.6	1.5/3	1.9/4.7	2.8/7	3.7/9.4	4.6/11.4	5.8/14.6		
20	65	130	215	345	54	129	259	430	647	915	1496	194	389	646	971	1373	1678	2243	519	861	1295	1830	2237	2991		
	46	90	148	241	41	93	181	296	442	630	1493	139	271	445	664	945	1296	2240	362	593	885	1260	1728	2987		
	1.5/3	1.5/3	1.7/4.2	2.5/6.3	1.5/3	1.5/3	1.5/3	1.7/4.2	2.5/6.3	3.6/8.9	5.8/14.5	1.5/3	1.5/3	1.7/4.2	2.5/6.3	3.6/8.9	4.3/10.8	5.8/14.5	1.5/3	1.7/4.2	2.5/6.3	3.6/8.9	4.3/10.8	5.8/14.5		
22	96	160	260	415	95	192	320	482	692	1004	142	288	480	724	1038	1382	1956	384	640	965	1383	1842	2608	-		
	68	111	180	285	70	136	223	332	473	712	1122	104	204	334	499	710	974	1683	272	445	665	947	1299	2244		
	1.5/3	1.5/3.5	2.1/5.2	3.1/7.8	1.5/3	1.5/3	1.5/3.5	2.1/5.2	3.1/7.8	4.6/11.4	6/15	1.5/3	1.5/3.5	2.1/5.2	3.1/7.8	3.9/9.9	5.6/13.9	1.5/3	1.5/3.5	2.1/5.2	3.1/7.8	3.9/9.9	5.6/13.9			
24	72	122	200	320	71	145	243	368	529	1092	106	217	365	552	793	1095	1638	290	486	736	1057	1460	2184	-		
	52	86	144	237	54	105	172	256	365	524	80	157	257	384	547	750	1296	209	343	512	729	1000	1728	-		
	1.5/3	1.5/3	1.8/4.4	2.5/6.3	1.5/3	1.5/3	1.8/4.4	2.5/6.3	3.4/8.6	5.1/12.8	6/15	1.5/3	1.5/3	1.8/4.4	2.5/6.3	3.4/8.6	5.1/12.8	1.5/3	1.5/3	1.8/4.4	2.5/6.3	3.4/8.6	5.1/12.8			
26	56	94	156	255	54	111	188	286	412	600	80	167	282	429	618	855	1390	223	376	572	824	1139	1853	-		
	41	67	111	180	42	82	135	201	287	412	680	63	124	202	302	430	590	1020	165	270	403	574	787	1359		
	1.5/3	1.5/3	1.8/4.4	2.5/6.3	1.5/3	1.5/3	1.8/4.4	2.5/6.3	3.4/8.6	5.1/12.8	6/15	1.5/3	1.5/3	1.8/4.4	2.5/6.3	3.4/8.6	5.1/12.8	1.5/3	1.5/3	1.8/4.4	2.5/6.3	3.4/8.6	5.1/12.8			
28	74	124	200	320	87	148	226	326	462	660	91	130	222	338	489	678	1188	174	296	451	652	904	1584	-		
	54	90	148	241	66	108	161	230	324	454	64	99	162	242	344	472	616	132	216	322	459	630	1088	-		
	1.5/3	1.5/3	1.8/4.6	2.5/6.3	1.5/3	1.5/3	1.8/4.6	2.5/6.3	3.4/8.6	5.1/12.8	6/15	1.5/3	1.5/3	1.8/4.6	2.5/6.3	3.4/8.6	5.1/12.8	1.5/3	1.5/3	1.8/4.6	2.5/6.3					

VERSA-LAM® 2.0 3100 (115% Load Duration)

KEY TO TABLE	Top Figure	- Allowable Total Load [plf]
	Middle Figure	- Allowable Live Load [plf]
	Bottom Figures	- Minimum Required Bearing Length at End / Intermediate Supports [inches]

Span [ft]	1½" VERSA-LAM® 2.0 3100				Double Ply 1½" VERSA-LAM® 2.0 3100 or 3½" VERSA-LAM 2.0 3100								Triple Ply 1½" VERSA-LAM® 2.0 3100 or 5½" VERSA-LAM 2.0 3100						Quadruple Ply 1½" VERSA-LAM® 2.0 3100 or 7" VERSA-LAM 2.0 3100					
	7¼"	9½"	11¾"	14"	7¼"	9½"	11¾"	14"	16"	18"	24"	9½"	11¾"	14"	16"	18"	20"	24"	11¾"	14"	16"	18"	20"	24"
6	878	1223	1639	2065	1755	2446	3278	4130	5047	5232	5226	3669	4917	6195	7570	7848	7845	7838	6556	8260	10094	10463	10459	10451
	-	-	-	-	-	-	-	-	-	-	-	-	-	-	-	-	-	-	-	-	-	-	-	-
8	2/5	2.8/7	3.8/9.4	4.7/11.8	2/5	2.8/7	3.8/9.4	4.7/11.8	5.8/14.5	6/15	6/15	2.8/7	3.8/9.4	4.7/11.8	5.8/14.5	6/15	6/15	6/15	3.8/9.4	4.7/11.8	5.8/14.5	6/15	6/15	6/15
	598	858	1126	1389	1197	1717	2252	2779	3321	3915	3913	2575	3379	4168	4981	5872	5876	5870	4505	5558	6642	7829	7834	7826
10	482	-	-	-	965	-	-	-	-	-	-	-	-	-	-	-	-	-	-	-	-	-	-	-
	1.8/4.6	2.6/6.6	3.5/8.6	4.3/10.6	1.8/4.6	2.6/6.6	3.5/8.6	4.3/10.6	5.1/12.7	6/15	6/15	2.6/6.6	3.5/8.6	4.3/10.6	5.1/12.7	6/15	6/15	6/15	3.5/8.6	4.3/10.6	5.1/12.7	6/15	6/15	6/15
11	326	637	857	1046	651	1274	1714	2092	2472	2880	3126	1912	2571	3138	3709	4320	4695	4688	3429	4184	4945	5759	6259	6251
	247	556	-	-	494	1111	-	-	-	-	-	1667	-	-	-	-	-	-	-	-	-	-	-	-
12	1.5/3.1	2.4/6.1	3.3/8.2	4/10	1.5/3.1	2.4/6.1	3.3/8.2	4/10	4.7/11.9	5.5/13.8	6/15	2.4/6.1	3.3/8.2	4/10	4.7/11.9	5.5/13.8	6/15	6/15	3.3/8.2	4/10	4.7/11.9	5.5/13.8	6/15	6/15
	244	526	765	931	487	1052	1531	1861	2192	2543	2839	1577	2296	2792	3288	3814	4265	4259	3062	3723	4383	5085	5687	5679
13	186	418	-	-	371	835	-	-	-	-	-	1253	-	-	-	-	-	-	-	-	-	-	-	-
	1.5/3	2.2/5.6	3.2/8.1	3.9/9.8	1.5/3	2.2/5.6	3.2/8.1	3.9/9.8	4.6/11.6	5.4/13.4	6/15	2.2/5.6	3.2/8.1	3.9/9.8	4.6/11.6	5.4/13.4	6/15	6/15	3.2/8.1	3.9/9.8	4.6/11.6	5.4/13.4	6/15	6/15
14	187	424	674	838	374	848	1347	1676	1968	2276	2601	1272	2021	2514	2952	3414	3903	3901	2694	3353	3936	4552	5203	5201
	143	322	628	-	286	643	1256	-	-	-	-	965	1884	-	-	-	-	-	2512	-	-	-	-	-
15	1.5/3	2/4.9	3.1/7.8	3.9/9.7	1.5/3	2/4.9	3.1/7.8	3.9/9.7	4.5/11.3	5.2/13.1	6/15	2/4.9	3.1/7.8	3.9/9.7	4.5/11.3	5.2/13.1	6/15	6/15	3.1/7.8	3.9/9.7	4.5/11.3	5.2/13.1	6/15	6/15
	146	332	573	762	292	665	1146	1524	1785	2060	2399	997	1719	2287	2678	3089	3522	3598	2292	3049	3571	4119	4696	4797
16	112	253	494	-	225	506	988	-	-	-	-	759	1482	-	-	-	-	-	1976	-	-	-	-	-
	1.5/3	1.7/4.2	2.9/7.2	3.8/9.5	1.5/3	1.7/4.2	2.9/7.2	3.8/9.5	4.5/11.2	5.1/12.9	6/15	1.7/4.2	2.9/7.2	3.8/9.5	4.5/11.2	5.1/12.9	5.9/14.7	6/15	2.9/7.2	3.8/9.5	4.5/11.2	5.1/12.9	5.9/14.7	6/15
17	116	265	493	674	233	530	987	1349	1634	1880	2226	796	1480	2023	2450	2821	3208	3338	1973	2697	3267	3761	4278	4451
	90	203	396	648	180	405	791	1296	-	-	-	608	1187	1944	-	-	-	-	1582	2593	-	-	-	-
18	1.5/3	1.5/3.6	2.7/6.7	3.6/9.1	1.5/3	1.5/3.6	2.7/6.7	3.6/9.1	4.4/11	5.1/12.7	6/15	1.5/3.6	2.7/6.7	3.6/9.1	4.4/11	5.1/12.7	5.8/14.4	6/15	2.7/6.7	3.6/9.1	4.4/11	5.1/12.7	5.8/14.4	6/15
	94	215	423	586	188	429	846	1173	1505	1730	2076	644	1268	1759	2258	2595	2946	3113	1691	2346	3011	3459	3928	4151
19	73	165	322	527	146	329	643	1054	-	-	-	494	965	1581	-	-	-	-	1286	2108	-	-	-	-
	1.5/3	1.5/3.1	2.5/6.1	3.4/8.5	1.5/3	1.5/3.1	2.5/6.1	3.4/8.5	4.3/10.9	5/12.5	6/15	1.5/3.1	2.5/6.1	3.4/8.5	4.3/10.9	5/12.5	5.7/14.2	6/15	2.5/6.1	3.4/8.5	4.3/10.9	5/12.5	5.7/14.2	6/15
20	77	176	347	515	153	352	695	1029	1327	1601	1944	528	1042	1544	1990	2402	2723	2917	1389	2058	2653	3202	3630	3889
	60	136	265	434	121	271	530	868	1296	-	-	407	795	1303	1944	-	-	-	1060	1737	2593	-	-	-
21	1.5/3	1.5/3	2.2/5.4	3.2/7.9	1.5/3	1.5/3	2.2/5.4	3.2/7.9	4.1/10.2	4.9/12.3	6/15	1.5/3	2.2/5.4	3.2/7.9	4.1/10.2	4.9/12.3	5.6/14	6/15	2.2/5.4	3.2/7.9	4.1/10.2	4.9/12.3	5.6/14	6/15
	63	146	289	455	127	292	577	910	1173	1468	1829	438	866	1365	1760	2201	2531	2743	1154	1820	2346	2935	3374	3657
22	50	113	221	362	101	226	442	724	1081	-	-	339	663	1086	1621	-	-	-	884	1448	2161	-	-	-
	1.5/3	1.5/3	1.9/4.8	3/7.5	1.5/3	1.5/3	1.9/4.8	3/7.5	3.9/9.6	4.8/12	6/15	1.5/3	1.9/4.8	3/7.5	3.9/9.6	4.8/12	5.5/13.8	6/15	1.9/4.8	3/7.5	3.9/9.6	4.8/12	5.5/13.8	6/15
23	53	122	242	399	106	244	484	799	1045	1307	1726	367	726	1198	1567	1961	2364	2588	968	1598	2089	2614	3151	3451
	42	95	186	305	85	191	372	610	910	1296	-	286	558	915	1366	1944	-	-	744	1220	1821	2593	-	-
24	1.5/3	1.5/3	1.7/4.3	2.8/7	1.5/3	1.5/3	1.7/4.3	2.8/7	3.6/9.1	4.5/11.4	6/15	1.5/3	1.7/4.3	2.8/7	3.6/9.1	4.5/11.4	5.5/13.7	6/15	1.7/4.3	2.8/7	3.6/9.1	4.5/11.4	5.5/13.7	6/15
	103	205	339	89	206	410	677	936	1171	1634	310	615	1016	1404	1757	2147	2450	820	1354	1872	2342	2862	3267	
25	81	158	259	72	162	316	519	774	1102	-	-	243	475	778	1161	1653	-	-	633	1037	1548	2204	-	-
	1.5/3	1.5/3.8	2.5/6.3	1.5/3	1.5/3	1.5/3.8	2.5/6.3	3.4/8.6	4.3/10.8	6/15	1.5/3	1.5/3.8	2.5/6.3	3.4/8.6	4.3/10.8	5.3/13.1	6/15	1.5/3.8	2.5/6.3	3.4/8.6	4.3/10.8	5.3/13.1	6/15	
26	88	175	289	75	176	350	579	843	1055	1551	263	525	868	1265	1583	1934	2326	699	1157	1686	2110	2579	3101	
	69	136	222	62	139	271	445	664	945	-	-	208	407	667	996	1418	-	-	543	889	1327	1890	-	-
27	1.5/3	1.5/3.4	2.3/5.6	1.5/3	1.5/3	1.5/3.4	2.3/5.6	3.3/8.2	4.1/10.2	6/15	1.5/3	1.5/3.4	2.3/5.6	3.3/8.2	4.1/10.2	5/12.5	6/15	1.5/3.4	2.3/5.6	3.3/8.2	4.1/10.2	5/12.5	6/15	
	65	130	216	54	130	260	431	649	869	1407	194	390	647	973	1303	1593	2111	520	862	1297	1738	2124	2815	
28	52	102	167	46	104	204	334	499	710	-	-	157	306	501	748	1065	1461	-	408	668	997	1420	1948	-
	1.5/3	1.5/3	1.9/4.7	1.5/3	1.5/3	1.9/4.7	2.8/7	3.7/9.3	6/15	1.5/3	1.5/3	1.9/4.7	2.8/7	3.7/9.3	4.5/11.3	6/15	1.5/3	1.9/4.7	2.8/7	3.7/9.3	4.5/11.3	6/15		
29	99	164	-	-	98	197	329	496	711	1259	146	296	493	744	1066	1334	1889	395	658	992	1422	1779	2518	
	79	129	-	-	80	157	257	384	547	-	-	121	236	386	576	820	1125	-	314	515	768	1094	1500	-
30	1.5/3	1.6/3.9	-	-	1.5/3	1.5/3	1.6/3.9	2.3/5.9	3.3/8.3	5.9/14.7	1.5/3	1.5/3	1.6/3.9	2.3/5.9	3.3/8.3	4.2/10.4	5.9/14.7	1.5/3	1.6/3.9	2.3/5.9	3.3/8.3	4.2/10.4	5.9/14.7	
	76	128	-	-	75	153	256	387	555	1069	112	229	383	580	833	1132	1604	305	511	773	1110	1510	2139	
31	62	101	-	-	63	124	202	302	430	1020	95	185	304	453	645	885	1529	247	405	604	860	1180	2039	
	1.5/3	1.5/3.3	-	-	1.5/3	1.5/3.3	2/5	2.8/7.1	5.4/13.5	6/15	1.5/3	1.5/3.3	2/5	2.8/7.1	3.8/9.6	5.4/13.5	6/15	1.5/3	1.5/3.3	2/5	2.8/7.1	3.8/9.6	5.4/13.5	
32	60	101	-	-	58	120	202	306	441	919	87	180	303	459	661	914	1378	240	404	612	882	1219	1837	
	49	81	-	-	51	99	162	242	344	816	76	148	243	363	517	709	1224	198	324	484	689	945	1633	
33	1.5/3	1.5/3	-	-	1.5/3	1.5/3	1.5/3	1.7/4.3	2.4/6.1	5/12.6	1.5/3	1.5/3	1.5/3	1.7/4.3	2.4/6.1	3.4/8.4	5/12.6	1.5/3	1.5/3	1.7/4.3	2.4/6.1	3.4/8.4	5/12.6	
	81	-	-	-	95	161	246	355	797	-	-	68	143	242	369	533	738	1196	190	323	492	710	984	1594
34																								

VERSA-LAM® 2.0 3100 (125% Load Duration)

KEY TO TABLE	Top Figure - Allowable Total Load [plf]
	Middle Figure - Allowable Live Load [plf]
	Bottom Figures - Minimum Required Bearing Length at End / Intermediate Supports [inches]

Span [ft]	1½" VERSA-LAM® 2.0 3100				Double Ply 1½" VERSA-LAM® 2.0 3100 or 3½" VERSA-LAM 2.0 3100								Triple Ply 1½" VERSA-LAM® 2.0 3100 or 5¼" VERSA-LAM 2.0 3100						Quadruple Ply 1½" VERSA-LAM® 2.0 3100 or 7" VERSA-LAM 2.0 3100					
	7¼"	9½"	11⅞"	14"	7¼"	9½"	11⅞"	14"	16"	18"	24"	9½"	11⅞"	14"	16"	18"	20"	24"	11⅞"	14"	16"	18"	20"	24"
6	954	1330	1782	2245	1908	2660	3564	4491	5234	5232	5226	3990	5346	6736	7851	7848	7845	7838	7128	8981	10467	10463	10459	10451
	-	-	-	-	-	-	-	-	-	-	-	-	-	-	-	-	-	-	-	-	-	-	-	-
	2.2/5.5	3.1/7.6	4.1/10.25	1/12.9	2.2/5.5	3.1/7.6	4.1/10.25	1/12.9	6/15	6/15	6/15	3.1/7.6	4.1/10.25	1/12.9	6/15	6/15	6/15	6/15	4.1/10.25	1/12.9	6/15	6/15	6/15	6/15
8	640	933	1225	1511	1279	1867	2449	3022	3611	3919	3913	2800	3674	4532	5417	5879	5876	5870	4899	6043	7222	7838	7834	7826
	482	-	-	-	965	-	-	-	-	-	-	-	-	-	-	-	-	-	-	-	-	-	-	-
	2/4.9	2.9/7.1	3.8/9.4	4.6/11.6	2/4.9	2.9/7.1	3.8/9.4	4.6/11.6	5/13.8	6/15	6/15	2.9/7.1	3.8/9.4	4.6/11.6	5/13.8	6/15	6/15	6/15	3.8/9.4	4.6/11.6	5/13.8	6/15	6/15	6/15
10	326	693	932	1138	651	1386	1864	2275	2689	3132	3126	2079	2797	3413	4033	4698	4695	4688	3729	4550	5378	6263	6259	6251
	247	556	-	-	494	1111	-	-	-	-	-	1667	-	-	-	-	-	-	-	-	-	-	-	-
	1.5/3.1	2.7/6.6	3.6/8.9	4.4/10.9	1.5/3.1	2.7/6.6	3.6/8.9	4.4/10.9	5/12.9	6/15	6/15	2.7/6.6	3.6/8.9	4.4/10.9	5/12.9	6/15	6/15	6/15	3.6/8.9	4.4/10.9	5/12.9	6/15	6/15	6/15
11	244	552	833	1012	487	1104	1665	2024	2384	2765	2839	1656	2498	3037	3576	4148	4265	4259	3330	4049	4767	5531	5687	5679
	186	418	815	-	371	835	1631	-	-	-	-	1253	2446	-	-	-	-	-	3262	-	-	-	-	-
	1.5/3	2.3/5.8	3.5/8.8	4.3/10.7	1.5/3	2.3/5.8	3.5/8.8	4.3/10.7	5/12.6	6/15	6/15	2.3/5.8	3.5/8.8	4.3/10.7	5/12.6	6/15	6/15	6/15	3.5/8.8	4.3/10.7	5/12.6	6/15	6/15	6/15
12	187	424	733	912	374	848	1465	1823	2141	2475	2601	1272	2198	2735	3211	3713	3907	3901	2931	3647	4281	4951	5209	5201
	143	322	628	-	286	643	1256	-	-	-	-	965	1884	-	-	-	-	-	2512	-	-	-	-	-
	1.5/3	2/4.9	3.4/8.4	4.2/10.5	1.5/3	2/4.9	3.4/8.4	4.2/10.5	4.2/10.5	6/15	6/15	2/4.9	3.4/8.4	4.2/10.5	4.2/10.5	6/15	6/15	6/15	3.4/8.4	4.2/10.5	4.2/10.5	6/15	6/15	6/15
13	146	332	623	829	292	665	1247	1658	1942	2240	2399	997	1870	2487	2913	3360	3604	3598	2494	3316	3884	4480	4806	4797
	112	253	494	810	225	506	988	1619	-	-	-	759	1482	2429	-	-	-	-	1976	3238	-	-	-	-
	1.5/3	1.7/4.2	3.1/7.8	4.1/10.4	1.5/3	1.7/4.2	3.1/7.8	4.1/10.4	5/12.1	6/15	6/15	1.7/4.2	3.1/7.8	4.1/10.4	5/12.1	6/15	6/15	6/15	3.1/7.8	4.1/10.4	5/12.1	6/15	6/15	6/15
14	116	265	521	734	233	530	1043	1467	1777	2046	2226	796	1564	2201	2666	3068	3345	3338	2085	2934	3554	4091	4459	4451
	90	203	396	648	180	405	791	1296	-	-	-	608	1187	1944	-	-	-	-	1582	2593	-	-	-	-
	1.5/3	1.5/3.6	2.8/7	4/9.9	1.5/3	1.5/3.6	2.8/7	4/9.9	4.8/12	6/15	6/15	1.5/3.6	2.8/7	4/9.9	4.8/12	6/15	6/15	6/15	2.8/7	4/9.9	4.8/12	6/15	6/15	6/15
15	94	215	423	638	188	429	846	1276	1638	1882	2076	644	1268	1914	2456	2823	3120	3113	1691	2552	3275	3763	4159	4151
	73	165	322	527	146	329	643	1054	1573	-	-	494	965	1581	2360	-	-	-	1286	2108	3146	-	-	-
	1.5/3	1.5/3.1	2.5/6.1	3.7/9.2	1.5/3	1.5/3.1	2.5/6.1	3.7/9.2	4.7/11.85	6/15	6/15	1.5/3.1	2.5/6.1	3.7/9.2	4.7/11.85	6/15	6/15	6/15	2.5/6.1	3.7/9.2	4.7/11.85	6/15	6/15	6/15
16	77	176	347	560	153	352	695	1120	1443	1742	1944	528	1042	1680	2165	2613	2923	2917	1389	2240	2887	3484	3897	3889
	60	136	265	434	121	271	530	868	1296	-	-	407	795	1303	1944	-	-	-	1060	1737	2593	-	-	-
	1.5/3	1.5/3	2.2/5.4	3.5/8.6	1.5/3	1.5/3	2.2/5.4	3.5/8.6	4.4/11.5	6/15	6/15	1.5/3	2.2/5.4	3.5/8.6	4.4/11.5	6/15	6/15	6/15	2.2/5.4	3.5/8.6	4.4/11.5	6/15	6/15	6/15
17	63	146	289	476	127	292	577	951	1277	1597	1829	438	866	1427	1915	2395	2749	2743	1154	1902	2553	3193	3665	3657
	50	113	221	362	101	226	442	724	1081	1539	-	339	663	1086	1621	2308	-	-	884	1448	2161	3078	-	-
	1.5/3	1.5/3	1.9/4.8	3.1/7.8	1.5/3	1.5/3	1.9/4.8	3.1/7.8	4.2/10.55	6/15	6/15	1.5/3	1.9/4.8	3.1/7.8	4.2/10.55	6/15	6/15	6/15	1.9/4.8	3.1/7.8	4.2/10.55	6/15	6/15	6/15
18	53	122	242	399	106	244	484	799	1137	1422	1726	367	726	1198	1705	2133	2572	2588	968	1598	2274	2845	3429	3451
	42	95	186	305	85	191	372	610	910	1296	-	286	558	915	1366	1944	-	-	744	1220	1821	2593	-	-
	1.5/3	1.5/3	1.7/4.3	2.8/7	1.5/3	1.5/3	1.7/4.3	2.8/7	4/9.9	6/15	6/15	1.5/3	1.7/4.3	2.8/7	4/9.9	6/15	6/15	6/15	1.7/4.3	2.8/7	4/9.9	6/15	6/15	6/15
19	103	205	339	89	206	410	677	1016	1275	1634	310	615	1016	1524	1912	2336	2450	2450	820	1354	2032	2549	3115	3267
	81	158	259	72	162	316	519	774	1102	-	-	243	475	778	1161	1653	2268	-	633	1037	1548	2204	3024	-
	1.5/3	1.5/3.8	2.5/6.3	1.5/3	1.5/3	1.5/3.8	2.5/6.3	3.7/9.3	4.7/11.7	6/15	6/15	1.5/3	1.5/3.8	2.5/6.3	3.7/9.3	4.7/11.7	6/15	6/15	6/15	1.5/3.8	2.5/6.3	3.7/9.3	4.7/11.7	6/15
20	88	175	289	75	176	350	579	869	1149	1551	263	525	868	1303	1723	2105	2326	2326	699	1157	1737	2297	2807	3101
	69	136	222	62	139	271	445	664	945	-	-	208	407	667	996	1418	1944	-	543	889	1327	1890	2593	-
	1.5/3	1.5/3.4	2.3/5.6	1.5/3	1.5/3	1.5/3.4	2.3/5.6	3.4/8.4	4.4/11.1	6/15	6/15	1.5/3	1.5/3.4	2.3/5.6	3.4/8.4	4.4/11.1	6/15	6/15	6/15	1.5/3.4	2.3/5.6	3.4/8.4	4.4/11.1	6/15
22	65	130	216	54	130	260	431	649	928	1407	194	390	647	973	1393	1735	2111	2111	520	862	1297	1857	2313	2815
	52	102	167	46	104	204	334	499	710	-	-	157	306	501	748	1065	1461	-	408	668	997	1420	1948	-
	1.5/3	1.5/3	1.9/4.7	1.5/3	1.5/3	1.5/3	1.9/4.7	2.8/7	4/9.9	6/15	6/15	1.5/3	1.5/3	1.9/4.7	2.8/7	4/9.9	6/15	6/15	6/15	1.5/3	1.9/4.7	2.8/7	4/9.9	6/15
24	99	164	-	-	98	197	329	496	711	1288	146	296	493	744	1066	1453	1932	1932	395	658	992	1422	1937	2576
	79	129	-	-	80	157	257	384	547	-	-	121	236	386	576	820	1125	-	314	515	768	1094	1500	-
	1.5/3	1.6/3.9	-	-	1.5/3	1.5/3	1.6/3.9	2.3/5.9	3.3/8.3	6/15	6/15	1.5/3	1.5/3	1.6/3.9	2.3/5.9	3.3/8.3	4.5/11.3	6/15	6/15	1.6/3.9	2.3/5.9	3.3/8.3	4.5/11.3	6/15
26	76	128	-	-	75	153	256	387	555	1164	112	229	383	580	833	1150	1747	1747	305	511	773	1110	1533	2329
	62	101	-	-	63	124	202	302	430	1020	95	185	304	453	645	885	1529	247	405	604	860	1180	2039	-
	1.5/3	1.5/3.3	-	-	1.5/3	1.5/3	1.5/3.3	2/5	2.8/7.1	5.9/14.7	6/15	1.5/3	1.5/3	1.5/3.3	2/5	2.8/7.1	3.9/9.7	5.9/14.7	1.5/3	1.5/3.3	2/5	2.8/7.1	3.9/9.7	5.9/14.7
28	60	101	-	-	58	120	202	306	441	1001	87	180	303	459	661	914	1501	1501	240	404	612	882	1219	2001
	49	81	-	-	51	99	162	242	344	816	76	148	243	363	517	709	1224	1224	198	324	484	689	945	1633
	1.5/3	1.5/3	-	-	1.5/3	1.5/3	1.5/3	1.7/4.3	2.4/6.1	5.5/13.7	6/15	1.5/3	1.5/3	1.7/4.3	2.4/6.1	3.4/8.4	5.5/13.7	6/15	6/15	1.7/4.3	2.4/6.1	3.4/8.4	5.5/13.7	6/15
30	81	-	-	-	95	161	246	355	861	68	143	242	369	533	738	129								

Closest Allowable Nail Spacing

VERSA-LAM® & VERSA-RIM® Products

Nail Size	Nailing Parallel to Glue Lines (Narrow Face) ⁽¹⁾								Nailing Perpendicular to Glue Lines (Wide Face)	
	VERSA-RIM® 1 1/16"		VERSA-LAM® 1.4 1800 Rimboard 1 5/16"		VERSA-LAM® 1 3/4"		VERSA-LAM® 3 1/2" & Wider		All Products	
	O.C. [inches]	End [inches]	O.C. [inches]	End [inches]	O.C. [inches]	End [inches]	O.C. [inches]	End [inches]	O.C. [inches]	End [inches]
8d Box	3	1 1/2	3	1 1/2	2	1	2	1 1/2	2	1 1/2
8d Common	4	3	3	2	3	2	2	1	2	1
10d & 12d Box	4	3	3	2	3	2	2	1	2	1
16d Box	4	3	3	2	3	2	2	1	2	1
10d & 12d Common	6	4	4	3	4	3	2	2	2	2
16d Sinker	6	4	4	3	4	3	2	2	2	2
16d Common	6	4	6	4	6	3	2	2	2	2

Nailing Parallel to Glue Lines (Narrow Face)

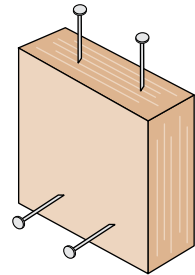

Nailing Perpendicular to Glue Lines (Wide Face)

Nailing Notes

1) For 1 3/4" thickness and greater, 2 rows of nails (such as for a metal strap) are allowed (use 1/2" minimum offset between rows and stagger nails).

- Offset and stagger nail rows from floor sheathing and wall sole plate.
- Simpson Strong-Tie A35 and LPT4 connectors may be attached to the side VERSA-LAM®/VERSA-RIM®. Use nails as specified by Simpson Strong-Tie.

VERSA-LAM® Design Values

Grade	Width [in]	Depth [in]	Weight [lb/ft]	Allowable Shear [lb]	Allowable Moment [ft-lb]	Moment of Inertia [in ⁴]	Grade	Width [in]	Depth [in]	Weight [lb/ft]	Allowable Shear [lb]	Allowable Moment [ft-lb]	Moment of Inertia [in ⁴]	
VERSA-STUD® 1.7 2650	1 1/2	3 1/2	1.5	998	776	5.4	VERSA-LAM® 2.0 3100	5 1/4	5 1/4	8.0	5237	6830	63.3	
		5 1/2	2.4	1568	1821	20.8			5 1/2	8.4	5486	7457	72.8	
		7 1/4	3.2	2066	3069	47.6			7 1/4	11.0	7232	12566	166.7	
VERSA-LAM® 2.0 3100	1 3/4	3 1/2	1.8	1164	1058	6.3			9 1/2	14.5	9476	20937	375.1	
		5 1/2	2.8	1829	2486	24.3			11 1/4	17.1	11222	28814	622.9	
		7 1/4	3.7	2411	4189	55.6			11 5/8	18.1	11845	31913	732.6	
		9 1/4	4.7	3076	6636	115.4			14	21.3	13965	43552	1200.5	
		9 1/2	4.8	3159	6979	125.0			16	24.4	15960	56046	1792.0	
		11 1/4	5.7	3741	9605	207.6			18	27.4	17955	70011	2551.5	
		11 5/8	6.0	3948	10638	244.2			20	30.4	19950	85428	3500.0	
		14	7.1	4655	14517	400.2			24	36.5	23940	120549	6048.0	
		16	8.1	5320	18682	597.3			7	9 1/4	16.6	12303	26544	461.7
		18	9.1	5985	23337	850.5				9 1/2	17.1	12635	27916	500.1
		24	12.2	7980	40183	2016.0				11 1/4	20.2	14963	38419	830.6
		VERSA-LAM® 2.0 3100	3 1/2	5 1/2	5.6	3658				4971	48.5	11 5/8	21.4	15794
7 1/4	7.4			4821	8377	111.1	14	25.2		18620	58069	1600.7		
9 1/4	9.4			6151	13272	230.8	16	28.8		21280	74728	2389.3		
9 1/2	9.6			6318	13958	250.1	18	32.4		23940	93348	3402.0		
11 1/4	11.4			7481	19210	415.3	20	36.0		26600	113904	4666.7		
11 5/8	12.1			7897	21275	488.4	24	43.2	31920	160732	8064.0			
14	14.2			9310	29035	800.3								
16	16.2			10640	37364	1194.7								
18	18.3	11970	46674	1701.0										
20	20.3	13300	56952	2333.3										

Design Property	Grade	Modulus of Elasticity	Bending	Horizontal Shear	Tension Parallel to Grain	Compression Parallel to Grain	Compression Perpendicular to Grain	Equivalent Specific Gravity for Fastener Design (SG)
		E (x 10 ⁶ psi) ⁽¹⁾	F _b (psi) ⁽²⁾⁽³⁾	F _v (psi) ⁽²⁾⁽⁴⁾	F _t (psi) ⁽²⁾⁽⁵⁾	F _c (psi) ⁽²⁾	F _{c⊥} (psi) ⁽¹⁾⁽⁶⁾	
VERSA-LAM® Beams	2.0 3100	2.0	3100	285	2150	3000	750	0.5
VERSA-LAM® Columns & Studs	1.7 2650	1.7	2650	285	1650	3000	750	0.5

1. This value cannot be adjusted for load duration.
 2. This value is based upon a load duration of 100% and may be adjusted for other load durations.
 3. Fiber stress bending value shall be multiplied by the depth factor, (12/d)^{1/3} where d = member depth [in].
 4. Stress applied perpendicular to the glue lines.
 5. Tension value shall be multiplied by a length factor, (4/L)^{1/8} where L = member length [ft]. Use L = 4 for members less than four feet long.
 6. Stress applied parallel to the glue lines.
- * Design properties are limited to dry conditions of use where the maximum moisture content of the material will not exceed 16%.

The same properties that make VERSA-LAM® beams great, also make them highly suitable for wood columns. In VERSA-LAM® columns, you'll find none of the deep checks, cracks or twists that can plague solid wood columns.

VERSA-LAM® 1.7 2650 Columns

Column Length [ft]	Allowable Axial Load (lb)																	
	3½" x 3½"			3½" x 5¼"			3½" x 7"			5¼" x 5¼"			5¼" x 7"			7" x 7"		
	100%	115%	125%	100%	115%	125%	100%	115%	125%	100%	115%	125%	100%	115%	125%	100%	115%	125%
4	14,700	16,090	16,930	22,070	24,165	25,430	29,450	32,240	33,920									
5	12,270	13,150	13,660	18,425	19,740	20,515	24,580	26,330	27,365									
6	10,080	10,650	10,980	15,140	15,995	16,495	20,195	21,335	22,000	33,070	36,220	38,110						
7	8,310	8,705	8,930	12,480	13,075	13,415	16,650	17,435	17,890	29,420	31,730	33,085						
8	6,930	7,205	7,370	10,405	10,825	11,070	13,880	14,440	14,760	25,875	27,570	28,565	34,525	36,790	38,115			
9	5,840	6,050	6,160	8,770	9,080	9,260	11,700	12,115	12,350	22,690	23,970	24,715	30,275	31,985	32,980			
10	4,980	5,135	5,225	7,480	7,715	7,850	9,975	10,290	10,470	19,930	20,920	21,495	26,600	27,920	28,685			
11	4,290	4,410	4,480	6,445	6,625	6,730	8,595	8,835	8,975	17,585	18,375	18,820	23,465	24,510	25,125			
12	3,730	3,825	3,880	5,600	5,745	5,830	7,475	7,665	7,775	15,590	16,220	16,585	20,805	21,650	22,130			
13	3,270	3,350	3,390	4,915	5,030	5,095	6,555	6,710	6,795	13,895	14,410	14,700	18,545	19,225	19,620			
14	2,890	2,950	2,990	4,340	4,435	4,490	5,790	5,915	5,990	12,450	12,870	13,115	16,615	17,180	17,500	33,260	34,825	35,740
15										11,210	11,560	11,760	14,960	15,425	15,695	30,325	31,645	32,395
16										10,135	10,430	10,600	13,525	13,920	14,150	27,720	28,835	29,490
17										9,205	9,455	9,600	12,285	12,620	12,810	25,415	26,375	26,920
18										8,395	8,610	8,735	11,205	11,495	11,655	23,370	24,195	24,665
19										7,685	7,870	7,975	10,260	10,505	10,645	21,550	22,270	22,670
20										7,060	7,220	7,310	9,420	9,635	9,760	19,925	20,550	20,910
21										6,505	6,645	6,725	8,680	8,870	8,980	18,475	19,020	19,330
22																17,165	17,650	17,925
23																15,990	16,420	16,660
24																14,930	15,310	15,525

Allowable Design Stresses		Notes
Modulus of Elasticity: $E = 1.7 \times 10^6$ psi		
Bending:	Parallel to Gluelines (Beam): $F_b = 2650 \cdot (12/d)^{1/9}$ psi	
	Perp to Gluelines (Plank): $F_b = 2400 \cdot (12/d)^{1/9}$ psi	
Compression Parallel to Grain: $F_{c } = 3000$ psi		
Compression Perpendicular to Grain:		
	Parallel to Gluelines (Beam): $F_{c\perp} = 750$ psi	
	Perp to Gluelines (Plank): $F_{c\perp} = 450$ psi	
Tension Parallel to Grain: $F_t = 1650$ psi		

VERSA-STUD® 1.7 2650

Allowable Design Values

Product	Bending F_b [psi]	Compression Parallel to Grain F_c [psi]	Modulus of Elasticity E [psi]	Horizontal Shear F_v [psi]
VERSA-STUD® 1.7 2650	2650	3000	1,700,000	285
Spruce Pine Fir (North) # 1 / 2 Grade	875	1150	1,400,000	135
Hem-Fir # 2 Grade	850	1300	1,300,000	150
Western Woods # 2 Grade	675	900	1,000,000	135

Notes:

- Design values are for loads applied to the narrow face of the studs.
- Dimension lumber values taken from 2005 Edition, *NDS Design Values for Wood Construction* (per 2006 IBC/IRC).
- Repetitive member and size factors have not been applied.
- For further design information, please see VERSA-STUD 1.7 2650 Eastern Tall Wall Guide.

BC FRAMER® CADD Framing Software

BC FRAMER® is an easy-to-use, stand-alone computer-aided drafting program with 3D capability designed to quickly create floor and roof framing layouts.

Draw walls, add framing areas, locate beams and rough openings, define cross-sections and on-center spacing. In minutes, BC FRAMER® frames your layout, builds a piece and price report, creates a framing drawing with schedule, all using Boise Engineered Wood Products.

Easy-to-use editing and drawing tools allow flexibility when modifying members and adding details, symbols and accessories.

Training classes for BC FRAMER® are provided at Boise EWP's training centers located in Oregon, Louisiana and Georgia.

For questions, comments or a free demonstration CD visit our website at www.BC.com/ewp or email us at EWPSupport@BC.com. Information can also be obtained at 1-800-405-5969.

RECOMMENDED HARDWARE

- Current Pentium Processor
- 1GB RAM (min.)
- Microsoft® Intellimouse
- Windows 7, Vista or XP Professional

Improvements in capacity or speed of these components will yield better performance.

Give Us a Try!

BC CALC® Sizing Software

BC CALC® is Boise's sizing software for AJS® Joists and VERSA-LAM® Beams.

BC CALC® is simple to use, yet flexible enough to analyze most joist and beam applications. Span, load and hole information entered by the user is analyzed by the program to correctly size Boise Engineered Wood Products. A comprehensive Help File menu is included in the program.

BC CALC® is available to designers, architects and engineers on CD-ROM or by download at www.BC.com/ewp. Hardware requirements include Pentium® Processor with a recommended minimum of 512MB RAM. To order BC CALC®, call 1-800-405-5969 or email EWPSupport@BC.com.

To request a CD or Download of BC CALC US, <http://www.bc.com/wood/ewp/software/bccalc/order/US-calc-form.html>

Use the New Design toolbar to create a new design

Use the Loads toolbar to add loads

Use the Holes toolbar to add holes

Member Diagram: Same as BC CALC 2001a

Double-Click on Analysis to analyze design

Double-Click on Cautions to analyze design and display Report

Double-Click on any item to display and change design parameters

View tabs - Click or Ctrl+D, Ctrl+R, Ctrl+E to see the Design window, Report, or Engineering Data

Project Manager tab

Design Tabs - Each design has its own. Click or Ctrl+Arrow to select.

Data Entry Tabs Enter design

Click Print button to print selected designs

Create sub-folders to organize your designs

Double-click on design name or icon to go to a design

Use the Hide/Show checkboxes to hide or show each design - open Window menu to hide/show all designs

Click here to enter project information

Open Window menu to hide/show all designs

Click to analyze all designs

- Drag column border to resize;

- Drag column heading to move;

- Right-Click to add/drop columns

Right-Click in the Designs column to create new folders and designs

Columns show analysis results, double-click to go to design

Project Manager Window



Boise EWP is proud to introduce BC COLUMN™. BC COLUMN™ is new software that will allow customers the ability to design columns using Boise Engineered Wood Products.

Using BC COLUMN™, users can quickly:

- Design a column or stud using Boise Engineered Wood Products.
- Add gravity and out-of-plane lateral loads.
- Add bracing/supports.
- Select and test products in the design.
- Refine performance factors.
- Print design reports.

The steps are simple. To use:

- Launch BC COLUMN™.
- Enter project information.
- Specify the design and select a product.
- Describe the type of column or stud, its height and its bracing.
- Adjust the axial load and add additional out-of-plane lateral loads.
- Select a product. Specify the Deflection.
- Specify the column/stud deflection.
- Analyze and refine designs.
- Review and print design reports.

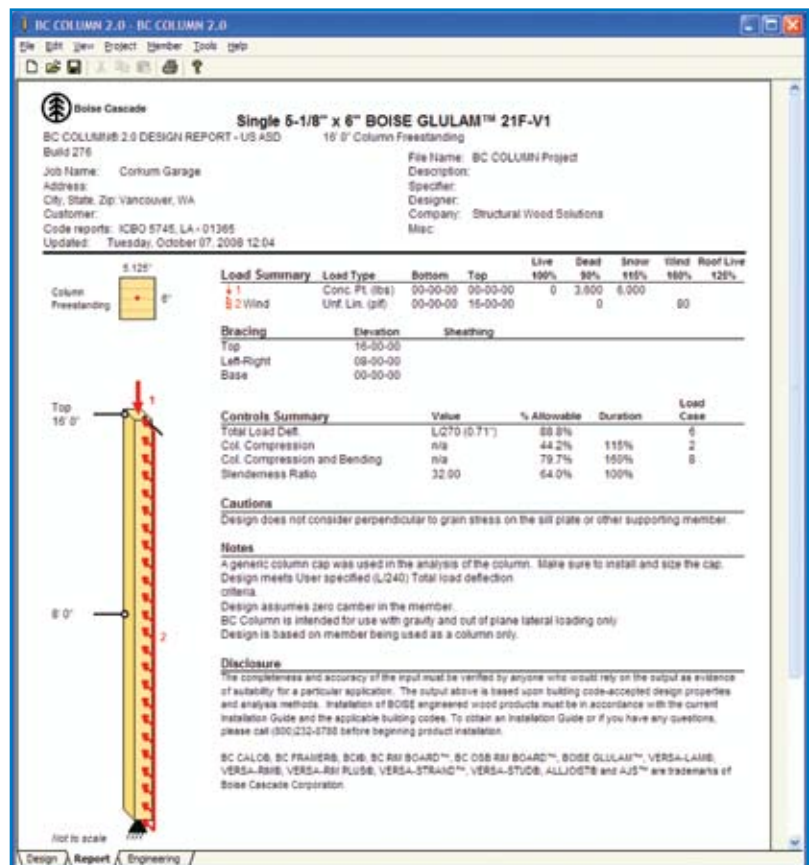
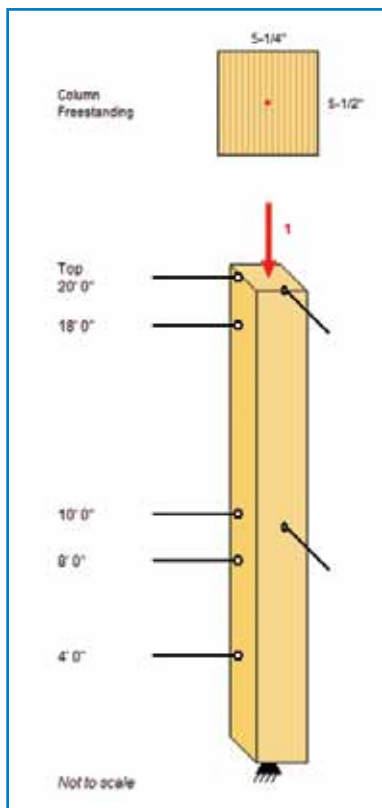
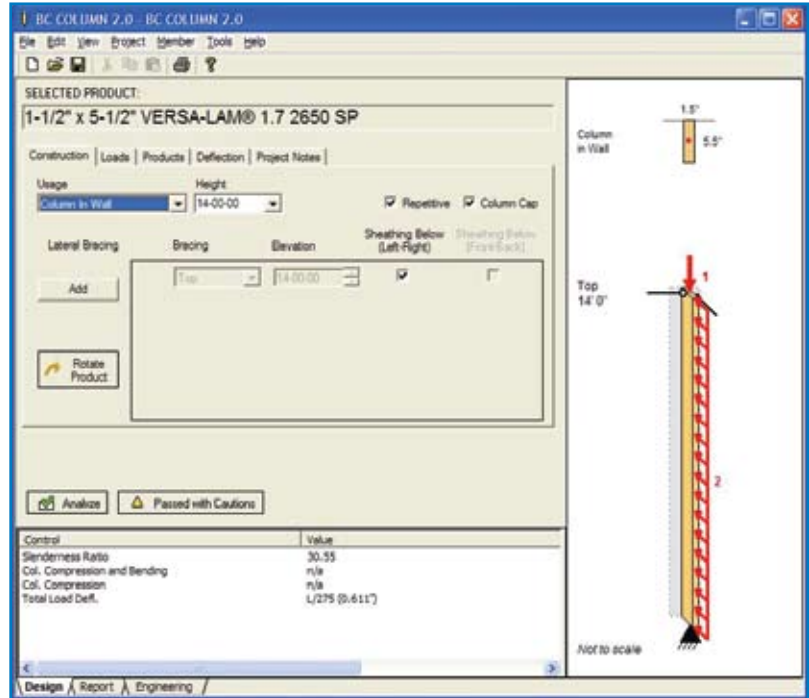

BC COLUMN is installed with BC CALC for the US market ONLY. To request a CD or Download of BC CALC/BC COLUMN US <http://www.bc.com/wood/ewp/software/bccalc/order/US-calc-form.html>

Single Joist - Top Flange

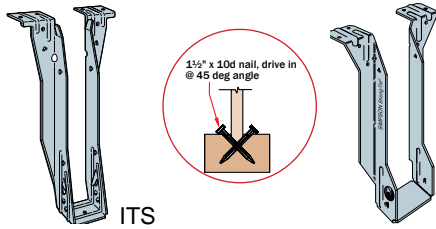

Joist Depth	AJS®	Hanger	Capacity [lbs]	Nailing	
				Header	Joist
9½"	20/140	ITS2.56/9.5	1006	6-10d	—
	25	ITS3.56/9.5	1006	6-10d	—
11⅞"	20/140	ITS2.56/11.88	1020	6-10d	—
	25	ITS3.56/11.88	1020	6-10d	—
14"	20/140	ITS2.56/14	1032	6-10d	—
	25	ITS3.56/14	1032	6-10d	—
16"	20/140	ITS2.56/16	1048	6-10d	—
	25	ITS3.56/16	1048	6-10d	—
18"	25	MIT418	2305	8-16d	2-10dx1½"
20"	25	MIT420	2305	8-16d	2-10dx1½"
22"	25	MIT422	2550	10-16d	2-10dx1½"
24"	25	MIT424	2550	10-16d	2-10dx1½"

Single Joist - Face Mount

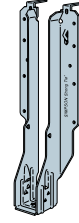

Joist Depth	AJS®	Hanger	Capacity [lbs]	Nailing	
				Header	Joist
9½"	20/140	IUS2.56/9.5	935	8-10d	—
	25	IUS3.56/9.5	1006	10-10d	—
11⅞"	20/140	IUS2.56/11.88	1020	10-10d	—
	25	IUS3.56/11.88	1020	12-10d	—
14"	20/140	IUS2.56/14	1032	12-10d	—
	25	IUS3.56/14	1032	12-10d	—
16"	20/140	IUS2.56/16	1048	14-10d	—
	25	IUS3.56/16	1048	14-10d	—
18"	25	MIU3.56/18	2430	26-16d	2-10dx1½"
20"	25	MIU3.56/20	2735	28-16d	2-10dx1½"
22"	25	MIU3.56/20	2820	28-16d	2-10dx1½"
24"	25	MIU3.56/20	2905	28-16d	2-10dx1½"

Double Joist - Top Flange

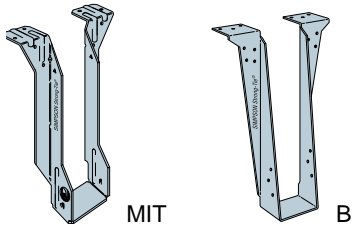

Joist Depth	AJS®	Hanger	Capacity [lbs]	Nailing	
				Header	Joist
9½"	20/140	MIT39.5-2	2125	8-16d	2-10dx1½"
	25	B7.12/9.5	2720	14-16d	6-16d
11⅞"	20/140	MIT311.88-2	2170	8-16d	2-10dx1½"
	25	B7.12/11.88	2930	14-16d	6-16d
14"	20/140	MIT314-2	2210	8-16d	2-10dx1½"
	25	B7.12/14	3120	14-16d	6-16d
16"	20/140	MIT5.12/16	2255	8-16d	2-10dx1½"
	25	B7.12/16	3305	14-16d	6-16d
18"	25	B7.12/18	3800	14-16d	6-16d
20"	25	B7.12/20	3800	14-16d	6-16d
22"	25	B7.12/22	3800	14-16d	6-16d
24"	25	B7.12/24	3800	14-16d	6-16d

Double Joist - Face Mount

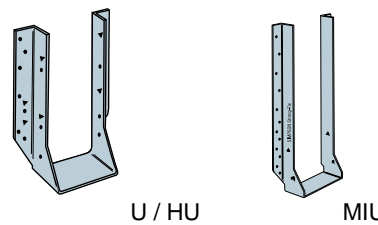

Joist Depth	AJS®	Hanger	Capacity [lbs]	Nailing	
				Header	Joist
9½"	20/140	MIU5.12/9	2125	12-16d	2-10dx1½"
	25	HU410-2	2410	18-16d	8-16d
11⅞"	20/140	MIU5.12/11	2170	16-16d	2-10dx1½"
	25	HU412-2	2930	22-16d	8-16d
14"	20/140	MIU5.12/14	2210	20-16d	2-10dx1½"
	25	HU414-2	3120	26-16d	8-16d
16"	20/140	MIU5.12/16	2255	24-16d	2-10dx1½"
	25	HU414-2	3305	26-16d	12-16d
18"	25	HU414-2	3485	26-16d	12-16d
20"	25	HU414-2	3485	26-16d	12-16d
22"	25	HU414-2	3485	26-16d	12-16d
24"	25	—	—	—	—

Face Mount Skewed 45° Joist Hanger

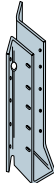

Joist Depth	AJS®	Hanger	SUR/L Capacity [lbs]	Nailing	
				Header	Joist
9½"	20/140	SUR/L2.56/9	1139	14-16d	2-10dx1½"
	25	SUR/L410	1076	14-16d	6-16d
11⅞"	20/140	SUR/L2.56/11	1174	16-16d	2-10dx1½"
	25	SUR/L410	1101	14-16d	6-16d
14"	20/140	SUR/L2.56/14	1204	18-16d	2-10dx1½"
	25	SUR/L414	1123	18-16d	8-16d
16"	20/140	SUR/L2.56/14	1235	18-16d	2-10dx1½"
	25	SUR/L414	1127	18-16d	8-16d
18"	25	SUR/L414	2395	18-16d	8-16d
20"	25	SUR/L414	2395	18-16d	8-16d
22"	25	—	—	—	—
24"	25	—	—	—	—

Field Slope and Skew Joist Hanger

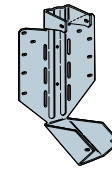

Joist Depth	AJS®	Hanger	LSSU Capacity [lbs]	Nailing	
				Header	Joist
9½"	20/140	LSSUH310	1480	14-16d	2-10dx1½"
	25	LSSU410	1480	14-16d	12-10dx1½"
11⅞"	20/140	LSSUH310	1595	14-16d	2-10dx1½"
	25	LSSU410	1595	14-16d	12-10dx1½"
14"	20/140	LSSUH310	1600	14-16d	2-10dx1½"
	25	LSSU410	1625	14-16d	12-10dx1½"
16"	20/140	—	—	—	—
	25	—	—	—	—
18"	25	—	—	—	—
20"	25	—	—	—	—
22"	25	—	—	—	—
24"	25	—	—	—	—

Adjustable Height Joist Hanger

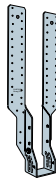

Joist Depth	AJS®	Hanger	THAI Capacity [lbs]	Nailing	
				Header	Joist
9½"	20/140	THAI322	1330	6-10d	2-10dx1½"
	25	THAI422	1330	6-10d	2-10dx1½"
11⅞"	20/140	THAI322	1432	6-10d	2-10dx1½"
	25	THAI422	1432	6-10d	2-10dx1½"
14"	20/140	THAI322	1525	6-10d	2-10dx1½"
	25	THAI422	1525	6-10d	2-10dx1½"
16"	20/140	—	—	—	—
	25	—	—	—	—
18"	25	—	—	—	—
20"	25	—	—	—	—
22"	25	—	—	—	—
24"	25	—	—	—	—

Variable Pitch Joist Connector

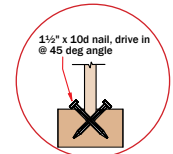
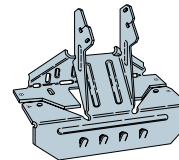

Joist Depth	AJS®	Hanger	Capacity [lbs]	Fastener	
				Top Plate	Rafter
9½"	20/140	VPA3	1006	9-10d	2-10dx1½"
	25	VPA4	1006	11-10d	2-10dx1½"
11⅞"	20/140	VPA3	1020	9-10d	2-10dx1½"
	25	VPA4	1020	11-10d	2-10dx1½"
14"	20/140	VPA3	1032	9-10d	2-10dx1½"
	25	VPA4	1032	11-10d	2-10dx1½"
16"	20/140	VPA3	1048	9-10d	2-10dx1½"
	25	VPA4	1048	11-10d	2-10dx1½"
18"	25	VPA4	1230	11-10d	2-10dx1½"
20"	25	VPA4	1230	11-10d	2-10dx1½"
22"	25	VPA4	1230	11-10d	2-10dx1½"
24"	25	VPA4	1230	11-10d	2-10dx1½"

SIMPSON

Strong-Tie
CONNECTORS

For more information, call
Simpson Strong-Tie
at 1-800-999-5099 or visit
their website at
www.strongtie.com

General Notes

- **Bold Italic hangers require web stiffeners.**
- Capacities will vary with different nailing criteria and/or support conditions; contact supplier or Simpson Strong-Tie for further information.
- Capacity values shown are either hanger capacity values (see support requirements below) or AJS® Joist end reaction capacities — whichever is less.
- All capacity values are downward loads at 100% load duration.
- Use sloped seat hangers and beveled web stiffeners when AJS® Joist slope exceeds ¼" per foot.
- Leave 1/16" clearance (½" maximum) between the end of the supported joist and the head of the hanger.
- At max design capacity shown, hangers may exceed standard ¼" deflection by 1/32".

- For proper installation of the ITT or VPA, the 2-10dx1½" joist nails through the bend tabs must be installed at approximately a 45-degree angle. An alternate fastening method is the installation of a #8x1.25" screw into the joist through the bottom of the hanger.

Support Requirements

- **Support material assumed to be Boise structural composite lumber or sawn lumber (Douglas fir or southern pine species).**
- Minimum support width for single- and double-joist top mount hangers is 3" (1½" for ITT hangers).
- Minimum support width for face mount hangers with 10d and 16d nails is 1½" and 2", respectively.

Single Joist - Top Flange

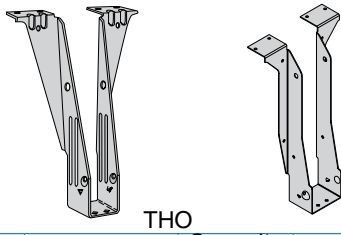

Joist Depth	AJS®	Hanger	Capacity [lbs]	Nailing	
				Header	Joist
9½"	20/140	TFL2595	1006	6-10d	2-10dx1½"
	25	THO35950	1048	10-10d	2-10dx1½"
11⅞"	20/140	TFL25118	1020	6-10d	2-10dx1½"
	25	THO35118	1068	10-10d	2-10dx1½"
14"	20/140	TFL2514	1032	6-10d	2-10dx1½"
	25	THO35140	1086	12-10d	2-10dx1½"
16"	20/140	TFL2516	1048	6-10d	2-10dx1½"
	25	THO35160	1107	12-10d	2-10dx1½"
18"	25	THO35180	2406	14-10d	2-10dx1½"
20"	25	THO35200	2685	14-10d	2-10dx1½"
22"	25	TFI422	2820	10-16d	2-10dx1½"
24"	25	TFI424	2905	10-16d	2-10dx1½"

Single Joist - Face Mount

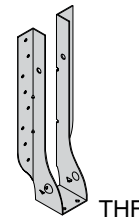

Joist Depth	AJS®	Hanger	Capacity [lbs]	Nailing	
				Header	Joist
9½"	20/140	THF25925	1062	12-10d	2-10dx1½"
	25	THF35925	1062	12-10d	2-10dx1½"
11⅞"	20/140	THF25112	1085	14-10d	2-10dx1½"
	25	THF35112	1085	16-10d	2-10dx1½"
14"	20/140	THF25140	1105	18-10d	2-10dx1½"
	25	THF35140	1105	20-10d	2-10dx1½"
16"	20/140	THF25160	1127	22-10d	2-10dx1½"
	25	THF35157	1127	22-10d	2-10dx1½"
18"	25	THF35165	2430	24-10d	8-10dx1½"
20"	25	THF35165	2735	24-10d	8-10dx1½"
22"	25	THF35165	2785	24-10d	8-10dx1½"
24"	25	THF35165	2785	24-10d	8-10dx1½"

Double Joist - Top Flange

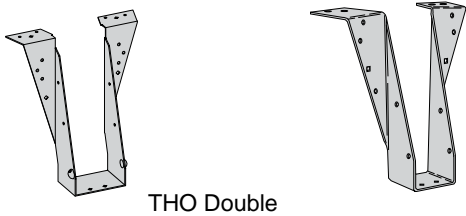

Joist Depth	AJS®	Hanger	Capacity [lbs]	Nailing	
				Header	Joist
9½"	20/140	THO25950-2	2237	10-16d	6-10d
	25	BPH7195	2690	10-16d	6-10d
11⅞"	20/140	THO25118-2	2300	10-16d	6-10d
	25	BPH71118	3060	10-16d	6-10d
14"	20/140	THO25140-2	2355	12-16d	6-10d
	25	BPH7114	3260	10-16d	6-10d
16"	20/140	THO25160-2	2412	12-16d	6-10d
	25	BPH7116	3452	10-16d	6-10d
18"	25	BPH7118	3510	10-16d	6-10d
20"	25	BPH7120	3510	10-16d	6-10d
22"	25	BPH7122	3510	10-16d	6-10d
24"	25	BPH7124	3510	10-16d	6-10d

Double Joist - Face Mount

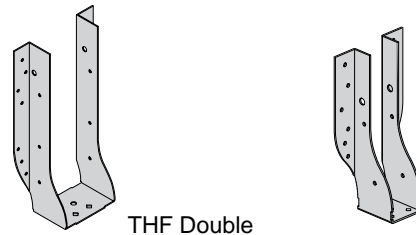

Joist Depth	AJS®	Hanger	Capacity [lbs]	Nailing	
				Header	Joist
9½"	20/140	THF25925-2	1390	12-10d	6-10d
	25	HD7100	1680	12-16d	6-10d
11⅞"	20/140	THF25112-2	1855	16-10d	6-10d
	25	HD7120	2240	16-16d	6-10d
14"	20/140	THF25140-2	2210	20-10d	6-10d
	25	HD7140	2800	20-16d	8-10d
16"	20/140	THF25160-2	2255	24-10d	6-10d
	25	HD7160	3305	24-16d	8-10d
18"	25	HD7180	3920	28-16d	8-10d
20"	25	HD7180	3920	28-16d	8-10d
22"	25	HD7180	3920	28-16d	8-10d
24"	25	HD7180	3920	28-16d	8-10d

Face Mount Skewed 45° Joist Hanger

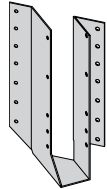

Joist Depth	AJS®	Hanger	SKH Capacity [lbs]	Nailing	
				Header	Joist
9½"	20/140	SKH2520L/R	992	14-10d	10-10dx1½"
	25	SKH410L/R	1062	16-16d	10-16d
11⅞"	20/140	SKH2520L/R	1003	14-10d	10-10dx1½"
	25	SKH410L/R	1085	16-16d	10-16d
14"	20/140	SKH2524L/R	1014	16-10d	10-10dx1½"
	25	SKH414L/R	1105	22-16d	10-16d
16"	20/140	SKH2524L/R	1029	16-10d	10-10dx1½"
	25	SKH414L/R	1127	22-16d	10-16d
18"	25	SKH418L/R	2430	28-16d	10-16d
20"	25	SKH418L/R	2735	28-16d	10-16d
22"	25	SKH418L/R	2820	28-16d	10-16d
24"	25	SKH418L/R	2905	28-16d	10-16d

Field Slope and Skew Joist Hanger

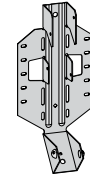

Joist Depth	AJS®	Hanger	LSSH Capacity [lbs]	Nailing	
				Header	Joist
9½"	20/140	LSSH25	1420	14-16d	12-10dx1½"
	25	LSSH35	1420	14-16d	12-10dx1½"
11⅞"	20/140	LSSH25	1530	14-16d	12-10dx1½"
	25	LSSH35	1530	14-16d	12-10dx1½"
14"	20/140	LSSH25	1630	14-16d	12-10dx1½"
	25	LSSH35	1630	14-16d	12-10dx1½"
16"	20/140	LSSH35	1725	14-16d	12-10dx1½"
	25	LSSH35	1725	14-16d	12-10dx1½"
18"	25	LSSH35	1920	14-16d	12-10dx1½"
20"	25	LSSH35	1920	14-16d	12-10dx1½"
22"	25	LSSH35	1920	14-16d	12-10dx1½"
24"	25	LSSH35	1920	14-16d	12-10dx1½"

Adjustable Height Joist Hanger



Joist Depth	AJS®	Hanger	MSH Capacity [lbs]	Nailing	
				Header	Joist
9½"	20/140	—	—	—	—
	25	MSH422	1270	22-10d	4-10d
11⅞"	20/140	MSH318	1367	16-10d	4-10dx1½"
	25	MSH422	1367	22-10d	4-10d
14"	20/140	MSH318	1455	16-10d	4-10dx1½"
	25	—	—	—	—
16"	20/140	MSH318	1413	16-10d	4-10dx1½"
	25	—	—	—	—
18"	25	—	—	—	—
20"	25	—	—	—	—
22"	25	—	—	—	—
24"	25	—	—	—	—

Variable Pitch Joist Connector

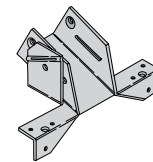

Joist Depth	AJS®	Hanger	TM Capacity [lbs]	Fastener	
				Top Plate	Rafter
9½"	20/140	TMP25	1175	6-10d	4-10dx1½"
	25	TMP4	1175	6-10d	4-10dx1½"
11⅞"	20/140	TMP25	1215	6-10d	4-10dx1½"
	25	TMP4	1215	6-10d	4-10dx1½"
14"	20/140	TMP25	1250	6-10d	4-10dx1½"
	25	TMP4	1250	6-10d	4-10dx1½"
16"	20/140	TMP25	1285	6-10d	4-10dx1½"
	25	TMP4	1285	6-10d	4-10dx1½"
18"	25	TMP4	1970	6-10d	4-10dx1½"
20"	25	TMP4	1970	6-10d	4-10dx1½"
22"	25	TMP4	1970	6-10d	4-10dx1½"
24"	25	TMP4	1970	6-10d	4-10dx1½"



For more information, contact USP Structural Connectors at 1-800-328-5934 or www.uspconnectors.com

General Notes

- **Bold Italic hangers required web stiffeners.**
- Capacities will vary with different nailing criteria and/or support conditions: contact supplier or USP Structural Connectors for further information.
- Capacity values shown are either hanger capacity values (see support requirements below) or AJS® Joist end reaction capacities — whichever is less.
- All capacity values are downward loads at 100% load duration.
- Use sloped seat hangers and beveled web stiffeners when AJS® Joist slope exceeds ¼" per foot.

- Leave 1/16" clearance (¼" maximum) between the end of the supported joist and the head of the hanger.
- For AJS® Joist applications, consult USP for capacity reduction.

Support Requirements

- **Support material assumed to be Boise structural composite lumber or sawn lumber (Douglas fir or southern pine species).**
- Minimum support width for single- and double-joist top mount hangers is 3": (1½" for THO hangers).
- Minimum support width for face mount hangers with 10d and 16d nails is 1¼" and 2", respectively.

ALLJoist®

Boise Cascade has a proven track record of providing quality wood products and a nationwide building materials distribution network for our customers, helping them to enhance their own businesses.

Boise Engineered Wood Products build better homes with stronger, stiffer floors using only wood purchased in compliance with Sustainable Forestry Initiative (SFI) programs. Take a moment to view our green brochure at http://www.bc.com/wood/ewp/Boise_EWP_Green.html.

Lifetime Guaranteed Quality and Performance

Boise Cascade warrants its BCI® Joist, VERSA-LAM®, and ALLJOIST® products to comply with our specifications, to be free from defects in material and workmanship, and to meet or exceed our performance specifications for the normal and expected life of the structure when correctly stored, installed and used according to our Installation Guide.

BOISE CASCADE IS CERTIFIED BY SFI, AMERICA'S LEADING FORESTRY CERTIFICATION PROGRAM:

Boise Cascade doesn't own forests, but buys wood fiber in compliance with SFI, the Sustainable Forestry Initiative®, which certifies the dominant share of North American forest acreage -- 160+ million acres. Boise Cascade is an SFI chain-of-custody certified national supplier. Chain-of-custody tracks and records possession and transfer of wood fiber from forest of origin through all stages of distribution and production to the homebuilder. Chain-of-custody assures that Boise Cascade products are made using fiber from responsibly-managed forests and not from areas that are illegally harvested, major tropical wilderness areas or biodiversity hotspots. Boise Cascade's computerized chain-of-custody system documents sourcing of all wood fiber purchased, ensuring that none gets into Boise Cascade inventory unless it comes from acceptable sources.



If in doubt ask! For the number of the closest Boise EWP distributor/support center, call **1-800-232-0788**



BCI, BC CALC, BC COLUMN, BC FRAMER, BC RIM BOARD, BOISE GLULAM, SIMPLE FRAMING SYSTEM, VERSA-LAM, VERSA-RIM, and VERSA-STUD are trademarks of Boise Cascade, L.L.C. or its affiliates.

The information in this document pertains to use in the UNITED STATES ONLY, Allowable Stress Design. Refer to the ALLJOIST Specifier Guide Canada for use in Canada, Limit States Design.

Your Dealer is:

If no dealer is listed, call 1-800-232-0788

For information about Boise Engineered Wood Products, including sales terms and conditions, warranties and disclaimers,

visit our website at www.BC.com/ewp



Boise Cascade
Engineered Wood Products

Great products are only the beginning.™