

BCI® Rafters

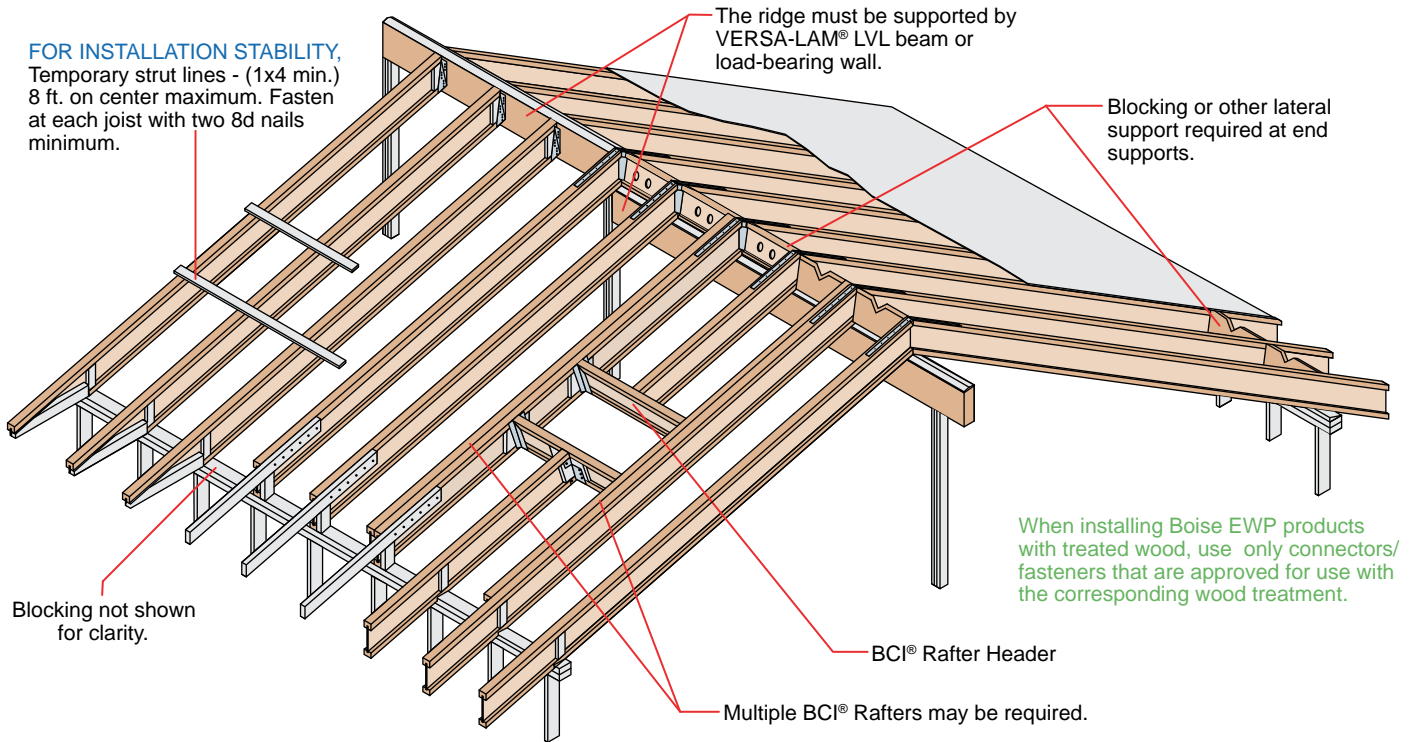

SAFETY WARNING

DO NOT ALLOW WORKERS ON BCI® JOISTS UNTIL ALL HANGERS, BCI® RIM JOISTS, RIM BOARDS, BCI® BLOCKING PANELS, X-BRACING AND TEMPORARY 1x4 STRUT LINES ARE INSTALLED AS SPECIFIED BELOW.

SERIOUS ACCIDENTS CAN RESULT FROM INSUFFICIENT ATTENTION TO PROPER BRACING DURING CONSTRUCTION. ACCIDENTS CAN BE AVOIDED UNDER NORMAL CONDITIONS BY FOLLOWING THESE GUIDELINES:

- Build a braced end wall at the end of the bay, or permanently install the first eight feet of BCI® Joists and the first course of sheathing. As an alternate, temporary sheathing may be nailed to the first four feet of BCI® Joists at the end of the bay.
- All hangers, BCI® rim joists, rim boards, BCI® blocking panels, and x-bracing must be completely installed and properly nailed as each BCI® Joist is set.
- Install temporary 1x4 strut lines at no more than eight feet on center as additional BCI® Joists are set. Nail the strut lines to the sheathed area, or braced end wall, and to each BCI® Joist with two 8d nails.
- The ends of cantilevers must be temporarily secured by strut lines on both the top and bottom flanges.
- Straighten the BCI® Joists to within 1/2 inch of true alignment before attaching strut lines and sheathing.
- Remove the temporary strut lines only as required to install the permanent sheathing.
- Failure to install temporary bracing may result in sideways buckling or roll-over under light construction loads.

BCI® Ceiling Joist with Bevel End Cut (For Limited-Access Attics Only)

BCI® Joist shall not be used as collar/tension tie.

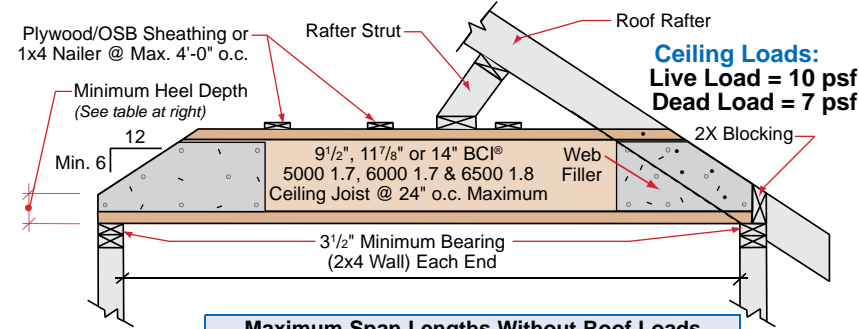

Ceiling Loads:
Live Load = 10 psf
Dead Load = 7 psf

Maximum Span Lengths Without Roof Loads	
9 1/2" BCI® 5000 1.7 / 6000 1.7 / 6500 1.8	20'-0"
11 7/8" BCI® 5000 1.7 / 6000 1.7 / 6500 1.8	22'-6"
14" BCI® 6000 1.7 / 6500 1.8	25'-0"

(If roof loads present, see Notes 2 & 3 at right)

Minimum Heel Depths	Joist Depth	End Wall	
		2 x 4	2 x 6
9 1/2"	9 1/2"	2 1/2"	1 1/2"
11 7/8"	11 7/8"	3 1/2"	2 1/2"
14"	14"	4 1/2"	3 1/2"

Notes:

- 1) Detail is to be used only for ceiling joists with no access to attic space.
- 2) Ceiling joist must be designed to carry all roof load transferred through rafter struts as shown.
- 3) BCI® ceiling joist end reaction may not exceed 550 pounds.
- 4) Minimum roof slope is 6/12.
- 5) Nail roof rafter to BCI® top flange with 1-16d sinker or box nail.
- 6) 1x4 nailers must be continuous and nailed to a braced end wall.
- 7) Install a web stiffener on each side of BCI® Joist at beveled ends. Nail roof rafter to BCI® Joist per building code requirements for ceiling joist to roof rafter connection.

Additional roof framing details available with BC FRAMER® software (see page 33)

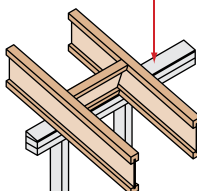
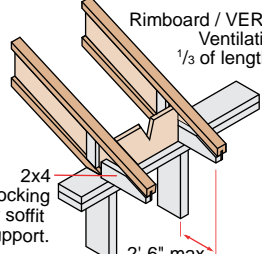
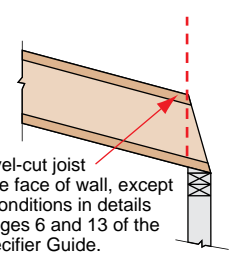
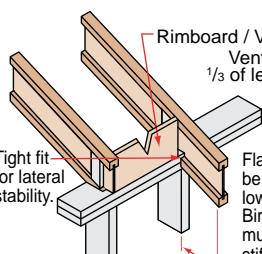
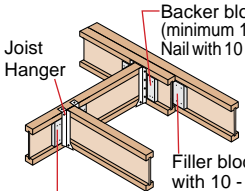
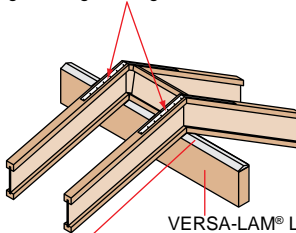
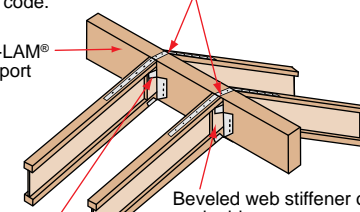
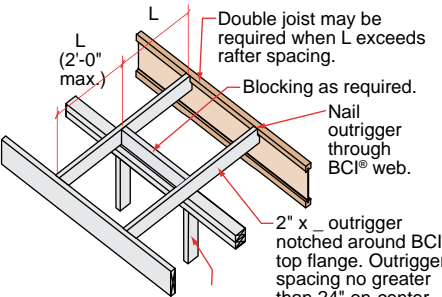
<p>2x beveled plate for slope greater than 1/4/12.</p>  <p>Simpson VPA or USP TMP connectors or equal can be used in lieu of beveled plate for slopes from 3/12 to 12/12.</p>	<p>10d nails at 6" o.c.</p> <p>2x4 one side for 135 PLF max. 2x6 one side for 240 PLF max.</p> <p>Backer block. Thickness per corresponding BCI® series.</p> <p>2x block</p> <p>BCI® blocking Holes cut for ventilation.</p> <p>4'-0" horiz.</p> <p>2'-6" horiz.</p>	<p>Rimboard / VERSA-LAM® blocking. Ventilation "V" cut: 1/3 of length, 1/2 of depth</p>  <p>2x4 blocking for soffit support.</p> <p>2'-6" max.</p> <p>Flange of BCI® Joists may be birdsmouth cut only at the low end of the joist. Birds-mouth cut BCI® joist must bear fully on plate, web stiffener required each side. Bottom flange shall be fully supported.</p>
<p>DO NOT bevel-cut joist beyond inside face of wall, except for specific conditions in details shown on pages 6 and 13 of the Western Specifier Guide.</p> 	<p>Rimboard / VERSA-LAM® blocking. Ventilation "V" cut: 1/3 of length, 1/2 of depth</p>  <p>Tight fit for lateral stability.</p> <p>2'-6" max.</p> <p>Flange of BCI® Joists may be birdsmouth cut only at the low end of the joist. Birds-mouth cut BCI® Joist must bear fully on plate, web stiffener required each side.</p>	<p>Backer block (minimum 12" wide). Nail with 10 - 10d nails.</p>  <p>Joist Hanger</p> <p>Filler block. Nail with 10 - 10d nails.</p> <p>Backer block required where top flange joist hanger load exceeds 250 lbs. Install tight to top flange.</p>
<p>Simpson or USP LSTA24 strap, nailing per governing building code.</p>  <p>Double-beveled wood plate.</p> <p>VERSA-LAM® LVL support beam.</p>	<p>Simpson or USP LSTA24 strap where slope exceeds 7/12 (straps may be required for lower slopes in high-wind areas). Nailing per governing building code.</p> <p>VERSA-LAM® LVL support beam.</p>  <p>Beveled web stiffener on each side.</p> <p>Simpson LSSUI or USP TMU hanger.</p>	<p>Double joist may be required when L exceeds rafter spacing.</p> <p>Blocking as required.</p> <p>Nail outrigger through BCI® web.</p> <p>2" x _ outrigger notched around BCI® top flange. Outrigger spacing no greater than 24" on-center.</p> <p>End Wall.</p> <p>L (2'-0" max.)</p> 

LATERAL SUPPORT

- BCI® Joists must be laterally supported at end supports (including supports adjacent to overhangs) with hangers, rimboard, or blocking (VERSA-LAM®, Boise Rimboard or BCI® Joist). Metal cross bracing or other x-bracing provides adequate lateral support for BCI® Joists, consult governing building code for roof diaphragm connection provisions.

MINIMUM BEARING LENGTH FOR BCI® JOISTS

- 13/4 inches is required at end supports. 3 1/2 inches is required at cantilever and intermediate supports.
- Longer bearing lengths allow higher reaction values. Refer to the building code evaluation report or the BC CALC® software.

NAILING REQUIREMENTS

- BCI® rim joist, rim board or closure panel to BCI® joist:
 - Rims or closure panel 1 3/4 inches thick and less: 2-8d nails, one each in the top and bottom flange.
 - BCI® 5000 rim joist: 2-10d box nails, one each in the top and bottom flange.
 - BCI® 6000, 60 rim joist: 2-16d box nails, one each in the top and bottom flange.
 - BCI® 6500, 90 rim joist: Toe-nail top flange to rim joist with 2-10d box nails, one each side of flange.
- BCI® rim joist, rim board or BCI® blocking panel to support:
 - 8d nails at 6 inches on center.
 - When used for shear transfer, follow the building designer's specification.
- BCI® joist to support:
 - 2-8d nails, one on each side of the web, placed 1 1/2 inches minimum from the end of the BCI® Joist to limit splitting.

- Sheathing to BCI® joist:
 - See *Closest Allowable Nail Spacing* on page 24.
 - BCI® 5000 joist: Maximum nail spacing is 18 inches on center.
 - BCI® 6000, 6500, 60, 90 joist: Maximum nail spacing is 24 inches on center.
 - 14 gauge staples may be substituted for 8d nails if the staples penetrate at least 1 inch into the joist.
 - Wood screws may be acceptable, contact local building official and/or Boise EWPP Engineering for further information.

BACKER AND FILLER BLOCK DIMENSIONS

Series	Backer Block Thickness	Filler Block Thickness
5000 1.7	3/4" or 7/8" wood panels	Two 3/4" wood panels or 2 x _
6000 1.7	1 1/8" or two 1/2" wood panels	2 x _ + 3/8" or 3/4" wood panel
6500 1.8	1 1/8" or two 1/2" wood panels	2 x _ + 5/8" or 3/4" wood panel
60 2.0	1 1/8" or two 1/2" wood panels	2 x _ + 5/8" or 3/4" wood panel
90 2.0	2 x _ lumber	Double 2 x _ lumber

- Cut backer and filler blocks to a maximum depth equal to the web depth minus 1/4" to avoid a forced fit.

WEB STIFFENER REQUIREMENTS

- See *Web Stiffener Requirements* on page 9.

PROTECT BCI® JOISTS FROM THE WEATHER

- BCI® Joists are intended only for applications that provide permanent protection from the weather. Bundles of BCI® Joists should be covered and stored off of the ground on stickers.

MAXIMUM SLOPE

- Unless otherwise noted, all roof details are valid for slopes of 12 in 12 or less.

VENTILATION

- The 1 1/2 inch, pre-stamped knock-out holes spaced at 12 inches on center along the BCI® Joist may all be knocked out and used for cross ventilation. Consult a ventilation expert for specific requirements.

BIRDSMOUTH CUTS

- BCI® Joists may be birdsmouth cut only at the low end support. BCI® joists with birdsmouth cuts may cantilever up to 2'-6" past the low end support. The bottom flange must sit fully on the support and may not overhang the inside face of the support. High end supports and intermediate supports may not be birdsmouth cut.

Roof Span Tables

Maximum clear span in feet and inches, based on horizontal spans.

		115% and 125% Load Duration																						
		BCI® 5000 1.7 Series 2" Flange Width										BCI® 6000 1.7 Series 2 ⁵ / ₁₆ " Flange Width												
		9 ¹ / ₂ " BCI® 5000 1.7			11 ⁷ / ₈ " BCI® 5000 1.7			14" BCI® 5000 1.7			9 ¹ / ₂ " BCI® 6000 1.7			11 ⁷ / ₈ " BCI® 6000 1.7			14" BCI® 6000 1.7			16" BCI® 6000 1.7				
		Live Load [psf]	Dead Load [psf]	4/12 or Less	4/12 to 8/12	8/12 to 12/12	4/12 or Less	4/12 to 8/12	8/12 to 12/12	4/12 or Less	4/12 to 8/12	8/12 to 12/12	4/12 or Less	4/12 to 8/12	8/12 to 12/12	4/12 or Less	4/12 to 8/12	8/12 to 12/12	4/12 or Less	4/12 to 8/12	8/12 to 12/12	4/12 or Less	4/12 to 8/12	8/12 to 12/12
12" o.c.	Non-Snow 125%	20	10	24'-1"	22'-9"	21'-1"	28'-7"	26'-11"	25'-0"	32'-7"	30'-8"	28'-6"	25'-1"	23'-8"	21'-11"	29'-11"	28'-3"	26'-2"	34'-0"	32'-1"	29'-9"	37'-9"	35'-7"	33'-0"
		20	15	22'-10"	21'-5"	19'-9"	27'-1"	25'-5"	23'-5"	30'-10"	29'-0"	26'-9"	23'-9"	22'-4"	20'-7"	28'-4"	26'-7"	24'-7"	32'-3"	30'-3"	27'-11"	35'-9"	33'-7"	30'-11"
		20	20	21'-9"	20'-5"	18'-9"	25'-10"	24'-2"	22'-3"	29'-5"	27'-7"	25'-4"	22'-8"	21'-2"	19'-6"	27'-1"	25'-4"	23'-3"	30'-9"	28'-9"	26'-5"	34'-1"	31'-11"	29'-4"
	Snow 115%	25	10	22'-11"	21'-8"	20'-2"	27'-2"	25'-8"	23'-10"	30'-10"	29'-3"	27'-2"	23'-10"	22'-6"	20'-11"	28'-5"	26'-10"	25'-0"	32'-4"	30'-6"	28'-5"	35'-7"	33'-10"	31'-6"
		25	15	21'-10"	20'-7"	19'-0"	25'-10"	24'-4"	22'-7"	28'-9"	27'-9"	25'-8"	22'-8"	21'-5"	19'-9"	27'-1"	25'-6"	23'-8"	30'-10"	29'-0"	26'-10"	33'-2"	32'-2"	29'-9"
		30	10	21'-11"	20'-9"	19'-4"	25'-11"	24'-7"	22'-11"	28'-10"	28'-0"	26'-1"	22'-9"	21'-7"	20'-1"	27'-2"	25'-9"	24'-0"	30'-11"	29'-3"	27'-3"	33'-4"	32'-5"	30'-3"
		30	15	21'-0"	19'-10"	18'-4"	24'-10"	23'-5"	21'-9"	27'-2"	26'-6"	24'-10"	21'-10"	20'-7"	19'-1"	26'-1"	24'-7"	22'-10"	29'-4"	27'-11"	25'-11"	31'-4"	30'-7"	28'-9"
		40	10	19'-11"	19'-1"	18'-0"	23'-7"	22'-8"	21'-4"	25'-10"	25'-5"	24'-4"	20'-9"	19'-10"	18'-9"	24'-9"	23'-9"	22'-5"	27'-11"	27'-0"	25'-5"	29'-10"	29'-4"	28'-3"
		40	15	19'-7"	18'-7"	17'-3"	22'-6"	22'-0"	20'-6"	24'-7"	24'-1"	23'-4"	20'-5"	19'-3"	18'-0"	24'-4"	23'-0"	21'-6"	26'-6"	26'-0"	24'-5"	28'-4"	27'-10"	27'-1"
		50	10	18'-5"	17'-8"	16'-9"	21'-7"	20'-11"	19'-11"	23'-7"	23'-3"	22'-8"	19'-2"	18'-5"	17'-5"	22'-11"	22'-0"	20'-10"	25'-5"	25'-0"	23'-8"	27'-2"	26'-11"	26'-3"
50	15	18'-3"	17'-7"	16'-5"	20'-9"	20'-5"	19'-5"	22'-7"	22'-3"	21'-8"	19'-2"	18'-3"	17'-1"	22'-5"	21'-10"	20'-5"	24'-5"	24'-0"	23'-2"	26'-1"	25'-8"	25'-1"		
16" o.c.	Non-Snow 125%	20	10	21'-10"	20'-7"	19'-1"	25'-11"	24'-5"	22'-8"	29'-6"	27'-10"	25'-10"	22'-9"	21'-5"	19'-11"	27'-2"	25'-7"	23'-9"	30'-10"	29'-1"	27'-0"	34'-2"	32'-3"	29'-11"
		20	15	20'-8"	19'-5"	17'-11"	24'-6"	23'-0"	21'-3"	27'-8"	26'-3"	24'-3"	21'-6"	20'-2"	18'-8"	25'-8"	24'-2"	22'-3"	29'-3"	27'-5"	25'-4"	32'-0"	30'-5"	28'-1"
		20	20	19'-9"	18'-6"	17'-0"	23'-5"	21'-11"	20'-2"	25'-10"	25'-0"	22'-11"	20'-6"	19'-3"	17'-8"	24'-6"	22'-11"	21'-1"	27'-10"	26'-1"	24'-0"	29'-10"	28'-10"	26'-7"
	Snow 115%	25	10	20'-9"	19'-7"	18'-3"	24'-6"	23'-3"	21'-8"	26'-8"	26'-1"	24'-8"	21'-7"	20'-5"	19'-0"	25'-9"	24'-4"	22'-8"	28'-10"	27'-8"	25'-9"	30'-9"	30'-2"	28'-7"
		25	15	19'-9"	18'-7"	17'-3"	22'-10"	22'-1"	20'-5"	24'-10"	24'-3"	23'-4"	20'-7"	19'-4"	17'-11"	24'-7"	23'-1"	21'-5"	26'-10"	26'-2"	24'-4"	28'-9"	27'-11"	27'-0"
		30	10	19'-10"	18'-9"	17'-6"	22'-11"	22'-3"	20'-9"	24'-11"	24'-6"	23'-8"	20'-7"	19'-6"	18'-3"	24'-7"	23'-4"	21'-9"	26'-11"	26'-6"	24'-9"	28'-10"	28'-4"	27'-5"
		30	15	19'-0"	17'-11"	16'-8"	21'-6"	21'-0"	19'-9"	23'-5"	22'-11"	22'-2"	19'-9"	18'-8"	17'-4"	23'-3"	22'-3"	20'-8"	25'-4"	24'-9"	23'-6"	27'-1"	26'-5"	25'-7"
		40	10	18'-0"	17'-4"	16'-4"	20'-6"	20'-2"	19'-4"	22'-4"	22'-0"	21'-7"	18'-9"	18'-0"	17'-0"	22'-1"	21'-6"	20'-3"	24'-1"	23'-9"	23'-1"	25'-9"	25'-5"	24'-11"
		40	15	17'-2"	16'-10"	15'-8"	19'-6"	19'-1"	18'-7"	21'-3"	20'-10"	20'-3"	18'-5"	17'-6"	16'-3"	21'-0"	20'-8"	19'-5"	22'-11"	22'-6"	21'-11"	24'-6"	24'-0"	23'-5"
		50	10	16'-6"	16'-0"	15'-2"	18'-8"	18'-6"	18'-0"	20'-4"	20'-1"	19'-9"	17'-4"	16'-8"	15'-10"	20'-2"	19'-11"	18'-11"	22'-0"	21'-9"	21'-4"	23'-6"	23'-3"	22'-10"
50	15	15'-10"	15'-6"	14'-10"	17'-11"	17'-7"	17'-3"	19'-6"	19'-2"	18'-9"	17'-1"	16'-6"	15'-5"	19'-4"	19'-0"	18'-5"	21'-1"	20'-9"	20'-3"	22'-7"	22'-2"	21'-8"		
19.2" o.c.	Non-Snow 125%	20	10	20'-6"	19'-4"	18'-0"	24'-4"	22'-11"	21'-4"	27'-5"	26'-2"	24'-3"	21'-4"	20'-2"	18'-8"	25'-6"	24'-0"	22'-4"	29'-0"	27'-4"	25'-4"	31'-7"	30'-4"	28'-2"
		20	15	19'-5"	18'-3"	16'-10"	23'-0"	21'-8"	20'-0"	25'-3"	24'-6"	22'-9"	20'-2"	19'-0"	17'-6"	24'-1"	22'-8"	20'-11"	27'-4"	25'-9"	23'-9"	29'-2"	28'-4"	26'-5"
		20	20	18'-6"	17'-4"	15'-11"	21'-8"	20'-7"	18'-11"	23'-7"	22'-9"	21'-7"	19'-3"	18'-0"	16'-7"	23'-0"	21'-7"	19'-10"	25'-6"	24'-6"	22'-6"	27'-3"	26'-3"	25'-0"
	Snow 115%	25	10	19'-6"	18'-5"	17'-2"	22'-4"	21'-10"	20'-4"	24'-4"	23'-10"	23'-2"	20'-3"	19'-2"	17'-10"	24'-1"	22'-10"	21'-4"	26'-3"	25'-9"	24'-3"	28'-1"	27'-6"	26'-9"
		25	15	18'-4"	17'-6"	16'-2"	20'-10"	20'-3"	19'-2"	22'-8"	22'-1"	21'-4"	19'-4"	18'-2"	16'-10"	22'-6"	21'-9"	20'-1"	24'-6"	23'-10"	22'-11"	26'-2"	25'-6"	24'-7"
		30	10	18'-5"	17'-8"	16'-5"	20'-11"	20'-6"	19'-6"	22'-9"	22'-4"	21'-10"	19'-4"	18'-4"	17'-1"	22'-7"	21'-11"	20'-5"	24'-7"	24'-2"	23'-3"	26'-3"	25'-10"	25'-2"
		30	15	17'-4"	16'-10"	15'-8"	19'-7"	19'-2"	18'-6"	21'-5"	20'-11"	20'-3"	18'-7"	17'-6"	16'-3"	21'-2"	20'-8"	19'-5"	23'-1"	22'-7"	21'-10"	24'-8"	24'-1"	23'-4"
		40	10	16'-6"	16'-3"	15'-4"	18'-8"	18'-5"	18'-0"	20'-4"	20'-1"	19'-8"	17'-7"	16'-11"	15'-11"	20'-2"	19'-11"	19'-1"	22'-0"	21'-8"	21'-3"	23'-6"	23'-2"	22'-8"
		40	15	15'-8"	15'-4"	14'-8"	17'-9"	17'-5"	16'-11"	19'-4"	19'-0"	18'-6"	16'-11"	16'-5"	15'-3"	19'-2"	18'-10"	18'-3"	20'-11"	20'-6"	19'-11"	22'-4"	21'-11"	21'-4"
		50	10	15'-0"	14'-10"	14'-3"	17'-0"	16'-10"	16'-7"	18'-7"	18'-4"	18'-0"	16'-3"	15'-7"	14'-10"	18'-5"	18'-2"	17'-9"	20'-1"	19'-10"	19'-6"	21'-5"	21'-2"	20'-10"
50	15	14'-5"	14'-2"	13'-10"	16'-4"	16'-1"	15'-8"	17'-10"	17'-6"	17'-1"	15'-7"	15'-4"	14'-6"	17'-8"	17'-4"	16'-11"	19'-3"	18'-11"	18'-6"	20'-7"	20'-3"	19'-9"		
24" o.c.	Non-Snow 125%	20	10	19'-0"	17'-11"	16'-8"	22'-5"	21'-3"	19'-9"	24'-6"	23'-11"	22'-6"	19'-9"	18'-8"	17'-4"	23'-7"	22'-3"	20'-8"	26'-5"	25'-4"	23'-6"	28'-3"	27'-7"	26'-1"
		20	15	18'-0"	16'-11"	15'-7"	20'-9"	20'-0"	18'-6"	22'-7"	21'-11"	21'-0"	18'-8"	17'-7"	16'-3"	22'-4"	21'-0"	19'-5"	24'-5"	23'-8"	22'-0"	26'-1"	25'-3"	24'-3"
		20	20	17'-1"	16'-1"	14'-9"	19'-4"	18'-8"	17'-6"	21'-1"	20'-4"	19'-5"	17'-10"	16'-8"	15'-4"	20'-10"	19'-11"	18'-4"	22'-9"	22'-0"	20'-10"	24'-4"	23'-6"	22'-5"
	Snow 115%	25	10	17'-7"	17'-1"	15'-11"	19'-11"	19'-6"	18'-10"	21'-9"	21'-3"	20'-8"	18'-9"	17'-9"	16'-6"	21'-6"	21'-1"	19'-9"	23'-6"	23'-0"	22'-4"	25'-1"	24'-7"	23'-11"
		25	15	16'-5"	15'-11"	15'-0"	18'-7"	18'-1"	17'-5"	20'-3"	19'-9"	19'-0"	17'-9"	16'-10"	15'-7"	20'-1"	19'-7"	18'-8"	21'-11"	21'-4"	20'-7"	23'-5"	22'-9"	22'-0"
		30	10	16'-5"	16'-2"	15'-3"	18'-8"	18'-4"	17'-10"	20'-4"	20'-0"	19'-6"	17'-9"	17'-0"	15'-10"	20'-2"	19'-9"	18'-11"	21'-11"	21'-7"	21'-0"	23'-6"	23'-1"	22'-6"
		30	15	15'-5"	15'-1"	14'-6"	17'-6"	17'-1"	16'-7"	19'-1"	18'-8"	18'-1"	16'-8"	16'-2"	15'-1"	18'-11"	18'-6"	17'-11"	20'-8"	20'-2"	19'-6"	22'-1"	21'-7"	20'-10"
		40	10	14'-8"	14'-6"	14'-2"	16'-8"	16'-5"	16'-1"	18'-2"	17'-11"	17'-7"	15'-11"	15'-7"	14'-9"	18'-0"	17'-9"	17'-5"	19'-8"	19'-4"	19'-0"	21'-0"	20'-8"	20'-3"
		40	15	14'-0"	13'-8"	13'-4"	15'-10"	15'-7"	15'-2"	17'-3"	16'-11"	16'-6"	15'-1"	14'-10"	14'-2"	17'-2"	16'-10"	16'-4"	18'-8"	18'-4"	17'-10"	20'-0"	19'-7"	19'-1"
		50	10	13'-5"	13'-3"	13'-0"	15'-3"	15'-0"	14'-9"	16'-7"	16'-5"	16'-1"	14'-6"	14'-4"	13'-9"	16'-5"	16'-3"	16'-0"	17'-11"	17'-8"	17'-5"	19'-2"	18'-11"	18'-7"
50	15	12'-10"	12'-8"	12'-4"	14'-7"	14'-4"	14'-0"	15'-11"	15'-8"	14'-11"	13'-11"	13'-8"	13'-4"	15'-9"	15'-6"	15'-2"	17'-2"	16'-11"	16'-6"	18'-3"	17'-8"	16'-10"		

- Table values are limited by shear, moment, total load deflection equal to L/180 and live load deflection equal to L/240. Check the local building code for other deflection limits that may apply.
- Table values represent the most restrictive of simple or multiple span applications.
- Table values assume minimum bearing lengths without web stiffeners for joist depths of 16 inches and less. 18 and 20 inch joists require web stiffeners.
- This table was designed to apply to a broad range of applications. It may be possible to exceed the limitations of this table by analyzing a specific application with the BC CALC® software.
- Slope roof joists at least ¼" over 12" to minimize ponding.
- Allowable spans and loads shall be adjusted and checked for wind load as required by local building code.

Roof Span Tables

Maximum clear span in feet and inches, based on horizontal spans.

115% and 125% Load Duration

			BCI® 6500 1.8 Series 2 ⁹ / ₁₆ " Flange Width												
			9 ¹ / ₂ " BCI® 6500 1.8			11 ⁷ / ₈ " BCI® 6500 1.8			14" BCI® 6500 1.8			16" BCI® 6500 1.8			
			4/12 or Less	4/12 to 8/12	8/12 to 12/12	4/12 or Less	4/12 to 8/12	8/12 to 12/12	4/12 or Less	4/12 to 8/12	8/12 to 12/12	4/12 or Less	4/12 to 8/12	8/12 to 12/12	
Clear Span	Load Type	Live Load [psf]	Dead Load [psf]	Span (ft-in)											
		12" o.c.	Non-Snow 125%	20	10	26'-5"	24'-11"	23'-1"	31'-5"	29'-7"	27'-5"	35'-9"	33'-8"	31'-3"	39'-6"
12" o.c.	Snow 115%	25	10	25'-1"	23'-8"	22'-1"	29'-10"	28'-2"	26'-2"	33'-11"	32'-1"	29'-10"	37'-6"	35'-5"	33'-0"
		25	15	23'-11"	22'-6"	20'-10"	28'-5"	26'-9"	24'-9"	32'-4"	30'-5"	28'-2"	35'-9"	33'-8"	31'-2"
		30	10	23'-11"	22'-8"	21'-2"	28'-6"	27'-0"	25'-2"	32'-5"	30'-8"	28'-8"	35'-10"	33'-11"	31'-8"
		30	15	23'-0"	21'-8"	20'-1"	27'-4"	25'-9"	23'-11"	31'-1"	29'-4"	27'-3"	34'-5"	32'-5"	30'-1"
		40	10	21'-10"	20'-11"	19'-9"	25'-11"	24'-10"	23'-6"	29'-6"	28'-4"	26'-9"	32'-8"	31'-4"	29'-7"
		40	15	21'-5"	20'-4"	18'-11"	25'-6"	24'-2"	22'-6"	29'-1"	27'-6"	25'-7"	31'-5"	30'-5"	28'-4"
		50	10	20'-2"	19'-4"	18'-4"	24'-0"	23'-0"	21'-10"	27'-4"	26'-3"	24'-11"	30'-2"	29'-0"	27'-6"
		50	15	20'-2"	19'-3"	18'-0"	24'-0"	22'-10"	21'-4"	27'-0"	26'-0"	24'-4"	28'-11"	28'-5"	26'-11"
16" o.c.	Non-Snow 125%	20	10	23'-11"	22'-7"	20'-11"	28'-5"	26'-10"	24'-11"	32'-5"	30'-6"	28'-4"	35'-10"	33'-9"	31'-4"
		20	15	22'-8"	21'-3"	19'-8"	26'-11"	25'-4"	23'-4"	30'-8"	28'-10"	26'-7"	33'-11"	31'-10"	29'-5"
		20	20	21'-7"	20'-3"	18'-7"	25'-8"	24'-1"	22'-1"	29'-3"	27'-5"	25'-2"	32'-4"	30'-3"	27'-10"
	Snow 115%	25	10	22'-8"	21'-6"	20'-0"	27'-0"	25'-6"	23'-9"	30'-9"	29'-1"	27'-1"	34'-0"	32'-2"	29'-11"
		25	15	21'-8"	20'-5"	18'-11"	25'-9"	24'-3"	22'-5"	29'-4"	27'-7"	25'-7"	31'-10"	30'-6"	28'-3"
		30	10	21'-8"	20'-7"	19'-2"	25'-10"	24'-5"	22'-10"	29'-5"	27'-10"	26'-0"	31'-11"	30'-9"	28'-9"
		30	15	20'-10"	19'-8"	18'-3"	24'-9"	23'-4"	21'-8"	28'-1"	26'-7"	24'-8"	30'-0"	29'-4"	27'-4"
		40	10	19'-9"	18'-11"	17'-10"	23'-6"	22'-6"	21'-3"	26'-9"	25'-8"	24'-3"	28'-7"	28'-2"	26'-9"
Snow 115%	40	15	19'-5"	18'-5"	17'-2"	23'-1"	21'-11"	20'-5"	25'-5"	24'-11"	23'-3"	27'-2"	26'-8"	25'-8"	
	50	10	18'-3"	17'-6"	16'-8"	21'-9"	20'-10"	19'-10"	24'-5"	23'-9"	22'-7"	26'-1"	25'-9"	24'-11"	
	50	15	18'-3"	17'-5"	16'-3"	21'-5"	20'-9"	19'-4"	23'-5"	23'-0"	22'-0"	25'-0"	24'-7"	24'-0"	
	19.2" o.c.	Non-Snow 125%	20	10	22'-6"	21'-2"	19'-8"	26'-9"	25'-2"	23'-5"	30'-5"	28'-8"	26'-8"	33'-8"	31'-9"
20			15	21'-3"	20'-0"	18'-5"	25'-4"	23'-9"	21'-11"	28'-10"	27'-1"	25'-0"	31'-10"	29'-11"	27'-7"
20			20	20'-3"	19'-0"	17'-6"	24'-2"	22'-7"	20'-9"	27'-6"	25'-9"	23'-8"	30'-2"	28'-5"	26'-2"
Snow 115%		25	10	21'-4"	20'-2"	18'-9"	25'-4"	24'-0"	22'-4"	28'-11"	27'-4"	25'-5"	31'-1"	30'-2"	28'-1"
		25	15	20'-4"	19'-2"	17'-9"	24'-2"	22'-9"	21'-1"	27'-2"	25'-11"	24'-0"	29'-0"	28'-3"	26'-7"
		30	10	20'-4"	19'-4"	18'-0"	24'-3"	23'-0"	21'-5"	27'-3"	26'-2"	24'-5"	29'-1"	28'-7"	27'-0"
		30	15	19'-6"	18'-5"	17'-1"	23'-3"	21'-11"	20'-4"	25'-7"	25'-0"	23'-2"	27'-5"	26'-9"	25'-8"
		40	10	18'-6"	17'-9"	16'-9"	22'-1"	21'-2"	20'-0"	24'-4"	24'-0"	22'-9"	26'-1"	25'-8"	25'-2"
Snow 115%	40	15	18'-3"	17'-3"	16'-1"	21'-3"	20'-7"	19'-2"	23'-2"	22'-9"	21'-10"	24'-9"	24'-4"	23'-8"	
	50	10	17'-1"	16'-5"	15'-7"	20'-5"	19'-7"	18'-7"	22'-3"	22'-0"	21'-2"	23'-9"	23'-6"	23'-1"	
	50	15	17'-1"	16'-4"	15'-3"	19'-7"	19'-3"	18'-2"	21'-4"	21'-0"	20'-6"	22'-10"	22'-2"	21'-2"	
	24" o.c.	Non-Snow 125%	20	10	20'-10"	19'-8"	18'-3"	24'-9"	23'-4"	21'-8"	28'-2"	26'-7"	24'-8"	31'-2"	29'-5"
20			15	19'-8"	18'-6"	17'-1"	23'-5"	22'-0"	20'-4"	26'-8"	25'-1"	23'-2"	28'-11"	27'-9"	25'-7"
20			20	18'-9"	17'-7"	16'-2"	22'-4"	20'-11"	19'-3"	25'-3"	23'-10"	21'-11"	26'-11"	26'-0"	24'-3"
Snow 115%		25	10	19'-9"	18'-8"	17'-5"	23'-6"	22'-3"	20'-8"	26'-0"	25'-4"	23'-7"	27'-10"	27'-3"	26'-1"
		25	15	18'-10"	17'-9"	16'-5"	22'-3"	21'-1"	19'-6"	24'-3"	23'-7"	22'-3"	25'-11"	25'-3"	24'-4"
		30	10	18'-10"	17'-10"	16'-8"	22'-4"	21'-3"	19'-10"	24'-4"	23'-11"	22'-7"	26'-0"	25'-7"	24'-11"
		30	15	18'-1"	17'-1"	15'-10"	21'-0"	20'-4"	18'-10"	22'-10"	22'-4"	21'-6"	24'-5"	23'-11"	23'-1"
		40	10	17'-1"	16'-5"	15'-6"	20'-0"	19'-7"	18'-6"	21'-9"	21'-5"	21'-0"	23'-3"	22'-11"	22'-3"
Snow 115%	40	15	16'-9"	16'-0"	14'-11"	19'-0"	18'-7"	17'-9"	20'-8"	20'-4"	19'-3"	21'-7"	20'-9"	19'-8"	
	50	10	15'-10"	15'-2"	14'-5"	18'-3"	18'-0"	17'-3"	19'-6"	19'-0"	18'-5"	19'-10"	19'-5"	18'-9"	
50	15	15'-5"	15'-1"	14'-1"	17'-3"	16'-8"	15'-11"	17'-11"	17'-4"	16'-6"	18'-3"	17'-8"	16'-10"		



Roof Span Tables

Maximum clear span in feet and inches, based on horizontal spans.

115% and 125% Load Duration												
			BCI® 60 2.0 Series 2 ⁵ / ₁₆ " Flange Width									
			11 ⁷ / ₈ " BCI® 60 2.0			14" BCI® 60 2.0			16" BCI® 60 2.0			
		Live Load [psf]	Dead Load [psf]	4/12 or Less	4/12 to 8/12	8/12 to 12/12	4/12 or Less	4/12 to 8/12	8/12 to 12/12	4/12 or Less	4/12 to 8/12	8/12 to 12/12
12" o.c.	Non-Snow 125%	20	10	33'-7"	31'-8"	29'-5"	38'-4"	36'-1"	33'-6"	42'-5"	40'-0"	37'-1"
		20	15	31'-10"	29'-11"	27'-7"	36'-3"	34'-1"	31'-5"	40'-2"	37'-8"	34'-10"
		20	20	30'-4"	28'-5"	26'-2"	34'-7"	32'-5"	29'-9"	38'-4"	35'-10"	33'-0"
	Snow 115%	25	10	31'-11"	30'-2"	28'-1"	36'-4"	34'-4"	32'-0"	40'-3"	38'-1"	35'-5"
		25	15	30'-5"	28'-8"	26'-6"	34'-8"	32'-8"	30'-3"	38'-5"	36'-2"	33'-6"
		30	10	30'-6"	28'-11"	26'-11"	34'-9"	32'-11"	30'-8"	38'-6"	36'-5"	34'-0"
		30	15	29'-3"	27'-7"	25'-7"	33'-4"	31'-5"	29'-2"	36'-11"	34'-10"	32'-4"
		40	10	27'-9"	26'-7"	25'-2"	31'-8"	30'-4"	28'-8"	35'-0"	33'-7"	31'-9"
		40	15	27'-4"	25'-10"	24'-1"	31'-2"	29'-6"	27'-6"	34'-6"	32'-8"	30'-5"
		50	10	25'-9"	24'-8"	23'-5"	29'-4"	28'-1"	26'-8"	32'-5"	31'-1"	29'-6"
	50	15	25'-9"	24'-6"	22'-11"	29'-4"	27'-11"	26'-1"	32'-5"	30'-11"	28'-11"	
	16" o.c.	Non-Snow 125%	20	10	30'-5"	28'-9"	26'-8"	34'-9"	32'-9"	30'-5"	38'-5"	36'-3"
20			15	28'-10"	27'-1"	25'-0"	32'-10"	30'-10"	28'-6"	36'-5"	34'-2"	31'-7"
20			20	27'-6"	25'-9"	23'-8"	31'-4"	29'-4"	27'-0"	34'-9"	32'-6"	29'-11"
Snow 115%		25	10	28'-11"	27'-4"	25'-5"	32'-11"	31'-2"	29'-0"	36'-6"	34'-6"	32'-1"
		25	15	27'-7"	26'-0"	24'-1"	31'-5"	29'-7"	27'-5"	34'-10"	32'-9"	30'-4"
		30	10	27'-8"	26'-2"	24'-5"	31'-6"	29'-10"	27'-10"	34'-11"	33'-0"	30'-10"
		30	15	26'-6"	25'-0"	23'-3"	30'-2"	28'-6"	26'-6"	33'-5"	31'-7"	29'-4"
		40	10	25'-2"	24'-1"	22'-9"	28'-8"	27'-6"	26'-0"	31'-9"	30'-5"	28'-9"
		40	15	24'-9"	23'-5"	21'-10"	28'-3"	26'-8"	24'-11"	31'-3"	29'-7"	27'-7"
		50	10	23'-3"	22'-4"	21'-2"	26'-6"	25'-5"	24'-2"	29'-5"	28'-2"	26'-9"
50		15	23'-3"	22'-2"	20'-9"	26'-6"	25'-3"	23'-8"	28'-7"	27'-8"	26'-2"	
19.2" o.c.		Non-Snow 125%	20	10	28'-7"	27'-0"	25'-1"	32'-7"	30'-9"	28'-7"	36'-1"	34'-1"
	20		15	27'-1"	25'-5"	23'-6"	30'-10"	29'-0"	26'-9"	34'-2"	32'-1"	29'-8"
	20		20	25'-10"	24'-2"	22'-3"	29'-5"	27'-7"	25'-4"	32'-7"	30'-6"	28'-1"
	Snow 115%	25	10	27'-2"	25'-8"	23'-11"	30'-11"	29'-3"	27'-3"	34'-3"	32'-5"	30'-2"
		25	15	25'-11"	24'-5"	22'-7"	29'-6"	27'-10"	25'-9"	32'-8"	30'-9"	28'-6"
		30	10	25'-11"	24'-7"	22'-11"	29'-7"	28'-0"	26'-2"	32'-9"	31'-0"	29'-0"
		30	15	24'-11"	23'-6"	21'-10"	28'-4"	26'-9"	24'-10"	31'-5"	29'-8"	27'-6"
		40	10	23'-7"	22'-8"	21'-5"	26'-11"	25'-10"	24'-5"	29'-10"	28'-7"	27'-0"
		40	15	23'-3"	22'-0"	20'-6"	26'-6"	25'-1"	23'-5"	28'-1"	27'-0"	25'-7"
		50	10	21'-10"	21'-0"	19'-11"	24'-11"	23'-11"	22'-8"	25'-10"	25'-3"	24'-5"
	50	15	21'-10"	20'-10"	19'-6"	23'-9"	23'-0"	21'-11"	23'-9"	23'-0"	21'-11"	
	24" o.c.	Non-Snow 125%	20	10	26'-6"	25'-0"	23'-3"	30'-2"	28'-6"	26'-6"	33'-5"	31'-7"
20			15	25'-1"	23'-7"	21'-9"	28'-7"	26'-10"	24'-10"	31'-8"	29'-9"	27'-6"
20			20	23'-11"	22'-5"	20'-7"	27'-3"	25'-6"	23'-6"	30'-2"	28'-3"	26'-0"
Snow 115%		25	10	25'-2"	23'-9"	22'-2"	28'-8"	27'-1"	25'-3"	31'-9"	30'-0"	28'-0"
		25	15	24'-0"	22'-7"	20'-11"	27'-4"	25'-9"	23'-10"	30'-3"	28'-6"	26'-5"
		30	10	24'-0"	22'-9"	21'-3"	27'-5"	25'-11"	24'-3"	30'-4"	28'-9"	26'-10"
		30	15	23'-0"	21'-9"	20'-2"	26'-3"	24'-9"	23'-0"	27'-4"	26'-1"	24'-5"
		40	10	21'-10"	21'-0"	19'-10"	24'-9"	23'-11"	22'-7"	24'-9"	24'-1"	23'-1"
		40	15	21'-6"	20'-4"	19'-0"	22'-5"	21'-6"	20'-5"	22'-5"	21'-6"	20'-5"
		50	10	20'-2"	19'-5"	18'-5"	20'-8"	20'-2"	19'-6"	20'-8"	20'-2"	19'-6"
50		15	19'-0"	18'-4"	17'-6"	19'-0"	18'-4"	17'-6"	19'-0"	18'-4"	17'-6"	

- Table values are limited by shear, moment, total load deflection equal to L/180 and live load deflection equal to L/240. Check the local building code for other deflection limits that may apply.
- This table was designed to apply to a broad range of applications. It may be possible to exceed the limitations of this table by analyzing a specific application with the BC CALC® software.
- Table values represent the most restrictive of simple or multiple span applications.
- Slope roof joists at least 1/4" over 12" to minimize ponding.
- Table values assume minimum bearing lengths without web stiffeners for joist depths of 16 inches and less. 18 and 20 inch joists require web stiffeners.
- Allowable spans and loads shall be adjusted and checked for wind load as required by local building code.

Roof Span Tables

Maximum clear span in feet and inches, based on horizontal spans.

115% and 125% Load Duration

			BCI® 90 2.0 Series 3 1/2" Flange Width																			
			11 7/8" BCI® 90 2.0			14" BCI® 90 2.0			16" BCI® 90 2.0			18" BCI® 90 2.0			20" BCI® 90 2.0							
			4/12 or Less	4/12 to 8/12	8/12 to 12/12	4/12 or Less	4/12 to 8/12	8/12 to 12/12	4/12 or Less	4/12 to 8/12	8/12 to 12/12	4/12 or Less	4/12 to 8/12	8/12 to 12/12	4/12 or Less	4/12 to 8/12	8/12 to 12/12	4/12 or Less	4/12 to 8/12	8/12 to 12/12		
Clear Span	Load Type	Live Load [psf]	Dead Load [psf]																			
		12" o.c.	Non-Snow 125%	20	10	38'-5"	36'-3"	33'-8"	43'-7"	41'-2"	38'-2"	48'-4"	45'-7"	42'-3"	50'-0"	49'-9"	46'-2"	50'-0"	50'-0"	50'-0"	50'-0"	50'-0"
20	15			36'-5"	34'-2"	31'-7"	41'-4"	38'-10"	35'-10"	45'-9"	43'-0"	39'-8"	50'-0"	46'-11"	43'-4"	50'-0"	50'-0"	50'-0"	50'-0"	46'-11"		
20	20			34'-9"	32'-6"	29'-11"	39'-5"	36'-11"	33'-11"	43'-8"	40'-10"	37'-7"	47'-8"	44'-8"	41'-1"	50'-0"	48'-4"	44'-5"				
Snow 115%	25		10	36'-6"	34'-6"	32'-1"	41'-5"	39'-2"	36'-5"	45'-10"	43'-4"	40'-4"	50'-0"	47'-5"	44'-1"	50'-0"	50'-0"	47'-9"				
	25		15	34'-10"	32'-9"	30'-4"	39'-6"	37'-2"	34'-5"	43'-9"	41'-2"	38'-2"	47'-10"	45'-0"	41'-8"	50'-0"	48'-8"	45'-1"				
	30		10	34'-11"	33'-1"	30'-10"	39'-7"	37'-6"	35'-0"	43'-10"	41'-6"	38'-9"	47'-11"	45'-5"	42'-4"	50'-0"	49'-1"	45'-10"				
	30		15	33'-5"	31'-7"	29'-4"	38'-0"	35'-10"	33'-3"	42'-1"	39'-8"	36'-10"	45'-11"	43'-4"	40'-3"	49'-9"	46'-11"	43'-7"				
	40		10	31'-9"	30'-5"	28'-9"	36'-0"	34'-7"	32'-8"	39'-11"	38'-3"	36'-2"	43'-7"	41'-10"	39'-6"	47'-2"	45'-3"	42'-9"				
	40		15	31'-3"	29'-7"	27'-7"	35'-6"	33'-7"	31'-3"	39'-3"	37'-2"	34'-8"	42'-11"	40'-8"	37'-10"	46'-5"	44'-0"	41'-0"				
	50		10	29'-5"	28'-2"	26'-9"	33'-4"	32'-0"	30'-5"	36'-11"	35'-5"	33'-8"	40'-5"	38'-9"	36'-9"	43'-8"	41'-11"	39'-10"				
	50		15	29'-5"	28'-0"	26'-2"	33'-4"	31'-9"	29'-8"	36'-11"	35'-3"	32'-11"	40'-5"	38'-6"	36'-0"	43'-8"	41'-8"	38'-11"				
16" o.c.	Non-Snow 125%		20	10	34'-10"	32'-10"	30'-6"	39'-6"	37'-4"	34'-7"	43'-9"	41'-4"	38'-4"	47'-10"	45'-2"	41'-11"	50'-0"	48'-10"	45'-4"			
			20	15	33'-0"	31'-0"	28'-7"	37'-5"	35'-2"	32'-6"	41'-5"	38'-11"	36'-0"	45'-4"	42'-7"	39'-4"	49'-0"	46'-1"	42'-6"			
			20	20	31'-6"	29'-6"	27'-1"	35'-8"	33'-5"	30'-9"	39'-7"	37'-0"	34'-1"	43'-3"	40'-6"	37'-3"	46'-9"	43'-10"	40'-3"			
	Snow 115%	25	10	33'-1"	31'-3"	29'-1"	37'-6"	35'-6"	33'-1"	41'-7"	39'-4"	36'-7"	45'-5"	42'-11"	40'-0"	49'-2"	46'-6"	43'-3"				
		25	15	31'-6"	29'-8"	27'-6"	35'-9"	33'-8"	31'-3"	39'-8"	37'-4"	34'-7"	43'-4"	40'-10"	37'-9"	46'-10"	44'-2"	40'-11"				
		30	10	31'-7"	29'-11"	27'-11"	35'-10"	34'-0"	31'-9"	39'-9"	37'-8"	35'-2"	43'-5"	41'-2"	38'-5"	47'-0"	44'-6"	41'-6"				
		30	15	30'-4"	28'-7"	26'-7"	34'-5"	32'-5"	30'-2"	38'-1"	35'-11"	33'-5"	41'-7"	39'-3"	36'-6"	45'-0"	42'-6"	39'-6"				
		40	10	28'-9"	27'-7"	26'-1"	32'-7"	31'-4"	29'-7"	36'-2"	34'-8"	32'-9"	39'-6"	37'-11"	35'-10"	42'-9"	41'-0"	38'-9"				
		40	15	28'-4"	26'-9"	25'-0"	32'-1"	30'-5"	28'-4"	35'-7"	33'-8"	31'-5"	38'-10"	36'-10"	34'-4"	42'-1"	39'-10"	37'-2"				
		50	10	26'-7"	25'-6"	24'-3"	30'-2"	29'-0"	27'-6"	33'-5"	32'-1"	30'-6"	36'-7"	35'-1"	33'-4"	39'-7"	38'-0"	36'-1"				
		50	15	26'-7"	25'-4"	23'-9"	30'-2"	28'-9"	26'-11"	33'-5"	31'-11"	29'-10"	36'-7"	34'-10"	32'-7"	39'-7"	37'-8"	35'-3"				
	19.2" o.c.	Non-Snow 125%	20	10	32'-9"	30'-11"	28'-8"	37'-2"	35'-0"	32'-6"	41'-2"	38'-10"	36'-0"	44'-11"	42'-5"	39'-4"	48'-8"	45'-11"	42'-7"			
			20	15	31'-0"	29'-1"	26'-11"	35'-2"	33'-0"	30'-6"	38'-11"	36'-7"	33'-9"	42'-7"	40'-0"	36'-11"	46'-0"	43'-3"	39'-11"			
			20	20	29'-6"	27'-8"	25'-5"	33'-6"	31'-5"	28'-11"	37'-2"	34'-9"	32'-0"	40'-7"	38'-0"	35'-0"	43'-11"	41'-2"	37'-10"			
Snow 115%		25	10	31'-1"	29'-5"	27'-4"	35'-3"	33'-4"	31'-1"	39'-0"	36'-11"	34'-5"	42'-8"	40'-4"	37'-7"	46'-2"	43'-8"	40'-8"				
		25	15	29'-7"	27'-11"	25'-10"	33'-7"	31'-8"	29'-4"	37'-3"	35'-1"	32'-6"	40'-8"	38'-4"	35'-7"	44'-0"	41'-6"	38'-5"				
		30	10	29'-8"	28'-1"	26'-3"	33'-8"	31'-11"	29'-10"	37'-4"	35'-4"	33'-0"	40'-9"	38'-8"	36'-1"	44'-1"	41'-10"	39'-0"				
		30	15	28'-5"	26'-10"	24'-11"	32'-3"	30'-6"	28'-4"	35'-9"	33'-9"	31'-4"	39'-1"	36'-11"	34'-3"	42'-3"	39'-11"	37'-1"				
		40	10	27'-0"	25'-11"	24'-6"	30'-7"	29'-5"	27'-9"	33'-11"	32'-7"	30'-9"	37'-1"	35'-7"	33'-7"	40'-1"	38'-6"	36'-5"				
		40	15	26'-7"	25'-2"	23'-5"	30'-2"	28'-7"	26'-7"	33'-5"	31'-7"	29'-6"	36'-6"	34'-7"	32'-3"	39'-6"	37'-5"	34'-11"				
		50	10	24'-11"	24'-0"	22'-9"	28'-4"	27'-2"	25'-10"	31'-5"	30'-2"	28'-8"	34'-4"	32'-11"	31'-4"	37'-1"	35'-8"	33'-10"				
		50	15	24'-11"	23'-10"	22'-3"	28'-4"	27'-0"	25'-3"	29'-8"	28'-8"	27'-5"	34'-4"	32'-8"	30'-7"	37'-1"	35'-5"	33'-1"				
24" o.c.		Non-Snow 125%	20	10	30'-4"	28'-7"	26'-7"	34'-5"	32'-5"	30'-2"	38'-1"	35'-11"	33'-5"	41'-7"	39'-3"	36'-6"	45'-0"	42'-6"	39'-6"			
			20	15	28'-8"	26'-11"	24'-11"	32'-6"	30'-7"	28'-3"	36'-1"	33'-11"	31'-4"	39'-5"	37'-0"	34'-2"	42'-8"	40'-1"	37'-0"			
			20	20	27'-4"	25'-7"	23'-7"	31'-0"	29'-1"	26'-9"	34'-4"	32'-2"	29'-8"	37'-7"	35'-2"	32'-5"	40'-8"	38'-1"	35'-1"			
	Snow 115%	25	10	28'-9"	27'-2"	25'-4"	32'-7"	30'-10"	28'-9"	36'-2"	34'-2"	31'-10"	39'-6"	37'-4"	34'-10"	42'-9"	40'-5"	37'-8"				
		25	15	27'-5"	25'-10"	23'-11"	31'-1"	29'-4"	27'-2"	34'-5"	32'-6"	30'-1"	37'-8"	35'-6"	32'-11"	40'-9"	38'-5"	35'-7"				
		30	10	27'-6"	26'-0"	24'-4"	31'-2"	29'-7"	27'-7"	34'-6"	32'-9"	30'-7"	37'-9"	35'-9"	33'-5"	40'-10"	38'-9"	36'-2"				
		30	15	26'-4"	24'-10"	23'-1"	29'-10"	28'-2"	26'-3"	33'-1"	31'-3"	29'-1"	36'-2"	34'-2"	31'-9"	39'-2"	37'-0"	34'-4"				
		40	10	24'-11"	24'-0"	22'-8"	28'-4"	27'-2"	25'-9"	30'-11"	30'-0"	28'-6"	34'-4"	32'-11"	31'-2"	37'-1"	35'-8"	33'-8"				
		40	15	24'-7"	23'-3"	21'-9"	27'-9"	26'-5"	24'-8"	28'-0"	26'-11"	25'-6"	33'-9"	32'-0"	29'-10"	35'-2"	33'-10"	32'-1"				
		50	10	23'-1"	22'-2"	21'-1"	25'-7"	24'-11"	23'-11"	25'-9"	25'-2"	24'-4"	31'-3"	30'-6"	29'-0"	32'-5"	31'-8"	30'-7"				
		50	15	23'-1"	22'-0"	20'-7"	23'-6"	22'-9"	21'-8"	23'-8"	22'-11"	21'-10"	28'-9"	27'-10"	26'-7"	29'-10"	28'-10"	27'-6"				

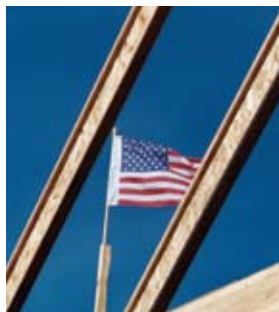

Allowable Uniform Roof Load (in pounds per lineal foot [PLF])

115% and 125% Load Duration

Use of these tables should be limited to roof slopes of 3 1/2" per foot or less.
For steeper slopes, see pages 15-18.

Span Length	BCI® 5000 1.7 Series 2" Flange Width								
	9 1/2" BCI® 5000 1.7			11 7/8" BCI® 5000 1.7			14" BCI® 5000 1.7		
	Total Load		Deflect.	Total Load		Deflect.	Total Load		Deflect.
	Snow (115%)	Non-Snow (125%)	L/240	Snow (115%)	Non-Snow (125%)	L/240	Snow (115%)	Non-Snow (125%)	L/240
6	315	343	-	338	367	-	353	383	-
7	270	294	-	289	315	-	302	329	-
8	236	257	-	253	275	-	264	287	-
9	210	228	-	225	245	-	235	255	-
10	189	205	-	202	220	-	211	230	-
11	172	187	-	184	200	-	192	209	-
12	154	167	-	169	183	-	176	191	-
13	131	142	-	156	169	-	162	177	-
14	113	123	110	144	157	-	151	164	-
15	98	107	90	126	137	-	141	153	-
16	86	94	75	110	120	-	131	142	-
17	76	82	63	98	106	-	116	126	-
18	68	70	53	87	95	-	103	112	-
19	59	59	45	78	85	74	93	101	-
20	51	51	39	71	77	64	84	91	-
21				64	70	55	76	83	-
22				58	63	48	69	75	-
23				53	55	42	63	69	62
24							58	63	55
25							53	58	49
26									
27									
28									

- Total Load values are limited by shear, moment, or deflection equal to L/180.
- Deflection values (Deflect.) are limited by live load deflection equal to L/240. Check the local building code for other deflection limits that may apply.
- Both the Total Load and Deflection columns must be checked. Where a Deflection value is not shown, the Total Load value will control.
- Table values apply to either simple or multiple span joists. Span is measured center to center of the minimum required bearing length. Analyze multiple span joists with the BC CALC® software if the length of any span is less than half the length of an adjacent span.
- Slope roof joists at least 1/4 inch over 12 inches to minimize ponding.
- Table values assume minimum bearing lengths without web stiffeners for joist depths of 16 inches and less. 18 and 20 inch joists require web stiffeners.
- This table was designed to apply to a broad range of applications. It may be possible to exceed the limitations of this table by analyzing a specific application with the BC CALC® software.
- Allowable spans and loads shall be adjusted and checked for wind load as required by local building code.

Roof Load Tables

Allowable Uniform Roof Load (in pounds per lineal foot [PLF])

115% and 125% Load Duration

Use of these tables should be limited to roof slopes of 3¹/₂" per foot or less.
For steeper slopes, see pages 15-18.

Span Length	BCI® 6000 1.7 Series 2 ⁵ / ₁₆ " Flange Width											
	9 ¹ / ₂ " BCI® 6000 1.7			11 ⁷ / ₈ " BCI® 6000 1.7			14" BCI® 6000 1.7			16" BCI® 6000 1.7		
	Total Load		Deflect.	Total Load		Deflect.	Total Load		Deflect.	Total Load		Deflect.
	Snow (115%)	Non-Snow (125%)	L/240	Snow (115%)	Non-Snow (125%)	L/240	Snow (115%)	Non-Snow (125%)	L/240	Snow (115%)	Non-Snow (125%)	L/240
6	360	392	-	375	408	-	390	424	-	398	432	-
7	309	336	-	322	350	-	334	364	-	341	371	-
8	270	294	-	281	306	-	293	318	-	298	324	-
9	240	261	-	250	272	-	260	283	-	265	288	-
10	216	235	-	225	245	-	234	254	-	238	259	-
11	196	213	-	204	222	-	213	231	-	217	236	-
12	179	194	-	187	204	-	195	212	-	199	216	-
13	152	166	151	173	188	-	180	196	-	183	199	-
14	131	143	123	161	175	-	167	182	-	170	185	-
15	114	124	101	147	159	-	156	169	-	159	173	-
16	100	109	84	129	140	-	146	159	-	149	162	-
17	89	92	70	114	124	-	135	147	-	140	152	-
18	78	78	59	102	111	99	121	131	-	132	144	-
19	66	66	51	91	99	85	108	118	-	124	134	-
20	57	57	44	82	89	73	98	106	-	111	121	-
21	50	50	38	75	81	63	88	96	-	101	110	-
22				68	72	55	81	88	-	92	100	-
23				62	64	49	74	80	71	84	91	-
24				56	56	43	68	74	62	77	84	-
25				50	50	38	62	68	55	71	77	-
26							58	63	49	66	71	-
27							53	58	44	61	66	60
28							50	52	40	57	62	54



Allowable Uniform Roof Load (in pounds per lineal foot [PLF])

115% and 125% Load Duration

Use of these tables should be limited to roof slopes of 3 1/2" per foot or less.
For steeper slopes, see pages 15-18.

Span Length	BCI® 6500 1.8 Series 2 ⁹ / ₁₆ " Flange Width											
	9 1/2" BCI® 6500 1.8			11 7/8" BCI® 6500 1.8			14" BCI® 6500 1.8			16" BCI® 6500 1.8		
	Total Load		Deflect.	Total Load		Deflect.	Total Load		Deflect.	Total Load		Deflect.
	Snow (115%)	Non-Snow (125%)	L/240	Snow (115%)	Non-Snow (125%)	L/240	Snow (115%)	Non-Snow (125%)	L/240	Snow (115%)	Non-Snow (125%)	L/240
6	360	392	-	375	408	-	390	424	-	398	432	-
7	309	336	-	322	350	-	334	364	-	341	371	-
8	270	294	-	281	306	-	293	318	-	298	324	-
9	240	261	-	250	272	-	260	283	-	265	288	-
10	216	235	-	225	245	-	234	254	-	238	259	-
11	196	213	-	204	222	-	213	231	-	217	236	-
12	180	196	-	187	204	-	195	212	-	199	216	-
13	166	180	-	173	188	-	180	196	-	183	199	-
14	154	168	141	161	175	-	167	182	-	170	185	-
15	140	152	116	150	163	-	156	169	-	159	173	-
16	123	126	97	140	153	-	146	159	-	149	162	-
17	106	106	81	132	144	-	137	149	-	140	152	-
18	90	90	69	125	135	114	130	141	-	132	144	-
19	77	77	59	112	122	97	123	134	-	125	136	-
20	66	66	51	101	110	84	117	127	-	119	129	-
21	57	57	44	91	95	73	108	118	106	113	123	-
22	50	50	38	83	83	64	99	107	92	108	118	-
23				73	73	56	90	98	81	103	112	-
24				64	64	49	83	90	72	95	103	-
25				57	57	44	76	83	64	87	95	85
26				51	51	39	71	74	57	81	88	76
27							65	67	51	75	81	68
28							60	60	46	69	76	61
29							54	54	41	65	70	55
30										60	66	50
31										57	60	45
32										53	54	41
33										50	50	38
34												
35												

- Total Load values are limited by shear, moment, or deflection equal to L/180.
- Deflection values (Deflect.) are limited by live load deflection equal to L/240. Check the local building code for other deflection limits that may apply.
- Both the Total Load and Deflection columns must be checked. Where a Deflection value is not shown, the Total Load value will control.

- Table values apply to either simple or multiple span joists. Span is measured center to center of the minimum required bearing length. Analyze multiple span joists with the BC CALC® software if the length of any span is less than half the length of an adjacent span.
- Slope roof joists at least 1/4 inch over 12 inches to minimize ponding.

- Table values assume minimum bearing lengths without web stiffeners for joist depths of 16 inches and less. 18 and 20 inch joists require web stiffeners.
- This table was designed to apply to a broad range of applications. It may be possible to exceed the limitations of this table by analyzing a specific application with the BC CALC® software.
- Allowable spans and loads shall be adjusted and checked for wind load as required by local building code.

Roof Load Tables

Allowable Uniform Roof Load (in pounds per lineal foot [PLF])

115% and 125% Load Duration

Use of these tables should be limited to roof slopes of 3 1/2" per foot or less.
For steeper slopes, see pages 15-18.

Span Length	BCI® 60 2.0 Series 2 ⁵ / ₁₆ " Flange Width								
	11 ⁷ / ₈ " BCI® 60 2.0			14" BCI® 60 2.0			16" BCI® 60 2.0		
	Total Load		Deflect.	Total Load		Deflect.	Total Load		Deflect.
	Snow (115%)	Non-Snow (125%)	L/240	Snow (115%)	Non-Snow (125%)	L/240	Snow (115%)	Non-Snow (125%)	L/240
6	413	449	-	413	449	-	413	449	-
7	354	385	-	354	385	-	354	385	-
8	309	336	-	309	336	-	309	336	-
9	275	299	-	275	299	-	275	299	-
10	247	269	-	247	269	-	247	269	-
11	225	245	-	225	245	-	225	245	-
12	206	224	-	206	224	-	206	224	-
13	190	207	-	190	207	-	190	207	-
14	177	192	-	177	192	-	177	192	-
15	165	179	-	165	179	-	165	179	-
16	154	168	-	154	168	-	154	168	-
17	145	158	-	145	158	-	145	158	-
18	137	149	-	137	149	-	137	149	-
19	130	141	118	130	141	-	130	141	-
20	123	133	102	123	134	-	123	134	-
21	116	116	88	118	128	-	118	128	-
22	101	101	77	112	122	-	112	122	-
23	89	89	68	107	117	99	107	117	-
24	79	79	60	103	112	88	103	112	-
25	70	70	53	99	102	78	99	107	-
26	62	62	47	91	91	69	95	103	93
27	56	56	42	81	81	62	91	99	84
28	50	50	38	73	73	56	88	96	75
29				66	66	50	85	89	68
30				60	60	46	81	81	61
31				54	54	41	73	73	56
32							67	67	51
33							61	61	46
34							56	56	43
35							51	51	39



Allowable Uniform Roof Load (in pounds per lineal foot [PLF])

115% and 125% Load Duration

Use of these tables should be limited to roof slopes of 3 1/2" per foot or less.
For steeper slopes, see pages 15-18.

Span Length	BCI® 90 2.0 Series 3 1/2" Flange Width														
	11 7/8" BCI® 90 2.0			14" BCI® 90 2.0			16" BCI® 90 2.0			18" BCI® 90 2.0			20" BCI® 90 2.0		
	Total Load		Deflect.	Total Load		Deflect.	Total Load		Deflect.	Total Load		Deflect.	Total Load		Deflect.
	Snow (115%)	Non-Snow (125%)	L/240	Snow (115%)	Non-Snow (125%)	L/240	Snow (115%)	Non-Snow (125%)	L/240	Snow (115%)	Non-Snow (125%)	L/240	Snow (115%)	Non-Snow (125%)	L/240
6	507	551	-	510	555	-	514	559	-	623	677	-	646	702	-
7	434	472	-	437	476	-	441	479	-	534	581	-	553	602	-
8	380	413	-	383	416	-	385	419	-	467	508	-	484	526	-
9	338	367	-	340	370	-	343	372	-	415	451	-	430	468	-
10	304	330	-	306	333	-	308	335	-	374	406	-	387	421	-
11	276	300	-	278	302	-	280	305	-	340	369	-	352	383	-
12	253	275	-	255	277	-	257	279	-	311	338	-	323	351	-
13	234	254	-	235	256	-	237	258	-	287	312	-	298	324	-
14	217	236	-	218	238	-	220	239	-	267	290	-	276	301	-
15	202	220	-	204	222	-	205	223	-	249	271	-	258	280	-
16	190	206	-	191	208	-	192	209	-	233	254	-	242	263	-
17	178	194	-	180	196	-	181	197	-	220	239	-	228	247	-
18	169	183	-	170	185	-	171	186	-	207	225	-	215	234	-
19	160	174	-	161	175	-	162	176	-	196	214	-	204	221	-
20	152	165	148	153	166	-	154	167	-	187	203	-	193	210	-
21	144	157	129	145	158	-	147	159	-	178	193	-	184	200	-
22	138	148	113	139	151	-	140	152	-	170	184	-	176	191	-
23	130	130	100	133	144	-	134	145	-	162	176	-	168	183	-
24	115	115	88	127	138	126	128	139	-	155	169	-	161	175	-
25	103	103	78	122	133	112	123	134	-	149	162	-	155	168	-
26	92	92	70	117	128	100	118	129	-	143	156	-	149	162	-
27	82	82	63	113	118	90	114	124	-	138	150	-	143	156	-
28	74	74	56	106	106	81	110	119	109	133	145	-	138	150	-
29	67	67	51	96	96	73	106	115	98	129	140	127	133	145	-
30	60	60	46	87	87	67	102	111	89	124	135	115	129	140	-
31	55	55	42	79	79	60	99	106	81	120	131	105	125	135	-
32	50	50	38	72	72	55	96	97	74	116	125	96	121	131	120
33				66	66	50	89	89	68	113	114	88	117	127	110
34				60	60	46	81	81	62	105	105	80	114	123	101

- Total Load values are limited by shear, moment, or deflection equal to L/180.
- Deflection values (Deflect.) are limited by live load deflection equal to L/240. Check the local building code for other deflection limits that may apply.
- Both the Total Load and Deflection columns must be checked. Where a Deflection value is not shown, the Total Load value will control.
- Table values apply to either simple or multiple span joists. Span is measured center to center of the minimum required bearing length. Analyze multiple span joists with the BC CALC® software if the length of any span is less than half the length of an adjacent span.
- Slope roof joists at least 1/4 inch over 12 inches to minimize ponding.
- Table values assume minimum bearing lengths without web stiffeners for joist depths of 16 inches and less. 18 and 20 inch joists require web stiffeners.
- This table was designed to apply to a broad range of applications. It may be possible to exceed the limitations of this table by analyzing a specific application with the BC CALC® software.
- Allowable spans and loads shall be adjusted and checked for wind load as required by local building code.