



**Boise Cascade**  
*Engineered Wood Products*

# **BOISE GLULAM<sup>®</sup>**

## **Beam Specifier Guide**



# . . . Just ask for BOISE GLULAM® beams

**Glued laminated timbers from Boise Engineered Wood Products add functional beauty to any residential or commercial project.**

## Just ask for BOISE GLULAM® beams.

No discussion of engineered wood products is complete without mention of glued laminated timber. Glulams are sometimes forgotten in what has become an increasingly crowded field of newer products.

Laminated timbers are often the most cost-effective and easy-to-install alternative for beam applications to residential, commercial and light industrial construction. It is usually easy to determine whether to specify a balanced or unbalanced layup and whether to choose Industrial or Architectural appearance grade beams.

The benefit to BOISE GLULAM® beams is that they can be manufactured either with or without camber. Most stock beams are available with either a small amount of camber (3,500' radius) or no camber, depending on market demands.

BOISE GLULAM® beams are manufactured from Douglas Fir-Larch and carry the AITC trademark.

### STOCK BEAMS

For most residential applications, stock beams are the product of choice. BOISE GLULAM® stock beams are available through our trusted distributors, located strategically throughout the country. Our beams are manufactured in widths of 3<sup>1</sup>/<sub>8</sub>", 3<sup>1</sup>/<sub>2</sub>", 5<sup>1</sup>/<sub>8</sub>", 5<sup>1</sup>/<sub>2</sub>", 6<sup>3</sup>/<sub>4</sub>", and 8<sup>3</sup>/<sub>4</sub>", with depths ranging from 6" to 24" and lengths up to 66 feet, with or without camber. Stock beams are available in Architectural appearance grade, which is intended for exposed applications but can also be used for concealed beams, headers, columns, and rafters. Check with your local distributor for availability.

### I-JOIST COMPATIBLE BEAMS

IJC (I- Joist Compatible) sizes are readily available. Consult your local distributor for availability. IJC sizes have proven to be cost effective product options to other structural members such as LVL.

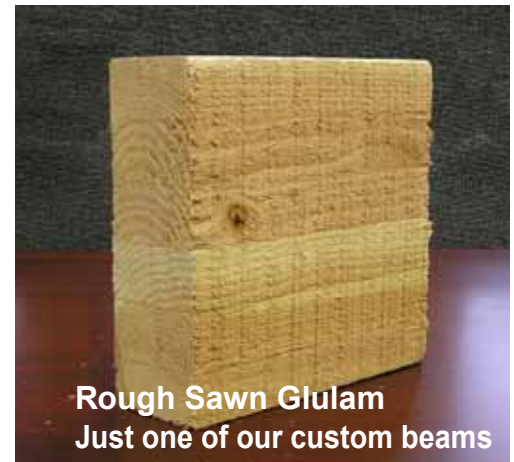

**Rough Sawn Glulam**  
Just one of our custom beams

### CUSTOM BEAMS

Custom beams are manufactured in typical widths of 3<sup>1</sup>/<sub>8</sub>" through 12<sup>1</sup>/<sub>4</sub>", with even greater widths subject to inquire and in depths ranging from 6" to over 48". They are used when large cross-sections, longer lengths, curved and arched shapes, different appearances, or specific certifications are required. BOISE GLULAM® custom beams are manufactured on a made-to-order basis. Please call to determine availability of BOISE GLULAM® custom beams.

## Table of Contents

<b>Stock Beams, Custom Beams</b> .....	<b>2</b>	<b>Allowable Holes</b> .....	<b>8</b>
<b>Architectural Appearance Beams, Industrial Appearance Beams</b> .....	<b>3</b>	<b>Common Details</b> .....	<b>9</b>
<b>Columns, Headers</b> .....	<b>3</b>	<b>BOISE GLULAM® Beams Floor Load Tables - 100%</b> .....	<b>10 - 14</b>
<b>Balanced and Unbalanced Beam Layups, Layup Combinations</b> .....	<b>3</b>	<b>BOISE GLULAM® Beams Roof Load Tables - 115%</b> .....	<b>15 - 19</b>
<b>Deflection &amp; Camber, Adhesives</b> .....	<b>4</b>	<b>BOISE GLULAM® Beams Roof Load Tables - 125%</b> .....	<b>20 - 24</b>
<b>Checking, Handling &amp; Storage</b> .....	<b>4</b>	<b>BOISE GLULAM® Beams Floor &amp; Roof Application Tables</b> .....	<b>25 - 29</b>
<b>Dimensional Tolerances, Preservative Treatment Requirements</b> ....	<b>5</b>	<b>BOISE GLULAM® Beams Substitution Tables - Steel</b> .....	<b>30</b>
<b>Fire Resistance, Field Notching &amp; Drilling</b> .....	<b>5</b>	<b>BOISE GLULAM® Beams Substitution Tables - Solid Sawn</b> .....	<b>31</b>
<b>BOISE GLULAM® Building Code Evaluations</b> .....	<b>5</b>	<b>BOISE GLULAM® Beams SIMPSON Hanger Tables</b> .....	<b>32</b>
<b>BOISE GLULAM® Design Values</b> .....	<b>6</b>	<b>BOISE GLULAM® Beams USP Hanger Tables</b> .....	<b>33</b>
<b>BOISE GLULAM® Allowable Design Stresses</b> .....	<b>6</b>	<b>BOISE GLULAM® Beams Computer Software</b> .....	<b>34 - 35</b>
<b>Column Tables &amp; Allowable Stresses</b> .....	<b>7</b>	<b>Website</b> .....	<b>Back Cover</b>

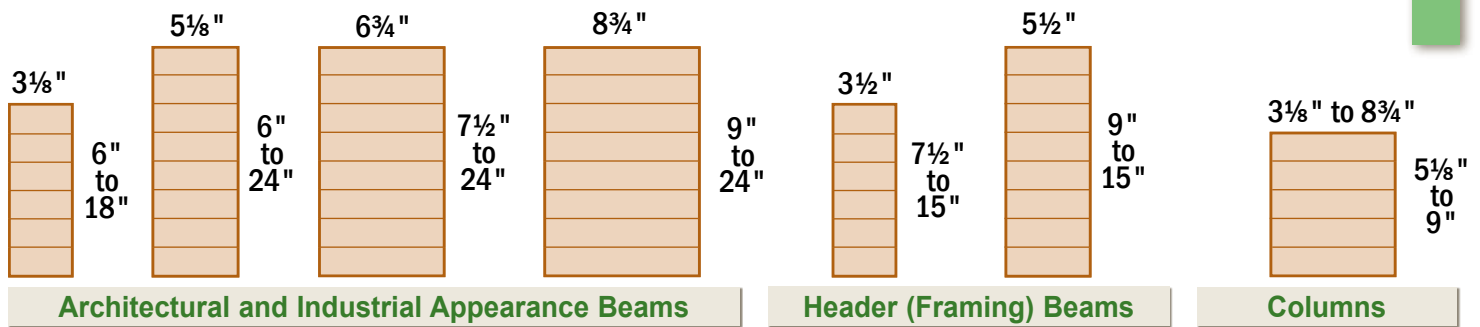

## ARCHITECTURAL APPEARANCE BEAMS

These beams are the beams of choice in applications where members are exposed to view, because they have a smooth, attractive finish. Stock beams are often supplied with this appearance so they may be exposed to view in the finished structure. Voids greater than 3/4" are filled, three sides (excluding the top) are planed or sanded, and edges are eased on the bottom face of the member.

## INDUSTRIAL APPEARANCE BEAMS

These beams are used in concealed applications or in other places where appearance is not of primary importance, such as commercial buildings, warehouses, and garages. Voids are not filled, and only the two wide faces are planed.

## COLUMNS

Glulam columns are straight and dimensionally true, making framing an easy task. Because columns are available in long lengths, the members do not have to be spliced together, as is often necessary with sawn lumber. The columns can be exposed to view as a unique architectural feature of the framing system.

BOISE GLULAM® columns have all four edges eased to match the widths of the Architectural glulams beams and have the same architectural appearance. All sides may be exposed to view.

## HEADER BEAMS

BOISE GLULAM® headers are commonly used for concealed applications such as doors and windows where appearance is not of importance. They come in two common widths, 3 1/2" and 5 1/2". Check with your local distributor for availability.

## BALANCED AND UNBALANCED BEAM LAYUPS

The most critical areas of a glulam beam are the outside laminations. Thus, the strongest laminations are placed in these areas in either unbalanced or balanced layups.

In unbalanced beams, typically known as V4s, the bottom lamination is stronger than all the other laminations. This allows for a more efficient use of timber resources. It is very important to install unbalanced BOISE GLULAM® beams with the top side up. (*The word "top" is always printed on the corresponding side.*) V4 glulams may be designed and installed in both single and multiple-span applications, and in relatively short cantilevers.

Balanced glulam beams, or V8s, have the same high-strength laminations on both the top and bottom of the beam, creating a symmetric layup. A V8 glulam can be designed for multiple-span conditions and cantilevers. V8s can also be used for single spans, but V4s are most cost-effective for this type of application. V8 BOISE GLULAM® beams may be special ordered at an additional cost; check with your local distributor for availability.

## LAYUP COMBINATIONS

### Balanced Versus Unbalanced Layup Example

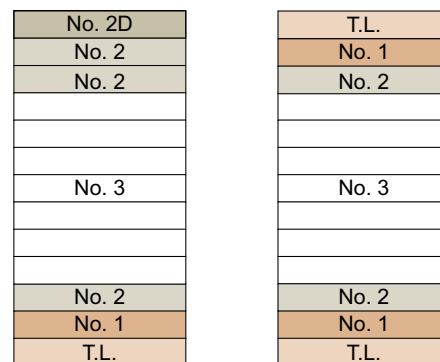

Unbalanced (V4)

Balanced (V8)

T.L. = Tension Lamination



## DEFLECTION AND CAMBER

For relatively long span lengths, deflection may control the design of glulam beams. Building codes limit deflection for floor and roof members with "L/over" limits. The "L" is simply the span length in inches. It can be divided by a number — *for example, 360 for live load on floors* — to determine the maximum amount of deflection a member can have for the corresponding span under full design loads. Thus, a greater amount of deflection is allowed for members with longer spans.

Camber is a curvature that is built into a glulam beam during the manufacturing process to offset a portion of the design load deflection. Beams may be manufactured with a 3,500' radius camber on a special order basis. The following chart displays 3,500' radius camber for the listed span lengths:

Span Length [ft]												
12	16	20	24	28	32	36	40	44	48	52	56	60
3,500' Radius Camber at Midspan [in]												
0.06	0.11	0.17	0.25	0.34	0.44	0.56	0.69	0.83	0.99	1.16	1.34	1.54

Camber is specified mostly to reduce the aesthetic effect of long-span members. Camber can also be specified to reduce the amount of deflection — *for example, it may be used to limit water collection on near-flat roofs.*

## ADHESIVES

BOISE GLULAM® beams are manufactured with exterior-grade or wet-use adhesives that comply with all recognized national glulam standards. The purpose of exterior-grade adhesives is to ensure that the design values of the beams are not compromised when the beams are directly exposed to the weather during construction. Though wet-use adhesives are required when glulam beams exceed a moisture content of 16% for extended periods of time after installation, the beams still must be protected from exterior exposure. *(For applications where moisture content may exceed 19%, see Preservative Treatment.)*  
*(ANSI/AITC Standard A190.1-2002 American National Standard for Structural Glued Laminated Timber)*

## CHECKING

Checking occurs naturally in timber when wood fibers dry. As the outer fibers lose moisture and attempt to shrink, they are restrained by the fiber in the inner portion of the beam, which loses moisture at a much slower rate. Rapid drying increases the difference in moisture content between the inner and outer fibers and thus the chances for checking in the timber member. To minimize the potential for checking, BOISE GLULAM® is produced from special grades of lumber specifically dried to less than 16% moisture content. Contact Boise EWP Engineering for technical guidance.



Example of Checking

## HANDLING & STORAGE

Water-resistant wrapping is often specified to protect beams from moisture, soiling, and surface scratches during transit and job-site storage. Because exposure to sunlight can discolor beams, opaque wrappings are recommended. Beams can be wrapped individually or by the bundle. In applications where appearance is especially important, individual wrapping should be left intact until installation to minimize exposure to job-site conditions.

Beams are commonly loaded and unloaded with forklifts. For greater stability, the sides of the beams, rather than the bottoms, should rest on the forks. Supporting extremely long beams on their sides, however, can cause them to flex excessively, increasing the risk of damage. Use multiple forklifts to lift long beam members.

A level, well-drained, covered storage site is recommended. **Keep beams off the ground, using lumber blocking, skids, or a rack system. Keep beams level.** The wrapping on beams should be left in place to protect them from moisture, soiling, sunlight, and scratches. For long-term storage, cut slits in the bottom of the wrapping to allow ventilation and draining of any entrapped moisture. Proper ventilation and drainage will reduce the likelihood of water damage, staining, and the start of decay.

## DIMENSIONAL TOLERANCES

The tolerances permitted at the time of manufacture per ANSI Standard A190.1-92 are as follows:

- Width** – Plus or minus  $\frac{1}{16}$ " of the specified width.
- Depth** – Plus  $\frac{1}{8}$ " per foot of depth. Minus  $\frac{3}{16}$ ", or  $\frac{1}{16}$ " per foot of depth, whichever is larger.
- Length** – **Up to 20 feet** – Plus or minus  $\frac{1}{16}$ "  
**Over 20 feet** – Plus or minus  $\frac{1}{16}$ " per 20 feet of length.

Tolerances do not apply to textured beams – see AITC 113-2001.

**Camber or Straightness** – Tolerances are intended for use with straight or slightly cambered beams. The tolerances permitted at the time of manufacture, without allowance for dead load deflection, are as follows:

- Up to 20 feet** – Plus or minus  $\frac{1}{4}$ ".
- Over 20 feet** – Add  $\frac{1}{8}$ " per each additional 20 feet or fraction thereof, but not to exceed plus or minus  $\frac{3}{4}$ ".

**Squareness** – The tolerance of the cross section shall be within plus or minus  $\frac{1}{8}$ " per foot of specified depth, unless a specially shaped beam is selected.

## EXPOSED APPLICATIONS FOR GLULAM

BOISE GLULAM® beams are intended for applications where mold, decay, and/or insect attack are not concerns. For conditions where glulams are permanently exposed to the weather, have direct ground or concrete contact, or are exposed to significant moisture from condensation or other sources, preservative treatment is required as specified by applicable building codes. For information on different treatments for specific applications, please consult a wood treater or treating association. Please note that when glulams are treated, design values may be affected.

All field cuts – including notches, end cuts, and holes—should be performed before the glulam beam is treated. All fasteners used with treated glulam beams must be resistant to corrosion from moisture.

Consumer Information Sheets that detail proper use and handling of products with the specified treatments should be obtained from the treater for proper use and handling of products with the specified treatments. In addition, Material Safety Data Sheets (MSDS) and OSHA-required hazard labels provided with each preservative should be reviewed. Please note that when glulams are treated and installed in exterior applications, design values shall be adjusted per building code provisions.

Durable species glulams such as Alaska Yellow Cedar are readily available and provide alternative product for exposed applications. This may be a good option for your top appearance applications. Consult your local distributor for availability.

## FIRE RESISTANCE

BOISE GLULAM® beams, like many other wood products, have advantageous fire-endurance properties. Unlike steel that loses a large percentage of its strength when exposed to typical temperatures during a fire, wood beams char on the surface. Charring forms a self-insulating surface layer when wood is exposed to flame or relatively high temperatures. The wood below this layer retains its structural properties during a fire. Most solid wood members, including BOISE GLULAM® beams, char at a rate of approximately  $1\frac{1}{2}$  inches per hour. BOISE GLULAM® may be special ordered to create a beam with a one-hour fire rating. In this beam specification, an additional high grade tension lamination replaces a core lamination in the manufacturing process. The project's design professional of record shall specify this type of fire-resistance requirement.

Larger glulam beams may be utilized in heavy timber construction, and a fire-resistance classification where exposed beams are designed to maintain a specified strength level for a specified duration during a fire. For further information on heavy timber construction, please refer to *Standard for Heavy Timber Construction*, AITC 108.

The adhesives used in BOISE GLULAM® beams do not reduce the fire-endurance properties of the wood material. When compared to wood, the adhesives have a higher ignition temperature and char in a very similar manner. When burned, the adhesives do not increase smoke toxicity. For further information on fire-resistance design, please contact Boise Cascade EWP Engineering.

## FIELD NOTCHING & DRILLING

Glulam beams are generally designed for applications where they will be highly stressed under design loads. For this reason, field modifications such as notching, tapering, or drilling may only be made only after approval has been given by the project's design professional of record and/or Boise Engineered Wood Products representative. For the proper location of smaller holes, please refer to page 8. Analysis of notches and tapered end cuts on BOISE GLULAM® beams may be performed by a qualified user of BC CALC®, Boise EWP's engineered wood sizing software.

## BOISE GLULAM® Manufacturing Standards

AITC Mill Number: 220

City of Los Angeles

Fabricator License: 01365

# Allowable Design Values & Stresses, Section Properties

## BOISE GLULAM® 24F-V4 Design Values

Width (in)	Depth (in)	Weight (plf)	Allowable Shear (lbs)	Allowable Moment (ft-lbs)	Moment of Inertia (in <sup>4</sup> )
3 <sup>1</sup> / <sub>8</sub>	6	4.6	3313	3750	56.3
	7 <sup>1</sup> / <sub>2</sub>	5.7	4141	5859	109.9
	9	6.8	4969	8438	189.8
	10 <sup>1</sup> / <sub>2</sub>	8.0	5797	11484	301.5
	12	9.1	6625	15000	450.0
	13 <sup>1</sup> / <sub>2</sub>	10.3	7453	18984	640.7
	15	11.4	8281	23438	878.9
	16 <sup>1</sup> / <sub>2</sub>	12.5	9109	28359	1169.8
	18	13.7	9938	33750	1518.8
3 <sup>1</sup> / <sub>2</sub>	4 <sup>1</sup> / <sub>2</sub>	3.8	2783	2363	26.6
	6	5.1	3710	4200	63.0
	7 <sup>1</sup> / <sub>2</sub>	6.4	4638	6563	123.0
	9	7.7	5565	9450	212.6
	10 <sup>1</sup> / <sub>2</sub>	8.9	6493	12863	337.6
	12	10.2	7420	16800	504.0
	13 <sup>1</sup> / <sub>2</sub>	11.5	8348	21263	717.6
	15	12.8	9275	26250	984.4
5 <sup>1</sup> / <sub>8</sub>	6	7.5	5433	6150	92.3
	7 <sup>1</sup> / <sub>2</sub>	9.3	6791	9609	180.2
	9	11.2	8149	13838	311.3
	10 <sup>1</sup> / <sub>2</sub>	13.1	9507	18834	494.4
	12	14.9	10865	24600	738.0
	13 <sup>1</sup> / <sub>2</sub>	16.8	12223	30770	1050.8
	15	18.7	13581	37589	1441.4
	16 <sup>1</sup> / <sub>2</sub>	20.6	14939	45052	1918.5
	18	22.4	16298	53151	2490.8
	19 <sup>1</sup> / <sub>2</sub>	24.3	17656	61881	3166.8
	21	26.2	19014	71237	3955.2
	22 <sup>1</sup> / <sub>2</sub>	28.0	20372	81215	4864.7
	24	29.9	21730	91810	5904.0

Width (in)	Depth (in)	Weight (plf)	Allowable Shear (lbs)	Allowable Moment (ft-lbs)	Moment of Inertia (in <sup>4</sup> )
5 <sup>1</sup> / <sub>2</sub>	9	12.0	8745	14850	334.1
	10 <sup>1</sup> / <sub>2</sub>	14.0	10203	20213	530.6
	12	16.0	11660	26214	792.0
	13 <sup>1</sup> / <sub>2</sub>	18.0	13118	32789	1127.7
	15	20.1	14575	40056	1546.9
6 <sup>3</sup> / <sub>4</sub>	7 <sup>1</sup> / <sub>2</sub>	12.3	8944	12656	237.3
	9	14.8	10733	18225	410.1
	10 <sup>1</sup> / <sub>2</sub>	17.2	12521	24457	651.2
	12	19.7	14310	31520	972.0
	13 <sup>1</sup> / <sub>2</sub>	22.1	16099	39425	1384.0
	15	24.6	17888	48163	1898.4
	16 <sup>1</sup> / <sub>2</sub>	27.1	19676	57724	2526.8
	18	29.5	21465	68102	3280.5
8 <sup>3</sup> / <sub>4</sub>	19 <sup>1</sup> / <sub>2</sub>	32.0	23254	79288	4170.9
	21	34.5	25043	91276	5209.3
	22 <sup>1</sup> / <sub>2</sub>	36.9	26831	104061	6407.2
	24	39.4	28620	117636	7776.0
	9	19.1	13913	23048	531.6
	10 <sup>1</sup> / <sub>2</sub>	22.3	16231	30891	844.1
	12	25.5	18550	39812	1260.0
	13 <sup>1</sup> / <sub>2</sub>	28.7	20869	49798	1794.0
	15	31.9	23188	60834	2460.9
	16 <sup>1</sup> / <sub>2</sub>	35.1	25506	72911	3275.5
18	38.3	27825	86018	4252.5	
19 <sup>1</sup> / <sub>2</sub>	41.5	30144	100147	5406.7	
21	44.7	32463	115290	6752.8	
22 <sup>1</sup> / <sub>2</sub>	47.9	34781	131438	8305.7	
24	51.0	37100	148585	10080.0	

### Notes:

1) Allowable moment calculated using glulam volume factor ( $C_v$ ) with a span length of 21 ft. Allowable moment shall be multiplied by  $(21/\text{Span Length [ft]})^{1/10}$  for longer spans.

## BOISE GLULAM® 24F-V4 Allowable Design Stresses

Bending $F_b$ [psi]		Horizontal Shear $F_v$ [psi]	Modulus of Elasticity $E$ [psi]	Tension Parallel to Grain $F_t$ [psi]	Compression Parallel to Grain $F_c$ [psi]	Compression Perpendicular to Grain $F_c$ [psi]
Tension Zone in Tension	Compression Zone in Tension					
<b>2400</b>	<b>1850</b>	<b>265</b>	<b>1,800,000</b>	<b>1100</b>	<b>1650</b>	<b>650</b>

### Notes:

The data is for stock beams. For information on sizes not listed, please use BC CALC® software or consult with Boise EWP Engineering.

Designer of record shall review the glulam's application and consider the conditions of use. Contact Boise Cascade EWP Engineering for non-standard application design stresses and reduction factors for wet-use and stability conditions.

# Column Table & Allowable Stresses

## BOISE GLULAM® COLUMNS

Allowable Axial Load — Combination 3 Column Grade

Column Length [ft]	3 1/8" Wide Column Allowable Axial Load (lb)						5 1/8" Wide Column Allowable Axial Load (lb)								
	3 1/8" x 6"			3 1/8" x 7 1/2"			5 1/8" x 5 1/8"			5 1/8" x 6"			5 1/8" x 7 1/2"		
	100%	115%	125%	100%	115%	125%	100%	115%	125%	100%	115%	125%	100%	115%	125%
4	20,200	22,160	23,340	25,260	27,710	29,180	31,380	35,530	38,170						
5	16,940	18,150	18,850	21,180	22,690	23,570	29,520	33,080	35,340	35,890	40,450	43,330			
6	13,890	14,650	15,090	17,370	18,320	18,860	27,360	30,300	32,110	33,760	37,640	39,950			
7	11,400	11,920	12,210	14,260	14,890	15,270	24,990	27,300	28,690	31,060	33,850	35,520	34,870	37,470	38,990
8	9,460	9,820	10,030	11,830	12,280	12,530	22,530	24,270	25,290	27,870	29,960	31,180	30,990	32,950	34,080
9	7,940	8,210	8,360	9,930	10,260	10,450	20,110	21,440	22,210	24,780	26,340	27,250	27,470	28,960	29,830
10	6,750	6,950	7,060	8,440	8,690	8,830	17,900	18,920	19,520	21,970	23,160	23,850	24,380	25,550	26,220
11	5,800	5,950	6,040	7,250	7,440	7,550	15,940	16,760	17,230	19,490	20,430	20,970	21,700	22,640	23,190
12	5,030	5,150	5,220	6,290	6,440	6,530	14,240	14,900	15,280	17,350	18,110	18,530	19,400	20,160	20,600
13	4,400	4,500	4,550	5,500	5,620	5,698	12,770	13,310	13,610	15,520	16,120	16,480	17,420	18,050	18,410
14							11,500	11,940	12,200	13,930	14,440	14,720	15,720	16,240	16,540
15							10,400	10,770	10,980	12,570	12,980	13,220	14,240	14,670	14,930
16							9,440	9,750	9,930	11,380	11,740	11,930	12,950	13,320	13,530
17							8,600	8,860	9,010	10,350	10,650	10,820	11,820	12,140	12,320
18							7,860	8,090	8,220	9,450	9,710	9,850	10,830	11,110	11,270
19							7,220	7,410	7,520	8,660	8,880	9,010	9,960	10,200	10,340
20							6,640	6,810	6,910	7,960	8,160	8,260	9,190	9,390	9,510
21							6,130	6,280	6,370	7,340	7,510	7,610	8,580	8,780	8,900
22															
23															
24															

Column Length [ft]	6 3/4" Wide Column Allowable Axial Load (lb)						8 3/4" Wide Column Allowable Axial Load (lb)			<b>Notes:</b> 1) Table assumes that the column is braced at column ends only. Effective column length is equal to actual column length. 2) Allowable loads are based on one-piece column members used in dry service conditions. 3) Allowable loads are based on an eccentricity value equal to 0.167 multiplied by the column thickness or width (worst case). 4) Allowable loads are based on axial loading columns using the design provisions of the National Design Specification for Wood Construction (NDS), 2001 edition. For side or other combined bending and axial loads, use BC COLUMN software to analyze such conditions. 5) See below for allowable design stresses. 6) Load values are not shown for short lengths due to loads exceeding common connector capacities. Load values are not shown for longer lengths if the controlling slenderness ratio exceeds 50 (per NDS). 7) It may be possible to exceed the limitations of the table by analyzing a specific application with the BC COLUMN software.
	6 3/4" x 6"			6 3/4" x 7 1/2"			8 3/4" x 9"			
	100%	115%	125%	100%	115%	125%	100%	115%	125%	
4										
5										
6										
7										
8										
9	35,920	38,870	40,620							
10	32,700	35,020	36,390							
11	29,620	31,470	32,540							
12	26,820	28,310	29,180	39,870	42,340	43,790				
13	24,310	25,530	26,240	36,390	38,420	39,600				
14	22,080	23,100	23,680	33,240	34,920	35,900				
15	20,100	20,960	21,460	30,410	31,830	32,640				
16	18,360	19,090	19,500	27,870	29,070	29,760				
17	16,820	17,440	17,800	25,620	26,650	27,230				
18	15,460	15,990	16,300	23,600	24,480	24,990				
19	14,250	14,710	14,970	21,800	22,570	23,000				
20	13,170	13,570	13,800	20,180	20,850	21,240				
21	12,200	12,550	12,750	18,730	19,320	19,650				
22	11,330	11,640	11,820	17,430	17,940	18,240	39,360	41,030	41,950	
23	10,550	10,820	10,980	16,250	16,710	16,970	36,940	38,400	39,250	
24	9,840	10,090	10,230	15,180	15,590	15,820	34,710	36,020	36,760	
25							32,660	33,830	34,510	
26							30,780	31,840	32,440	
27							29,060	30,010	30,560	
28							27,460	28,330	28,830	
29							26,000	26,780	27,240	
30							24,630	25,360	25,780	

## BOISE GLULAM® Column Allowable Design Stresses

Combination 3 Column Grade

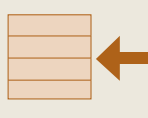
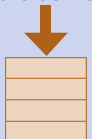
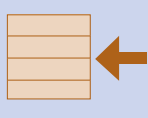
Compression Parallel to Grain $F_c$ [psi]	Bending $F_b$ [psi]		Modulus of Elasticity $E$ [psi]		Compression Perpendicular to Grain (limiting direction) $F_c$ [psi]	Tension Parallel to Grain $F_t$ [psi]
	Load Perpendicular to Gluelines	Load Parallel to Gluelines	Load Perpendicular to Gluelines	Load Parallel to Gluelines		
<b>2300</b>	 <b>2000</b>	 <b>2100</b>	 <b>1,900,000</b>	 <b>1,900,000</b>	<b>650</b>	<b>1450</b>

Equivalent specific gravity for fastener design: SG = 0.5.

## Horizontal Holes

### Allowable Holes in Glulam Beams

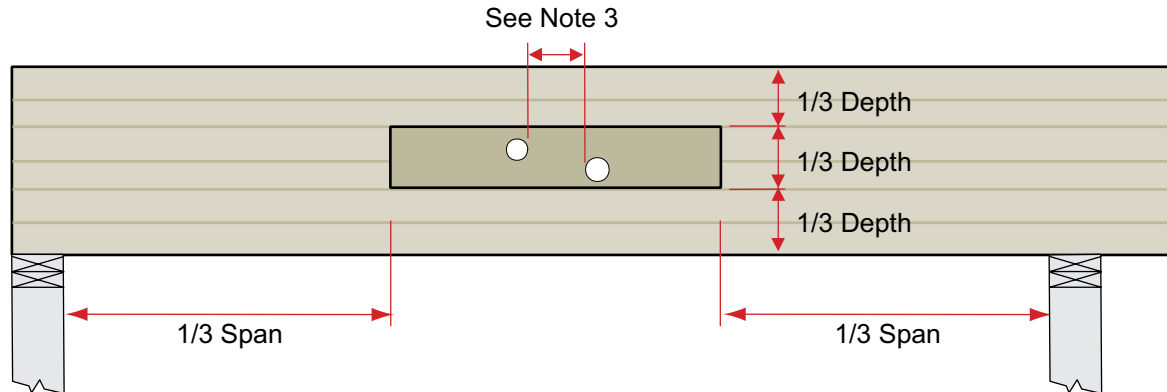

#### Notes:

- 1) Square and rectangular holes are not permitted.
- 2) Round holes may be drilled or cut with a hole saw anywhere within the shaded area of the beam.
- 3) The horizontal distance between adjacent holes shall be at least two times the diameter of the larger hole.
- 4) Do not drill more than three access holes in any 4-foot long section of beam.
- 5) The maximum round hole diameter permitted is:
 

Beam Depth	6" & 7 <sup>1</sup> / <sub>2</sub> "	9" & greater
Maximum Hole Diameter	1"	2"
- 6) These limitations apply to holes drilled for plumbing or wiring access only. The size and location of holes drilled for fasteners are governed by the provisions of the National Design Specification® for Wood Construction.
- 7) Beams deflect under load. Size holes to provide clearance where required.
- 8) This hole chart is valid for BOISE GLULAM® beams supporting uniform load only. For beams supporting concentrated loads or for beams with larger holes, contact Boise EWP Engineering.
- 9) For vertical holes, see page 28 for provisions with ridge beams or contact Boise EWP Engineering.



## Common Details

**G1** Beam Framing to Wall

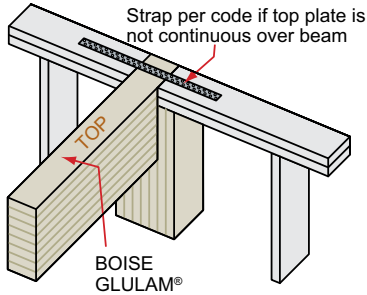

**G2** Beam Bearing for Header

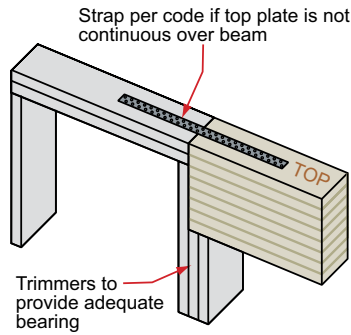

**G3** Beam to Wall with Lateral Support

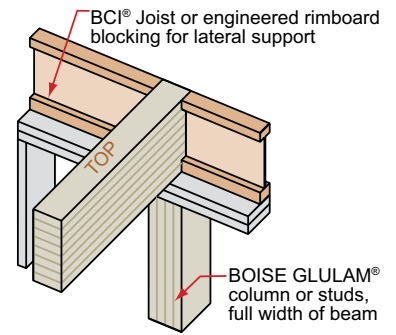

**G4** End Wall Bevel Plate

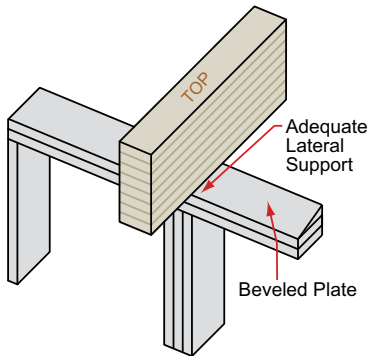

**G5** Beam to Beam Connection

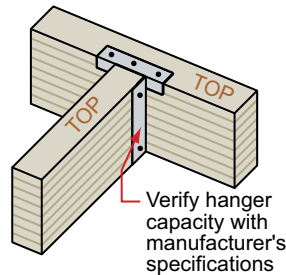

**G6** Beam to Concrete / Masonry Wall

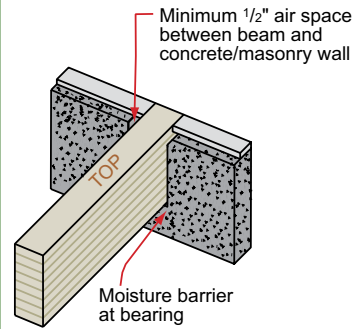

**G7** Beam to Column Connection

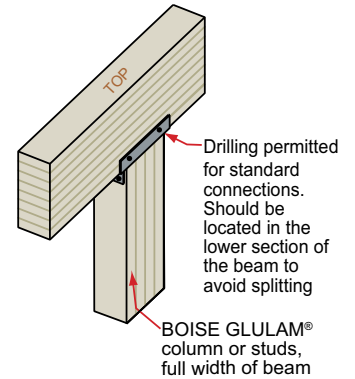

**G8** Beam Depth Change at Intermediate Support

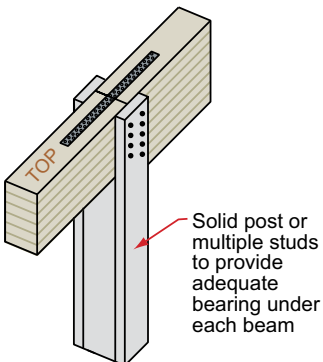

**G9** Sloped Seat Cut

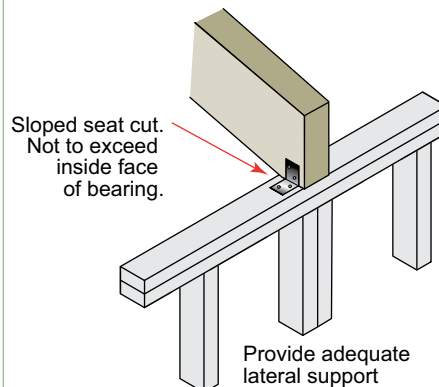

**G10** Bevel Cutting

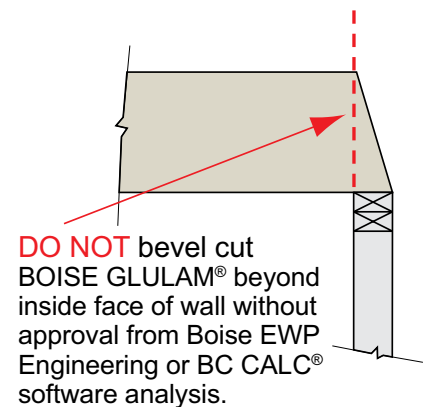

# BOISE GLULAM® Beams Floor Load Tables

## Architectural Appearance Beams

### 3 1/8" Floor Load Tables – 100%

Span [ft]	24F-V4 Grade – 100% Load Duration In pounds per lineal foot (PLF)									
	Span Type	6"	7.5"	9"	10.5"	12"	13.5"	15"	16.5"	18"
6	Simple	829	1296	1868	2544	3303	3965	4721	5593	6611
	Multiple	638	998	1438	1959	2400	2829	3301	3823	4403
	Min. Bearing	1.5 / 3	1.9 / 3.7	2.8 / 5.3	3.8 / 7.3	4.9 / 8.9	5.9 / 10.5	7 / 12.2	8.3 / 14.2	9.8 / 16.3
8	Simple	362	710	1048	1428	1866	2363	2918	3458	3961
	Multiple	357	559	806	1099	1436	1819	2197	2500	2826
	Min. Bearing	1.5 / 3	1.5 / 3	2.1 / 4	2.8 / 5.4	3.7 / 7.1	4.7 / 9	5.8 / 10.9	6.8 / 12.4	7.8 / 14
10	Simple	183	361	626	911	1191	1508	1864	2256	2686
	Multiple	227	356	513	700	916	1160	1434	1736	2068
	Min. Bearing	1.5 / 3	1.5 / 3	1.6 / 3.2	2.3 / 4.4	3 / 5.7	3.7 / 7.2	4.6 / 8.9	5.6 / 10.8	6.6 / 12.8
12	Simple	104	206	359	574	824	1044	1291	1563	1861
	Multiple	138	245	354	484	633	803	992	1202	1432
	Min. Bearing	1.5 / 3	1.5 / 3	1.5 / 3	1.7 / 3.6	2.5 / 4.7	3.1 / 6	3.8 / 7.4	4.7 / 9	5.5 / 10.7
14	Simple	64	128	224	358	538	765	945	1145	1364
	Multiple	85	170	259	353	463	587	726	880	1048
	Min. Bearing	1.5 / 3	1.5 / 3	1.5 / 3	1.5 / 3.1	1.9 / 4.1	2.7 / 5.1	3.3 / 6.4	4 / 7.7	4.7 / 9.1
16	Simple	-	84	148	237	357	511	704	874	1041
	Multiple	-	112	196	269	352	447	553	671	799
	Min. Bearing	-	1.5 / 3	1.5 / 3	1.5 / 3	1.5 / 3.6	2.1 / 4.5	2.8 / 5.6	3.5 / 6.7	4.2 / 8
18	Simple	-	57	102	164	248	356	491	656	820
	Multiple	-	77	136	211	276	351	435	527	629
	Min. Bearing	-	1.5 / 3	1.5 / 3	1.5 / 3	1.5 / 3.2	1.6 / 4	2.2 / 4.9	3 / 6	3.7 / 7.1
20	Simple	-	-	72	118	178	257	355	475	619
	Multiple	-	-	97	157	222	282	350	425	507
	Min. Bearing	-	-	1.5 / 3	1.5 / 3	1.5 / 3	1.5 / 3.6	1.8 / 4.4	2.4 / 5.4	3.1 / 6.4
22	Simple	-	-	53	86	132	190	264	354	462
	Multiple	-	-	71	116	176	232	287	349	416
	Min. Bearing	-	-	1.5 / 3	1.5 / 3	1.5 / 3	1.5 / 3.3	1.5 / 4	2 / 4.9	2.6 / 5.8
24	Simple	-	-	-	65	99	144	201	270	353
	Multiple	-	-	-	88	134	193	240	291	346
	Min. Bearing	-	-	-	1.5 / 3	1.5 / 3	1.5 / 3	1.5 / 3.7	1.7 / 4.5	2.2 / 5.3
26	Simple	-	-	-	-	76	111	155	209	274
	Multiple	-	-	-	-	103	150	202	245	290
	Min. Bearing	-	-	-	-	1.5 / 3	1.5 / 3	1.5 / 3.4	1.5 / 4.1	1.8 / 4.9
28	Simple	-	-	-	-	59	87	122	165	217
	Multiple	-	-	-	-	81	118	164	208	247
	Min. Bearing	-	-	-	-	1.5 / 3	1.5 / 3	1.5 / 3	1.5 / 3.8	1.6 / 4.5
30	Simple	-	-	-	-	-	69	97	132	174
	Multiple	-	-	-	-	-	94	131	177	211
	Min. Bearing	-	-	-	-	-	1.5 / 3	1.5 / 3	1.5 / 3.5	1.5 / 4.2
32	Simple	-	-	-	-	-	55	78	106	141
	Multiple	-	-	-	-	-	75	106	144	183
	Min. Bearing	-	-	-	-	-	1.5 / 3	1.5 / 3	1.5 / 3.1	1.5 / 3.9
34	Simple	-	-	-	-	-	-	63	87	115
	Multiple	-	-	-	-	-	-	87	118	156
	Min. Bearing	-	-	-	-	-	-	1.5 / 3	1.5 / 3	1.5 / 3.5
36	Simple	-	-	-	-	-	-	51	71	95
	Multiple	-	-	-	-	-	-	71	97	129
	Min. Bearing	-	-	-	-	-	-	1.5 / 3	1.5 / 3	1.5 / 3.2
38	Simple	-	-	-	-	-	-	-	59	79
	Multiple	-	-	-	-	-	-	-	81	108
	Min. Bearing	-	-	-	-	-	-	-	1.5 / 3	1.5 / 3
40	Simple	-	-	-	-	-	-	-	-	65
	Multiple	-	-	-	-	-	-	-	-	90
	Min. Bearing	-	-	-	-	-	-	-	-	1.5 / 3

- Both Architectural and Industrial appearance grade BOISE GLULAMS™ have the same structural grade, 24F-V4. Appearance grade does not affect the beam's load capacity.
- Uniform PLF load values are limited by shear, moment, total load deflection limited to L/240 and live load deflection limited to L/360.
- Live load is equal to 0.8 of total load (residential loading).
- Span is measured center to center of the supports.
- Table values assume that lateral support is provided at each support and continuously along the compression edge of the beam.

- Table values for Minimum Required Bearing Lengths are based on the allowable compression design value perpendicular to grain for the beam and the load value shown. Other design considerations, such as a weaker support material, may warrant longer bearing lengths. Table values assume that support is provided across the full width of the beam.
- This table was designed to apply to a broad range of applications. It may be possible to exceed the limitations of this table by analyzing a specific application with the BC CALC® software.

# BOISE GLULAM® Beams Floor Load Tables

## Architectural Appearance Beams 5 1/8" Floor Load Tables – 100%

Span [ft]	24F-V4 Grade – 100% Load Duration In pounds per lineal foot (PLF)													
	Span Type	6"	7.5"	9"	10.5"	12"	13.5"	15"	16.5"	18"	19.5"	21"	22.5"	24"
6	Simple	1359	2126	3064	4172	5418	6502	7742	9173	10843	12816			
	Multiple	1046	1637	2359	3213	3936	4640	5414	6270	7221	8284			
	Min. Bearing	1.5 / 3	1.9 / 3.7	2.8 / 5.3	3.8 / 7.3	4.9 / 8.9	5.9 / 10.5	7 / 12.2	8.3 / 14.2	9.8 / 16.3	11.6 / 18.7			
8	Simple	593	1164	1718	2341	3060	3875	4786	5671	6497	7410	8424	9559	
	Multiple	585	917	1322	1802	2355	2983	3603	4101	4634	5207	5824	6491	
	Min. Bearing	1.5 / 3	1.5 / 3	2.1 / 4	2.8 / 5.4	3.7 / 7.1	4.7 / 9	5.8 / 10.9	6.8 / 12.4	7.8 / 14	8.9 / 15.7	10.1 / 17.6	11.5 / 19.6	
10	Simple	300	591	1027	1494	1953	2474	3056	3700	4406	5172	5824	6491	7213
	Multiple	372	583	842	1148	1502	1903	2352	2848	3391	3793	4199	4628	5083
	Min. Bearing	1.5 / 3	1.5 / 3	1.6 / 3.2	2.3 / 4.4	3 / 5.7	3.7 / 7.2	4.6 / 8.9	5.6 / 10.8	6.6 / 12.8	7.8 / 14.3	8.8 / 15.9	9.8 / 17.5	10.9 / 19.2
12	Simple	170	338	589	941	1352	1713	2117	2563	3053	3585	4159	4744	5364
	Multiple	227	402	581	793	1039	1316	1627	1971	2348	2758	3200	3594	3921
	Min. Bearing	1.5 / 3	1.5 / 3	1.5 / 3	1.7 / 3.6	2.5 / 4.7	3.1 / 6	3.8 / 7.4	4.7 / 9	5.5 / 10.7	6.5 / 12.5	7.5 / 14.5	8.6 / 16.3	9.7 / 17.8
14	Simple	105	210	367	588	882	1254	1550	1878	2237	2606	3002	3424	3873
	Multiple	140	279	424	579	759	963	1191	1443	1719	2003	2308	2633	2978
	Min. Bearing	1.5 / 3	1.5 / 3	1.5 / 3	1.5 / 3.1	1.9 / 4.1	2.7 / 5.1	3.3 / 6.4	4 / 7.7	4.7 / 9.1	5.5 / 10.7	6.4 / 12.3	7.3 / 14	8.2 / 15.8
16	Simple	68	137	242	389	586	838	1154	1426	1684	1963	2261	2580	2918
	Multiple	91	184	322	441	578	733	907	1095	1293	1507	1737	1982	2243
	Min. Bearing	1.5 / 3	1.5 / 3	1.5 / 3	1.5 / 3	1.5 / 3.6	2.1 / 4.5	2.8 / 5.6	3.5 / 6.7	4.1 / 7.9	4.8 / 9.2	5.5 / 10.6	6.3 / 12.1	7.1 / 13.6
18	Simple	-	94	167	270	407	584	805	1076	1310	1527	1760	2008	2272
	Multiple	-	126	223	345	453	576	708	850	1005	1172	1351	1542	1745
	Min. Bearing	-	1.5 / 3	1.5 / 3	1.5 / 3	1.5 / 3.2	1.6 / 4	2.2 / 4.9	3 / 5.9	3.6 / 6.9	4.2 / 8.1	4.8 / 9.3	5.5 / 10.6	6.2 / 12
20	Simple	-	66	119	193	293	421	582	779	1015	1219	1406	1604	1815
	Multiple	-	89	159	258	364	460	564	677	801	934	1077	1230	1392
	Min. Bearing	-	1.5 / 3	1.5 / 3	1.5 / 3	1.5 / 3.6	1.8 / 4.4	2.4 / 5.2	3.1 / 6.2	3.7 / 7.2	4.3 / 8.3	4.9 / 9.4	5.5 / 10.7	
22	Simple	-	-	86	142	216	312	433	580	757	967	1146	1308	1481
	Multiple	-	-	117	190	289	373	458	551	652	760	877	1002	1134
	Min. Bearing	-	-	1.5 / 3	1.5 / 3	1.5 / 3	1.5 / 3.2	1.5 / 3.9	2 / 4.7	2.6 / 5.6	3.3 / 6.5	3.9 / 7.5	4.4 / 8.5	5 / 9.6
24	Simple	-	-	64	106	163	237	329	442	578	739	928	1085	1228
	Multiple	-	-	88	144	219	308	378	455	539	629	726	830	940
	Min. Bearing	-	-	1.5 / 3	1.5 / 3	1.5 / 3	1.5 / 3	1.5 / 3.6	1.7 / 4.3	2.2 / 5.1	2.8 / 5.9	3.4 / 6.8	4 / 7.7	4.5 / 8.7
26	Simple	-	-	-	81	125	182	255	343	450	576	724	895	1034
	Multiple	-	-	-	110	169	245	317	382	452	528	610	697	790
	Min. Bearing	-	-	-	1.5 / 3	1.5 / 3	1.5 / 3	1.5 / 3.3	1.5 / 3.9	1.8 / 4.6	2.3 / 5.4	2.9 / 6.2	3.6 / 7.1	4.2 / 8
28	Simple	-	-	-	62	97	143	200	271	356	457	574	711	867
	Multiple	-	-	-	86	132	193	269	324	384	449	518	593	672
	Min. Bearing	-	-	-	1.5 / 3	1.5 / 3	1.5 / 3	1.5 / 3	1.5 / 3.6	1.6 / 4.3	2 / 5	2.5 / 5.7	3.1 / 6.5	3.8 / 7.4
30	Simple	-	-	-	-	76	113	159	216	285	367	462	573	699
	Multiple	-	-	-	-	105	154	215	277	329	385	445	509	577
	Min. Bearing	-	-	-	-	1.5 / 3	1.5 / 3	1.5 / 3	1.5 / 3.4	1.5 / 4	1.8 / 4.6	2.2 / 5.3	2.7 / 6	3.3 / 6.8
32	Simple	-	-	-	-	60	90	128	175	231	298	376	467	571
	Multiple	-	-	-	-	84	124	174	236	284	333	385	441	500
	Min. Bearing	-	-	-	-	1.5 / 3	1.5 / 3	1.5 / 3	1.5 / 3.1	1.5 / 3.7	1.5 / 4.3	1.9 / 4.9	2.4 / 5.6	2.9 / 6.4
34	Simple	-	-	-	-	-	72	104	142	189	244	309	385	471
	Multiple	-	-	-	-	-	100	142	193	248	290	336	385	437
	Min. Bearing	-	-	-	-	-	1.5 / 3	1.5 / 3	1.5 / 3	1.5 / 3.4	1.5 / 4	1.7 / 4.6	2.1 / 5.3	2.6 / 6
36	Simple	-	-	-	-	-	58	84	117	156	202	256	320	392
	Multiple	-	-	-	-	-	82	117	160	212	255	295	338	384
	Min. Bearing	-	-	-	-	-	1.5 / 3	1.5 / 3	1.5 / 3	1.5 / 3.2	1.5 / 3.8	1.5 / 4.3	1.9 / 4.9	2.3 / 5.6
38	Simple	-	-	-	-	-	-	69	96	129	168	214	267	329
	Multiple	-	-	-	-	-	-	96	133	177	225	261	299	340
	Min. Bearing	-	-	-	-	-	-	1.5 / 3	1.5 / 3	1.5 / 3	1.5 / 3.6	1.5 / 4.1	1.7 / 4.7	2 / 5.3
40	Simple	-	-	-	-	-	-	56	79	107	141	180	225	278
	Multiple	-	-	-	-	-	-	80	111	148	193	231	265	302
	Min. Bearing	-	-	-	-	-	-	1.5 / 3	1.5 / 3	1.5 / 3	1.5 / 3.3	1.5 / 3.9	1.5 / 4.4	1.8 / 5

- Both Architectural and Industrial appearance grade BOISE GLULAMS have the same structural grade, 24F-V4. Appearance grade does not affect the beam's load capacity.
- Uniform PLF load values are limited by shear, moment, total load deflection limited to L/240 and live load deflection limited to L/360.
- Live load is equal to 0.8 of total load (residential loading).
- Span is measured center to center of the supports.
- Table values assume that lateral support is provided at each support and continuously along the compression edge of the beam.
- Table values for Minimum Required Bearing Lengths are based on the allowable compression design value perpendicular to grain for the beam and the load value shown. Other design considerations, such as a weaker support material, may warrant longer bearing lengths. Table values assume that support is provided across the full width of the beam.
- This table was designed to apply to a broad range of applications. It may be possible to exceed the limitations of this table by analyzing a specific application with the BC CALC® software.

# BOISE GLULAM® Beams Floor Load Tables

## Architectural Appearance Beams 6¾" Floor Load Tables – 100%

### 24F-V4 Grade – 100% Load Duration In pounds per lineal foot (PLF)

Span [ft]	Span Type	24F-V4 Grade – 100% Load Duration In pounds per lineal foot (PLF)											
		7.5"	9"	10.5"	12"	13.5"	15"	16.5"	18"	19.5"	21"	22.5"	24"
6	Simple	2800	4035	5495	7135	8564	10197	12081	14280	16880			
	Multiple	2156	3107	4232	5184	6111	7130	8258	9510	10911			
	Min. Bearing	1.9 / 3.7	2.8 / 5.3	3.8 / 7.3	4.9 / 8.9	5.9 / 10.5	7 / 12.2	8.3 / 14.2	9.8 / 16.3	11.6 / 18.7			
8	Simple	1533	2263	3084	4030	5104	6304	7469	8556	9759	11096	12590	
	Multiple	1207	1741	2373	3102	3929	4745	5401	6103	6858	7671	8549	
	Min. Bearing	1.5 / 3	2.1 / 4	2.8 / 5.4	3.7 / 7.1	4.7 / 9	5.8 / 10.9	6.8 / 12.4	7.8 / 14	8.9 / 15.7	10.1 / 17.6	11.5 / 19.6	
10	Simple	779	1352	1967	2572	3258	4025	4873	5802	6800	7671	8549	9501
	Multiple	768	1109	1512	1978	2507	3097	3750	4466	4996	5531	6096	6695
	Min. Bearing	1.5 / 3	1.6 / 3.2	2.3 / 4.4	3 / 5.7	3.7 / 7.2	4.6 / 8.9	5.6 / 10.8	6.6 / 12.8	7.8 / 14.3	8.8 / 15.9	9.8 / 17.5	10.9 / 19.2
12	Simple	445	776	1239	1780	2256	2788	3364	3972	4626	5328	6077	6872
	Multiple	530	766	1045	1368	1734	2143	2587	3055	3559	4099	4676	5164
	Min. Bearing	1.5 / 3	1.5 / 3	1.7 / 3.6	2.5 / 4.7	3.1 / 6	3.8 / 7.4	4.6 / 8.9	5.5 / 10.5	6.4 / 12.3	7.3 / 14.1	8.4 / 16.1	9.5 / 17.8
14	Simple	276	483	774	1161	1652	2023	2427	2865	3338	3845	4386	4961
	Multiple	367	559	763	1000	1268	1553	1864	2202	2566	2956	3373	3815
	Min. Bearing	1.5 / 3	1.5 / 3	1.5 / 3.1	1.9 / 4.1	2.7 / 5.1	3.3 / 6.3	3.9 / 7.5	4.6 / 8.9	5.4 / 10.4	6.2 / 11.9	7.1 / 13.6	8 / 15.4
16	Simple	181	319	513	771	1104	1520	1827	2157	2514	2897	3305	3738
	Multiple	242	424	580	761	954	1168	1402	1656	1931	2225	2539	2872
	Min. Bearing	1.5 / 3	1.5 / 3	1.5 / 3	1.5 / 3.6	2.1 / 4.4	2.8 / 5.4	3.4 / 6.5	4 / 7.7	4.6 / 8.9	5.3 / 10.3	6.1 / 11.7	6.9 / 13.3
18	Simple	123	220	355	536	769	1060	1417	1678	1956	2254	2572	2910
	Multiple	166	293	455	590	740	906	1089	1287	1501	1730	1974	2234
	Min. Bearing	1.5 / 3	1.5 / 3	1.5 / 3	1.5 / 3.1	1.6 / 3.9	2.2 / 4.8	3 / 5.7	3.5 / 6.8	4.1 / 7.9	4.7 / 9	5.4 / 10.3	6.1 / 11.7
20	Simple	87	156	254	385	555	766	1026	1337	1562	1800	2054	2325
	Multiple	118	210	340	469	589	722	867	1026	1196	1380	1575	1783
	Min. Bearing	1.5 / 3	1.5 / 3	1.5 / 3	1.5 / 3	1.5 / 3.5	1.8 / 4.3	2.4 / 5.1	3.1 / 6	3.6 / 7	4.2 / 8.1	4.8 / 9.2	5.4 / 10.4
22	Simple	62	114	187	285	411	570	764	997	1272	1467	1675	1896
	Multiple	85	154	251	380	478	586	705	834	974	1123	1283	1452
	Min. Bearing	1.5 / 3	1.5 / 3	1.5 / 3	1.5 / 3	1.5 / 3.1	1.5 / 3.8	2 / 4.6	2.6 / 5.4	3.3 / 6.3	3.8 / 7.3	4.3 / 8.3	4.9 / 9.4
24	Simple	-	84	140	215	312	433	582	761	974	1216	1389	1573
	Multiple	-	115	189	289	394	484	583	690	806	930	1062	1203
	Min. Bearing	-	1.5 / 3	1.5 / 3	1.5 / 3	1.5 / 3	1.5 / 3.5	1.7 / 4.2	2.2 / 4.9	2.8 / 5.7	3.4 / 6.6	3.9 / 7.5	4.4 / 8.5
26	Simple	-	63	106	165	240	335	452	593	759	954	1169	1323
	Multiple	-	88	145	223	323	405	488	579	676	781	892	1011
	Min. Bearing	-	1.5 / 3	1.5 / 3	1.5 / 3	1.5 / 3	1.5 / 3.2	1.5 / 3.8	1.8 / 4.5	2.3 / 5.2	2.9 / 6	3.6 / 6.9	4 / 7.8
28	Simple	-	-	82	128	188	264	357	469	601	757	936	1127
	Multiple	-	-	113	174	254	343	414	491	574	663	758	860
	Min. Bearing	-	-	1.5 / 3	1.5 / 3	1.5 / 3	1.5 / 3	1.5 / 3.5	1.6 / 4.2	2 / 4.8	2.5 / 5.6	3.1 / 6.3	3.7 / 7.2
30	Simple	-	-	63	100	149	210	285	375	483	609	754	921
	Multiple	-	-	89	138	203	284	355	421	492	569	651	738
	Min. Bearing	-	-	1.5 / 3	1.5 / 3	1.5 / 3	1.5 / 3	1.5 / 3.3	1.5 / 3.8	1.8 / 4.5	2.2 / 5.2	2.7 / 5.9	3.3 / 6.6
32	Simple	-	-	-	79	119	169	230	304	392	495	615	752
	Multiple	-	-	-	110	163	229	306	364	426	493	564	640
	Min. Bearing	-	-	-	1.5 / 3	1.5 / 3	1.5 / 3	1.5 / 3	1.5 / 3.6	1.5 / 4.2	1.9 / 4.8	2.4 / 5.5	2.9 / 6.2
34	Simple	-	-	-	63	95	136	187	249	322	407	506	620
	Multiple	-	-	-	89	132	187	255	317	371	430	492	559
	Min. Bearing	-	-	-	1.5 / 3	1.5 / 3	1.5 / 3	1.5 / 3	1.5 / 3.4	1.5 / 3.9	1.7 / 4.5	2.1 / 5.1	2.6 / 5.8
36	Simple	-	-	-	-	77	111	153	205	266	338	421	516
	Multiple	-	-	-	-	108	154	210	278	325	377	432	491
	Min. Bearing	-	-	-	-	1.5 / 3	1.5 / 3	1.5 / 3	1.5 / 3.1	1.5 / 3.7	1.5 / 4.2	1.9 / 4.8	2.3 / 5.4
38	Simple	-	-	-	-	62	91	126	170	221	282	352	433
	Multiple	-	-	-	-	88	127	175	233	287	333	382	434
	Min. Bearing	-	-	-	-	1.5 / 3	1.5 / 3	1.5 / 3	1.5 / 3	1.5 / 3.5	1.5 / 4	1.7 / 4.5	2 / 5.1
40	Simple	-	-	-	-	-	74	105	141	185	237	297	366
	Multiple	-	-	-	-	-	105	146	195	254	295	339	386
	Min. Bearing	-	-	-	-	-	1.5 / 3	1.5 / 3	1.5 / 3	1.5 / 3.3	1.5 / 3.8	1.5 / 4.3	1.8 / 4.8

- Both Architectural and Industrial appearance grade BOISE GLULAMS have the same structural grade, 24F-V4. Appearance grade does not affect the beam's load capacity.
- Uniform PLF load values are limited by shear, moment, total load deflection limited to L/240 and live load deflection limited to L/360.
- Live load is equal to 0.8 of total load (residential loading).
- Span is measured center to center of the supports.
- Table values assume that lateral support is provided at each support and continuously along the compression edge of the beam.
- Table values for Minimum Required Bearing Lengths are based on the allowable compression design value perpendicular to grain for the beam and the load value shown. Other design considerations, such as a weaker support material, may warrant longer bearing lengths. Table values assume that support is provided across the full width of the beam.
- This table was designed to apply to a broad range of applications. It may be possible to exceed the limitations of this table by analyzing a specific application with the BC CALC® software.

# BOISE GLULAM® Beams Floor Load Tables

## Architectural Appearance Beams 8 3/4" Floor Load Tables – 100%

Span [ft]	24F-V4 Grade – 100% Load Duration In pounds per lineal foot (PLF)											
	Span Type	9"	10.5"	12"	13.5"	15"	16.5"	18"	19.5"	21"	22.5"	24"
6	Simple	5231	7124	9249	11101	13218	15661	18512	21881	25925	30869	37049
	Multiple	4028	5486	6720	7921	9243	10704	12328	14144	16187	18502	21149
	Min. Bearing	2.8 / 5.3	3.8 / 7.3	4.9 / 8.9	5.9 / 10.5	7 / 12.2	8.3 / 14.2	9.8 / 16.3	11.6 / 18.7	13.7 / 21.4	16.3 / 24.5	19.6 / 28
8	Simple	2934	3997	5224	6616	8171	9682	11092	12651	14383	16320	18499
	Multiple	2257	3076	4021	5093	6151	7001	7912	8890	9944	11082	12316
	Min. Bearing	2.1 / 4	2.8 / 5.4	3.7 / 7.1	4.7 / 9	5.8 / 10.9	6.8 / 12.4	7.8 / 14	8.9 / 15.7	10.1 / 17.6	11.5 / 19.6	13 / 21.7
10	Simple	1753	2550	3334	4224	5210	6247	7373	8587	9889	11082	12316
	Multiple	1438	1961	2564	3249	4008	4807	5675	6476	7169	7902	8678
	Min. Bearing	1.6 / 3.2	2.3 / 4.4	3 / 5.7	3.7 / 7.2	4.6 / 8.9	5.5 / 10.6	6.5 / 12.6	7.6 / 14.3	8.7 / 15.9	9.8 / 17.5	10.9 / 19.2
12	Simple	1006	1606	2308	2897	3542	4249	5016	5842	6729	7675	8679
	Multiple	993	1355	1773	2227	2723	3267	3857	4494	5177	5905	6678
	Min. Bearing	1.5 / 3	1.7 / 3.6	2.5 / 4.7	3.1 / 5.9	3.8 / 7.3	4.5 / 8.7	5.3 / 10.3	6.2 / 12	7.1 / 13.8	8.1 / 15.7	9.2 / 17.7
14	Simple	627	1003	1505	2088	2554	3064	3618	4215	4856	5539	6265
	Multiple	724	989	1279	1603	1961	2354	2780	3240	3733	4259	4817
	Min. Bearing	1.5 / 3	1.5 / 3.1	1.9 / 4	2.6 / 5	3.2 / 6.1	3.8 / 7.4	4.5 / 8.7	5.2 / 10.1	6 / 11.6	6.9 / 13.3	7.8 / 15
16	Simple	413	665	1000	1431	1922	2306	2724	3174	3657	4173	4720
	Multiple	550	742	960	1204	1474	1770	2091	2437	2809	3206	3627
	Min. Bearing	1.5 / 3	1.5 / 3	1.5 / 3.5	2.1 / 4.3	2.7 / 5.3	3.3 / 6.3	3.9 / 7.5	4.5 / 8.7	5.2 / 10	5.9 / 11.4	6.7 / 12.9
18	Simple	285	460	695	997	1375	1793	2119	2470	2846	3248	3675
	Multiple	380	575	744	934	1144	1374	1624	1894	2184	2493	2821
	Min. Bearing	1.5 / 3	1.5 / 3	1.5 / 3	1.6 / 3.8	2.2 / 4.7	2.9 / 5.6	3.4 / 6.6	4 / 7.7	4.6 / 8.8	5.2 / 10.1	5.9 / 11.4
20	Simple	202	329	499	719	993	1330	1691	1971	2272	2594	2935
	Multiple	272	440	591	743	911	1094	1294	1510	1741	1988	2251
	Min. Bearing	1.5 / 3	1.5 / 3	1.5 / 3	1.5 / 3.4	1.8 / 4.1	2.4 / 5	3 / 5.9	3.5 / 6.8	4.1 / 7.9	4.6 / 9	5.3 / 10.1
22	Simple	147	242	369	533	738	990	1293	1606	1852	2115	2394
	Multiple	200	325	479	603	740	890	1053	1229	1417	1619	1833
	Min. Bearing	1.5 / 3	1.5 / 3	1.5 / 3	1.5 / 3.1	1.5 / 3.7	2 / 4.5	2.6 / 5.3	3.2 / 6.1	3.7 / 7.1	4.2 / 8.1	4.7 / 9.1
24	Simple	109	181	278	404	561	755	987	1262	1535	1753	1985
	Multiple	149	245	374	497	611	735	870	1016	1173	1341	1519
	Min. Bearing	1.5 / 3	1.5 / 3	1.5 / 3	1.5 / 3	1.5 / 3.4	1.7 / 4.1	2.2 / 4.8	2.8 / 5.6	3.3 / 6.4	3.8 / 7.3	4.3 / 8.3
26	Simple	82	138	213	312	435	586	768	984	1236	1475	1670
	Multiple	113	188	289	416	511	616	730	853	985	1126	1276
	Min. Bearing	1.5 / 3	1.5 / 3	1.5 / 3	1.5 / 3	1.5 / 3.1	1.5 / 3.7	1.8 / 4.4	2.3 / 5.1	2.9 / 5.9	3.5 / 6.7	3.9 / 7.6
28	Simple	62	106	166	244	342	462	607	780	981	1213	1422
	Multiple	87	146	226	330	433	522	619	724	836	957	1085
	Min. Bearing	1.5 / 3	1.5 / 3	1.5 / 3	1.5 / 3	1.5 / 3	1.5 / 3.4	1.6 / 4	2 / 4.7	2.5 / 5.4	3.1 / 6.2	3.6 / 7
30	Simple	-	82	130	193	272	369	487	626	789	978	1193
	Multiple	-	115	179	263	368	447	530	621	718	821	931
	Min. Bearing	-	1.5 / 3	1.5 / 3	1.5 / 3	1.5 / 3	1.5 / 3.2	1.5 / 3.7	1.8 / 4.4	2.2 / 5	2.7 / 5.7	3.3 / 6.5
32	Simple	-	64	103	154	218	298	394	509	642	797	974
	Multiple	-	91	143	211	297	386	458	537	621	711	807
	Min. Bearing	-	1.5 / 3	1.5 / 3	1.5 / 3	1.5 / 3	1.5 / 3	1.5 / 3.5	1.5 / 4.1	1.9 / 4.7	2.4 / 5.3	2.9 / 6
34	Simple	-	-	81	123	177	243	322	417	528	657	804
	Multiple	-	-	115	171	243	330	399	468	541	620	704
	Min. Bearing	-	-	1.5 / 3	1.5 / 3	1.5 / 3	1.5 / 3	1.5 / 3.3	1.5 / 3.8	1.7 / 4.4	2.1 / 5	2.6 / 5.6
36	Simple	-	-	64	99	144	199	266	345	438	546	669
	Multiple	-	-	93	140	199	273	350	410	475	545	619
	Min. Bearing	-	-	1.5 / 3	1.5 / 3	1.5 / 3	1.5 / 3	1.5 / 3.1	1.5 / 3.6	1.5 / 4.1	1.9 / 4.7	2.3 / 5.3
38	Simple	-	-	51	80	118	164	220	287	366	457	561
	Multiple	-	-	75	115	165	227	301	362	419	481	547
	Min. Bearing	-	-	1.5 / 3	1.5 / 3	1.5 / 3	1.5 / 3	1.5 / 3	1.5 / 3.4	1.5 / 3.9	1.7 / 4.4	2 / 5
40	Simple	-	-	-	65	96	136	183	240	307	385	474
	Multiple	-	-	-	94	137	189	253	320	372	427	486
	Min. Bearing	-	-	-	1.5 / 3	1.5 / 3	1.5 / 3	1.5 / 3	1.5 / 3.2	1.5 / 3.7	1.5 / 4.2	1.8 / 4.7

- Both Architectural and Industrial appearance grade BOISE GLULAMS have the same structural grade, 24F-V4. Appearance grade does not affect the beam's load capacity.
- Uniform PLF load values are limited by shear, moment, total load deflection limited to L/240 and live load deflection limited to L/360.
- Live load is equal to 0.8 of total load (residential loading).
- Span is measured center to center of the supports.
- Table values assume that lateral support is provided at each support and continuously along the compression edge of the beam.

- Table values for Minimum Required Bearing Lengths are based on the allowable compression design value perpendicular to grain for the beam and the load value shown. Other design considerations, such as a weaker support material, may warrant longer bearing lengths. Table values assume that support is provided across the full width of the beam.
- This table was designed to apply to a broad range of applications. It may be possible to exceed the limitations of this table by analyzing a specific application with the BC CALC® software.

# BOISE GLULAM® Beams Floor Load Tables

## Industrial Appearance Headers 3 1/2" and 5 1/2" Floor Load Tables – 100%

**24F-V4 Grade – 100% Load Duration**  
In pounds per lineal foot (PLF)

Span [ft]	Span Type	3 1/2"								5 1/2"				
		4.5"	6"	7.5"	9"	10.5"	12"	13.5"	15"	9"	10.5"	12"	13.5"	15"
		6	Simple	406	928	1452	2092	2849	3700	4441	5287	3288	4478	5814
	Multiple	401	714	1118	1611	2194	2688	3169	3697	2532	3448	4224	4979	5810
	Min. Bearing	1.5 / 3	1.5 / 3	1.9 / 3.7	2.8 / 5.3	3.8 / 7.3	4.9 / 8.9	5.9 / 10.5	7 / 12.2	2.8 / 5.3	3.8 / 7.3	4.9 / 8.9	5.9 / 10.5	7 / 12.2
8	Simple	169	405	795	1174	1599	2090	2646	3268	1844	2513	3284	4159	5136
	Multiple	224	400	626	903	1230	1609	2037	2461	1419	1934	2528	3201	3867
	Min. Bearing	1.5 / 3	1.5 / 3	1.5 / 3	2.1 / 4	2.8 / 5.4	3.7 / 7.1	4.7 / 9	5.8 / 10.9	2.1 / 4	2.8 / 5.4	3.7 / 7.1	4.7 / 9	5.8 / 10.9
10	Simple	85	205	404	701	1020	1334	1690	2087	1102	1603	2096	2655	3280
	Multiple	113	254	398	575	784	1026	1300	1606	904	1232	1612	2042	2524
	Min. Bearing	1.5 / 3	1.5 / 3	1.5 / 3	1.6 / 3.2	2.3 / 4.4	3 / 5.7	3.7 / 7.2	4.6 / 8.9	1.6 / 3.2	2.3 / 4.4	3 / 5.7	3.7 / 7.2	4.6 / 8.9
12	Simple	-	116	231	403	642	923	1170	1446	633	1009	1451	1838	2272
	Multiple	-	155	275	397	542	709	899	1111	624	852	1115	1413	1746
	Min. Bearing	-	1.5 / 3	1.5 / 3	1.5 / 3	1.7 / 3.6	2.5 / 4.7	3.1 / 6	3.8 / 7.4	1.5 / 3	1.7 / 3.6	2.5 / 4.7	3.1 / 6	3.8 / 7.4
14	Simple	-	71	143	251	401	602	856	1059	394	630	946	1346	1664
	Multiple	-	96	190	290	396	518	657	813	455	622	815	1033	1278
	Min. Bearing	-	1.5 / 3	1.5 / 3	1.5 / 3	1.5 / 3.1	1.9 / 4.1	2.7 / 5.1	3.3 / 6.4	1.5 / 3	1.5 / 3.1	1.9 / 4.1	2.7 / 5.1	3.3 / 6.4
16	Simple	-	-	94	165	266	400	573	788	260	418	628	900	1239
	Multiple	-	-	125	220	301	394	501	620	346	473	620	787	971
	Min. Bearing	-	-	1.5 / 3	1.5 / 3	1.5 / 3	1.5 / 3.6	2.1 / 4.5	2.8 / 5.6	1.5 / 3	1.5 / 3	1.5 / 3.6	2.1 / 4.5	2.8 / 5.5
18	Simple	-	-	64	114	184	278	399	550	179	289	437	626	864
	Multiple	-	-	86	152	236	310	393	487	239	371	486	616	754
	Min. Bearing	-	-	1.5 / 3	1.5 / 3	1.5 / 3	1.5 / 3.2	1.6 / 4	2.2 / 4.9	1.5 / 3	1.5 / 3	1.5 / 3.2	1.6 / 4	2.2 / 4.9
20	Simple	-	-	-	81	132	200	288	397	127	207	314	452	624
	Multiple	-	-	-	109	176	249	316	392	171	277	390	490	600
	Min. Bearing	-	-	-	1.5 / 3	1.5 / 3	1.5 / 3	1.5 / 3.6	1.8 / 4.4	1.5 / 3	1.5 / 3	1.5 / 3	1.5 / 3.6	1.8 / 4.3
22	Simple	-	-	-	59	97	148	213	295	93	152	232	335	464
	Multiple	-	-	-	80	130	197	259	322	126	204	310	398	488
	Min. Bearing	-	-	-	1.5 / 3	1.5 / 3	1.5 / 3	1.5 / 3.3	1.5 / 4	1.5 / 3	1.5 / 3	1.5 / 3	1.5 / 3.2	1.5 / 3.9
24	Simple	-	-	-	-	72	111	162	225	69	114	175	254	353
	Multiple	-	-	-	-	98	150	216	268	94	154	235	328	403
	Min. Bearing	-	-	-	-	1.5 / 3	1.5 / 3	1.5 / 3	1.5 / 3.7	1.5 / 3	1.5 / 3	1.5 / 3	1.5 / 3	1.5 / 3.6
26	Simple	-	-	-	-	55	85	125	174	51	87	134	196	273
	Multiple	-	-	-	-	75	116	168	225	71	118	182	263	338
	Min. Bearing	-	-	-	-	1.5 / 3	1.5 / 3	1.5 / 3	1.5 / 3.4	1.5 / 3	1.5 / 3	1.5 / 3	1.5 / 3	1.5 / 3.3
28	Simple	-	-	-	-	-	66	97	137	-	67	104	153	215
	Multiple	-	-	-	-	-	90	132	184	-	92	142	207	286
	Min. Bearing	-	-	-	-	-	1.5 / 3	1.5 / 3	1.5 / 3	-	1.5 / 3	1.5 / 3	1.5 / 3	1.5 / 3
30	Simple	-	-	-	-	-	52	77	109	-	51	82	121	171
	Multiple	-	-	-	-	-	72	105	147	-	72	113	165	231
	Min. Bearing	-	-	-	-	-	1.5 / 3	1.5 / 3	1.5 / 3	-	1.5 / 3	1.5 / 3	1.5 / 3	1.5 / 3
32	Simple	-	-	-	-	-	-	62	87	-	-	65	97	137
	Multiple	-	-	-	-	-	-	85	119	-	-	90	133	187
	Min. Bearing	-	-	-	-	-	-	1.5 / 3	1.5 / 3	-	-	1.5 / 3	1.5 / 3	1.5 / 3
34	Simple	-	-	-	-	-	-	-	71	-	-	51	78	111
	Multiple	-	-	-	-	-	-	-	97	-	-	72	108	152
	Min. Bearing	-	-	-	-	-	-	-	1.5 / 3	-	-	1.5 / 3	1.5 / 3	1.5 / 3
36	Simple	-	-	-	-	-	-	-	58	-	-	-	63	90
	Multiple	-	-	-	-	-	-	-	80	-	-	-	88	125
	Min. Bearing	-	-	-	-	-	-	-	1.5 / 3	-	-	-	1.5 / 3	1.5 / 3
38	Simple	-	-	-	-	-	-	-	-	-	-	-	50	74
	Multiple	-	-	-	-	-	-	-	-	-	-	-	72	104
	Min. Bearing	-	-	-	-	-	-	-	-	-	-	-	1.5 / 3	1.5 / 3
40	Simple	-	-	-	-	-	-	-	-	-	-	-	-	61
	Multiple	-	-	-	-	-	-	-	-	-	-	-	-	86
	Min. Bearing	-	-	-	-	-	-	-	-	-	-	-	-	1.5 / 3

- Both Architectural and Industrial appearance grade BOISE GLULAMS have the same structural grade, 24F-V4. Appearance grade does not affect the beam's load capacity.
- Uniform PLF load values are limited by shear, moment, total load deflection limited to L/240 and live load deflection limited to L/360.
- Live load is equal to 0.8 of total load (residential loading).

- Span is measured center to center of the supports.
- Table values assume that lateral support is provided at each support and continuously along the compression edge of the beam.
- Table values for Minimum Required Bearing Lengths are based on the allowable compression design value perpendicular to grain for the beam and the load value shown. Other design

- considerations, such as a weaker support material, may warrant longer bearing lengths. Table values assume that support is provided across the full width of the beam.
- This table was designed to apply to a broad range of applications. It may be possible to exceed the limitations of this table by analyzing a specific application with the BC CALC® software.

# BOISE GLULAM® Beams Roof Load Tables

## Architectural Appearance Beams 3 1/8" Roof Load Tables – 115% Snow

Span [ft]	24F-V4 Grade – 115% Load Duration In pounds per lineal foot (PLF)									
	Span Type	6"	7.5"	9"	10.5"	12"	13.5"	15"	16.5"	18"
6	Simple	954	1492	2149	2927	3800	4561	5431	6434	7605
	Multiple	734	1149	1655	2254	2761	3255	3798	4398	5065
	Min. Bearing	1.5 / 3	2.2 / 4.3	3.2 / 6.1	4.3 / 8.4	5.6 / 10.2	6.8 / 12.1	8 / 14.1	9.5 / 16.3	11.3 / 18.8
8	Simple	535	837	1206	1643	2147	2719	3358	3978	4558
	Multiple	411	644	928	1265	1653	2093	2528	2877	3252
	Min. Bearing	1.5 / 3	1.7 / 3.2	2.4 / 4.6	3.3 / 6.3	4.2 / 8.2	5.4 / 10.4	6.6 / 12.5	7.9 / 14.2	9 / 16.1
10	Simple	295	533	769	1049	1371	1736	2145	2597	3091
	Multiple	261	410	592	806	1055	1336	1651	1999	2380
	Min. Bearing	1.5 / 3	1.5 / 3	1.9 / 3.7	2.6 / 5	3.4 / 6.5	4.3 / 8.3	5.3 / 10.2	6.4 / 12.4	7.6 / 14.7
12	Simple	169	333	532	726	949	1203	1486	1799	2143
	Multiple	180	283	409	558	730	925	1143	1384	1648
	Min. Bearing	1.5 / 3	1.5 / 3	1.6 / 3.1	2.2 / 4.2	2.8 / 5.5	3.6 / 6.9	4.4 / 8.5	5.4 / 10.3	6.4 / 12.3
14	Simple	105	208	362	531	695	881	1089	1319	1571
	Multiple	131	206	298	408	534	677	837	1014	1207
	Min. Bearing	1.5 / 3	1.5 / 3	1.5 / 3	1.9 / 3.6	2.4 / 4.7	3.1 / 5.9	3.8 / 7.3	4.6 / 8.8	5.5 / 10.5
16	Simple	69	137	240	385	530	672	831	1007	1199
	Multiple	92	157	227	310	406	516	638	773	921
	Min. Bearing	1.5 / 3	1.5 / 3	1.5 / 3	1.5 / 3.1	2.1 / 4.1	2.7 / 5.2	3.3 / 6.4	4 / 7.7	4.8 / 9.2
18	Simple	47	95	167	268	402	529	654	793	945
	Multiple	63	123	178	243	319	405	502	608	725
	Min. Bearing	1.5 / 3	1.5 / 3	1.5 / 3	1.5 / 3	1.8 / 3.6	2.4 / 4.6	2.9 / 5.7	3.6 / 6.9	4.2 / 8.2
20	Simple	-	68	120	193	291	417	528	640	763
	Multiple	-	91	143	196	257	326	404	490	585
	Min. Bearing	-	1.5 / 3	1.5 / 3	1.5 / 3	1.5 / 3.3	2.1 / 4.1	2.7 / 5.1	3.2 / 6.2	3.8 / 7.4
22	Simple	-	49	88	143	216	311	429	527	628
	Multiple	-	67	117	160	211	268	332	403	481
	Min. Bearing	-	1.5 / 3	1.5 / 3	1.5 / 3	1.5 / 3	1.7 / 3.8	2.4 / 4.6	2.9 / 5.6	3.5 / 6.7
24	Simple	-	-	66	108	164	237	328	439	523
	Multiple	-	-	89	133	176	223	277	337	400
	Min. Bearing	-	-	1.5 / 3	1.5 / 3	1.5 / 3	1.5 / 3.5	2 / 4.3	2.7 / 5.2	3.2 / 6.1
26	Simple	-	-	51	84	127	184	255	342	440
	Multiple	-	-	69	112	148	189	234	284	336
	Min. Bearing	-	-	1.5 / 3	1.5 / 3	1.5 / 3	1.5 / 3.2	1.7 / 3.9	2.3 / 4.7	2.9 / 5.6
28	Simple	-	-	-	65	100	145	202	272	355
	Multiple	-	-	-	88	127	161	200	241	286
	Min. Bearing	-	-	-	1.5 / 3	1.5 / 3	1.5 / 3	1.5 / 3.6	2 / 4.4	2.5 / 5.2
30	Simple	-	-	-	52	80	116	162	219	286
	Multiple	-	-	-	70	108	139	172	207	245
	Min. Bearing	-	-	-	1.5 / 3	1.5 / 3	1.5 / 3	1.5 / 3.4	1.7 / 4.1	2.2 / 4.8
32	Simple	-	-	-	-	64	94	132	178	234
	Multiple	-	-	-	-	87	121	149	179	212
	Min. Bearing	-	-	-	-	1.5 / 3	1.5 / 3	1.5 / 3.1	1.5 / 3.8	1.9 / 4.5
34	Simple	-	-	-	-	52	77	108	146	192
	Multiple	-	-	-	-	71	104	129	156	185
	Min. Bearing	-	-	-	-	1.5 / 3	1.5 / 3	1.5 / 3	1.5 / 3.5	1.7 / 4.2
36	Simple	-	-	-	-	-	63	89	121	160
	Multiple	-	-	-	-	-	86	113	137	163
	Min. Bearing	-	-	-	-	-	1.5 / 3	1.5 / 3	1.5 / 3.3	1.5 / 3.9
38	Simple	-	-	-	-	-	52	74	101	134
	Multiple	-	-	-	-	-	72	100	121	144
	Min. Bearing	-	-	-	-	-	1.5 / 3	1.5 / 3	1.5 / 3.1	1.5 / 3.7
40	Simple	-	-	-	-	-	-	62	85	113
	Multiple	-	-	-	-	-	-	85	107	128
	Min. Bearing	-	-	-	-	-	-	1.5 / 3	1.5 / 3	1.5 / 3.5

- Both Architectural and Industrial appearance grade BOISE GLULAMS have the same structural grade, 24F-V4. Appearance grade does not affect the beam's load capacity.
- Uniform PLF load values are limited by shear, moment, total load deflection limited to L/180 and live load deflection limited to L/240.
- Live load equal to 0.75 of total load, for greater live/total applications (e.g. 50 psf snow or higher), analyze specific application with BC CALC® software.
- Span is measured center to center of the supports.
- Table values assume that lateral support is provided at each support and continuously along the compression edge of the beam.
- Table values for Minimum Required Bearing Lengths are based on the allowable compression design value perpendicular to grain for the beam and the load value shown. Other design considerations, such as a weaker support material, may warrant longer bearing lengths. Table values assume that support is provided across the full width of the beam.
- This table was designed to apply to a broad range of applications. It may be possible to exceed the limitations of this table by analyzing a specific application with the BC CALC® software.

# BOISE GLULAM® Beams Roof Load Tables

## Architectural Appearance Beams 5 1/8" Roof Load Tables – 115% Snow

Span [ft]	24F-V4 Grade – 115% Load Duration In pounds per lineal foot (PLF)													
	Span Type	6"	7.5"	9"	10.5"	12"	13.5"	15"	16.5"	18"	19.5"	21"	22.5"	24"
6	Simple	1564	2446	3525	4800	6232	7480	8906	10552	12472				
	Multiple	1204	1884	2715	3697	4529	5338	6229	7213	8307				
	Min. Bearing	1.5 / 3	2.2 / 4.3	3.2 / 6.1	4.3 / 8.4	5.6 / 10.2	6.8 / 12.1	8 / 14.1	9.5 / 16.3	11.3 / 18.8				
8	Simple	877	1372	1978	2694	3521	4459	5507	6524	7474	8525	9692		
	Multiple	674	1055	1522	2074	2711	3433	4146	4719	5332	5992	6702		
	Min. Bearing	1.5 / 3	1.7 / 3.2	2.4 / 4.6	3.3 / 6.3	4.2 / 8.2	5.4 / 10.4	6.6 / 12.5	7.9 / 14.2	9 / 16.1	10.3 / 18.1	11.7 / 20.2		
10	Simple	485	875	1262	1720	2248	2848	3518	4258	5070	5952	6702	7469	
	Multiple	429	672	970	1323	1730	2191	2707	3278	3903	4366	4833	5327	
	Min. Bearing	1.5 / 3	1.5 / 3	1.9 / 3.7	2.6 / 5	3.4 / 6.5	4.3 / 8.3	5.3 / 10.2	6.4 / 12.4	7.6 / 14.7	9 / 16.5	10.1 / 18.2	11.3 / 20.1	
12	Simple	277	547	873	1190	1557	1972	2437	2951	3514	4126	4787	5459	6173
	Multiple	295	464	670	914	1197	1516	1874	2270	2703	3175	3684	4137	4514
	Min. Bearing	1.5 / 3	1.5 / 3	1.6 / 3.1	2.2 / 4.2	2.8 / 5.5	3.6 / 6.9	4.4 / 8.5	5.4 / 10.3	6.4 / 12.3	7.5 / 14.4	8.7 / 16.7	9.9 / 18.8	11.2 / 20.5
14	Simple	172	341	594	871	1140	1445	1786	2163	2576	3001	3456	3942	4458
	Multiple	215	338	489	668	875	1110	1372	1662	1980	2307	2658	3032	3429
	Min. Bearing	1.5 / 3	1.5 / 3	1.5 / 3	1.9 / 3.6	2.4 / 4.7	3.1 / 5.9	3.8 / 7.3	4.6 / 8.8	5.5 / 10.5	6.4 / 12.2	7.3 / 14.1	8.3 / 16.1	9.4 / 18.2
16	Simple	113	225	394	631	869	1102	1363	1643	1940	2261	2605	2971	3360
	Multiple	151	257	372	509	667	846	1046	1262	1491	1737	2002	2284	2584
	Min. Bearing	1.5 / 3	1.5 / 3	1.5 / 3	1.5 / 3.1	2.1 / 4.1	2.7 / 5.2	3.3 / 6.4	4 / 7.7	4.7 / 9.1	5.5 / 10.6	6.3 / 12.2	7.2 / 13.9	8.1 / 15.7
18	Simple	77	155	274	439	660	867	1065	1279	1510	1760	2028	2314	2618
	Multiple	103	201	292	399	523	665	817	981	1159	1351	1557	1777	2011
	Min. Bearing	1.5 / 3	1.5 / 3	1.5 / 3	1.5 / 3	1.8 / 3.6	2.4 / 4.6	2.9 / 5.6	3.5 / 6.8	4.1 / 8	4.8 / 9.3	5.5 / 10.7	6.3 / 12.2	7.2 / 13.8
20	Simple	54	111	196	317	477	684	850	1021	1206	1406	1620	1849	2092
	Multiple	73	149	234	321	421	531	651	782	925	1078	1243	1419	1606
	Min. Bearing	1.5 / 3	1.5 / 3	1.5 / 3	1.5 / 3	1.5 / 3.3	2.1 / 4.1	2.6 / 5	3.1 / 6	3.7 / 7.1	4.3 / 8.3	4.9 / 9.5	5.6 / 10.9	6.4 / 12.3
22	Simple	-	81	145	235	355	509	693	832	983	1146	1322	1509	1707
	Multiple	-	109	192	263	344	432	530	636	753	878	1013	1156	1309
	Min. Bearing	-	1.5 / 3	1.5 / 3	1.5 / 3	1.5 / 3	1.7 / 3.7	2.3 / 4.5	2.8 / 5.4	3.3 / 6.4	3.9 / 7.5	4.5 / 8.6	5.1 / 9.8	5.7 / 11.1
24	Simple	-	60	109	178	270	389	537	689	815	951	1097	1252	1417
	Multiple	-	82	147	219	284	357	438	527	623	727	839	959	1085
	Min. Bearing	-	1.5 / 3	1.5 / 3	1.5 / 3	1.5 / 3	1.5 / 3.4	2 / 4.1	2.6 / 4.9	3 / 5.8	3.5 / 6.8	4 / 7.8	4.6 / 8.9	5.2 / 10
26	Simple	-	45	83	137	209	302	419	562	686	800	923	1054	1193
	Multiple	-	63	113	183	238	299	367	442	523	611	705	806	913
	Min. Bearing	-	1.5 / 3	1.5 / 3	1.5 / 3	1.5 / 3	1.5 / 3.1	1.7 / 3.8	2.3 / 4.5	2.8 / 5.3	3.2 / 6.2	3.7 / 7.1	4.2 / 8.1	4.8 / 9.2
28	Simple	-	-	64	107	164	238	332	446	583	681	786	898	1017
	Multiple	-	-	88	145	201	254	312	375	445	520	600	686	777
	Min. Bearing	-	-	1.5 / 3	1.5 / 3	1.5 / 3	1.5 / 3	1.5 / 3.5	2 / 4.2	2.5 / 4.9	3 / 5.7	3.4 / 6.6	3.9 / 7.5	4.4 / 8.5
30	Simple	-	-	50	85	131	191	266	358	470	586	677	773	876
	Multiple	-	-	70	115	172	217	267	322	382	446	515	589	668
	Min. Bearing	-	-	1.5 / 3	1.5 / 3	1.5 / 3	1.5 / 3	1.5 / 3.2	1.7 / 3.9	2.2 / 4.5	2.7 / 5.3	3.2 / 6.1	3.6 / 7	4.1 / 7.9
32	Simple	-	-	-	67	105	154	216	292	383	491	587	672	761
	Multiple	-	-	-	93	143	187	231	279	330	387	447	511	580
	Min. Bearing	-	-	-	1.5 / 3	1.5 / 3	1.5 / 3	1.5 / 3	1.5 / 3.6	1.9 / 4.2	2.5 / 4.9	2.9 / 5.7	3.4 / 6.5	3.8 / 7.3
34	Simple	-	-	-	54	85	126	177	240	316	405	511	588	666
	Multiple	-	-	-	75	117	163	201	243	288	337	390	447	507
	Min. Bearing	-	-	-	1.5 / 3	1.5 / 3	1.5 / 3	1.5 / 3	1.5 / 3.4	1.7 / 4	2.2 / 4.6	2.7 / 5.3	3.1 / 6.1	3.6 / 6.8
36	Simple	-	-	-	-	69	103	146	199	262	338	426	518	588
	Multiple	-	-	-	-	96	141	176	213	253	297	343	393	446
	Min. Bearing	-	-	-	-	1.5 / 3	1.5 / 3	1.5 / 3	1.5 / 3.2	1.5 / 3.7	2 / 4.3	2.4 / 5	3 / 5.7	3.3 / 6.4
38	Simple	-	-	-	-	57	85	121	166	220	284	358	445	521
	Multiple	-	-	-	-	79	118	155	188	224	262	304	348	395
	Min. Bearing	-	-	-	-	1.5 / 3	1.5 / 3	1.5 / 3	1.5 / 3	1.5 / 3.5	1.8 / 4.1	2.2 / 4.7	2.7 / 5.4	3.1 / 6.1
40	Simple	-	-	-	-	47	71	101	139	185	240	303	377	462
	Multiple	-	-	-	-	66	98	138	167	198	233	270	309	352
	Min. Bearing	-	-	-	-	1.5 / 3	1.5 / 3	1.5 / 3	1.5 / 3	1.5 / 3.3	1.6 / 3.9	2 / 4.4	2.4 / 5.1	3 / 5.7

- Both Architectural and Industrial appearance grade BOISE GLULAMS have the same structural grade, 24F-V4. Appearance grade does not affect the beam's load capacity.
- Uniform PLF load values are limited by shear, moment, total load deflection limited to L/180 and live load deflection limited to L/240.
- Live load equal to 0.75 of total load, for greater live/total applications (e.g. 50 psf snow or higher), analyze specific application with BC CALC® software.
- Span is measured center to center of the supports.
- Table values assume that lateral support is provided at each support and continuously along the compression edge of the beam.
- Table values for Minimum Required Bearing Lengths are based on the allowable compression design value perpendicular to grain for the beam and the load value shown. Other design considerations, such as a weaker support material, may warrant longer bearing lengths. Table values assume that support is provided across the full width of the beam.
- This table was designed to apply to a broad range of applications. It may be possible to exceed the limitations of this table by analyzing a specific application with the BC CALC® software.

# BOISE GLULAM® Beams Roof Load Tables

## Architectural Appearance Beams 6<sup>3</sup>/<sub>4</sub>" Roof Load Tables – 115% Snow

Span [ft]	24F-V4 Grade – 115% Load Duration In pounds per lineal foot (PLF)												
	Span Type	7.5"	9"	10.5"	12"	13.5"	15"	16.5"	18"	19.5"	21"	22.5"	24"
6	Simple	3222	4643	6322	8209	9852	11730	13898	16427				
	Multiple	2481	3575	4869	5964	7031	8204	9500	10941				
	Min. Bearing	2.2 / 4.3	3.2 / 6.1	4.3 / 8.4	5.6 / 10.2	6.8 / 12.1	8 / 14.1	9.5 / 16.3	11.3 / 18.8				
8	Simple	1807	2605	3549	4638	5872	7253	8593	9844	11228	12765		
	Multiple	1390	2005	2731	3570	4522	5461	6215	7023	7892	8827		
	Min. Bearing	1.7 / 3.2	2.4 / 4.6	3.3 / 6.3	4.2 / 8.2	5.4 / 10.4	6.6 / 12.5	7.9 / 14.2	9 / 16.1	10.3 / 18.1	11.7 / 20.2		
10	Simple	1152	1662	2265	2961	3750	4633	5609	6677	7824	8827	9837	
	Multiple	885	1278	1742	2278	2886	3566	4317	5140	5750	6365	7016	
	Min. Bearing	1.5 / 3	1.9 / 3.7	2.6 / 5	3.4 / 6.5	4.3 / 8.3	5.3 / 10.2	6.4 / 12.4	7.6 / 14.7	9 / 16.5	10.1 / 18.2	11.3 / 20.1	
12	Simple	720	1150	1568	2050	2598	3210	3873	4572	5325	6133	6994	7909
	Multiple	611	883	1204	1576	1997	2469	2979	3517	4097	4719	5383	5945
	Min. Bearing	1.5 / 3	1.6 / 3.1	2.2 / 4.2	2.8 / 5.5	3.6 / 6.9	4.4 / 8.5	5.3 / 10.3	6.3 / 12.1	7.3 / 14.1	8.4 / 16.3	9.6 / 18.5	10.9 / 20.5
14	Simple	449	782	1147	1501	1903	2330	2795	3299	3844	4427	5050	5711
	Multiple	446	645	880	1153	1462	1790	2148	2536	2955	3405	3884	4393
	Min. Bearing	1.5 / 3	1.5 / 3	1.9 / 3.6	2.4 / 4.7	3.1 / 5.9	3.8 / 7.2	4.5 / 8.7	5.3 / 10.2	6.2 / 11.9	7.1 / 13.7	8.1 / 15.6	9.2 / 17.7
16	Simple	297	519	831	1144	1434	1754	2105	2485	2896	3336	3806	4305
	Multiple	338	490	670	878	1100	1346	1616	1909	2225	2564	2925	3309
	Min. Bearing	1.5 / 3	1.5 / 3	1.5 / 3.1	2.1 / 4.1	2.7 / 5.1	3.2 / 6.2	3.9 / 7.5	4.6 / 8.8	5.3 / 10.3	6.1 / 11.8	7 / 13.5	7.9 / 15.3
18	Simple	205	360	578	869	1115	1364	1637	1934	2254	2598	2964	3353
	Multiple	265	384	526	681	854	1046	1256	1484	1730	1994	2276	2575
	Min. Bearing	1.5 / 3	1.5 / 3	1.5 / 3	1.8 / 3.6	2.3 / 4.5	2.8 / 5.5	3.4 / 6.6	4 / 7.8	4.7 / 9	5.4 / 10.4	6.2 / 11.9	7 / 13.4
20	Simple	146	259	417	628	889	1089	1307	1544	1801	2075	2368	2679
	Multiple	196	308	418	542	680	833	1001	1184	1381	1592	1817	2056
	Min. Bearing	1.5 / 3	1.5 / 3	1.5 / 3	1.5 / 3.2	2.1 / 4	2.5 / 4.9	3 / 5.9	3.6 / 6.9	4.2 / 8	4.8 / 9.3	5.5 / 10.6	6.2 / 11.9
22	Simple	107	191	309	467	671	887	1065	1259	1468	1692	1932	2186
	Multiple	144	251	339	440	553	678	815	964	1124	1297	1481	1676
	Min. Bearing	1.5 / 3	1.5 / 3	1.5 / 3	1.5 / 3	1.7 / 3.6	2.3 / 4.4	2.7 / 5.3	3.2 / 6.2	3.8 / 7.2	4.3 / 8.3	4.9 / 9.5	5.6 / 10.8
24	Simple	79	143	234	355	512	708	883	1044	1218	1404	1603	1815
	Multiple	108	193	280	363	457	561	674	798	931	1074	1227	1390
	Min. Bearing	1.5 / 3	1.5 / 3	1.5 / 3	1.5 / 3	1.5 / 3.3	2 / 4	2.5 / 4.8	2.9 / 5.7	3.4 / 6.6	3.9 / 7.6	4.5 / 8.6	5.1 / 9.8
26	Simple	60	110	180	275	398	551	740	878	1024	1182	1349	1528
	Multiple	82	149	234	304	383	470	566	670	782	903	1032	1169
	Min. Bearing	1.5 / 3	1.5 / 3	1.5 / 3	1.5 / 3	1.5 / 3	1.7 / 3.7	2.3 / 4.4	2.7 / 5.2	3.1 / 6	3.6 / 6.9	4.1 / 7.9	4.6 / 8.9
28	Simple	45	85	141	216	314	437	587	747	872	1006	1150	1302
	Multiple	64	116	191	257	324	399	480	569	665	768	878	995
	Min. Bearing	1.5 / 3	1.5 / 3	1.5 / 3	1.5 / 3	1.5 / 3	1.5 / 3.4	2 / 4	2.5 / 4.8	2.9 / 5.6	3.3 / 6.4	3.8 / 7.3	4.3 / 8.2
30	Simple	-	66	111	172	251	350	472	618	750	866	990	1121
	Multiple	-	92	152	220	278	342	412	488	571	660	754	855
	Min. Bearing	-	1.5 / 3	1.5 / 3	1.5 / 3	1.5 / 3	1.5 / 3.1	1.7 / 3.8	2.2 / 4.4	2.7 / 5.2	3.1 / 5.9	3.5 / 6.8	4 / 7.6
32	Simple	-	52	89	139	203	284	384	504	647	752	859	974
	Multiple	-	73	122	188	240	295	356	423	494	572	654	742
	Min. Bearing	-	1.5 / 3	1.5 / 3	1.5 / 3	1.5 / 3	1.5 / 3	1.5 / 3.5	1.9 / 4.1	2.5 / 4.8	2.9 / 5.5	3.3 / 6.3	3.7 / 7.1
34	Simple	-	-	71	112	166	233	316	416	534	658	752	853
	Multiple	-	-	99	154	208	257	310	369	432	499	571	648
	Min. Bearing	-	-	1.5 / 3	1.5 / 3	1.5 / 3	1.5 / 3	1.5 / 3.3	1.7 / 3.9	2.2 / 4.5	2.7 / 5.2	3.1 / 5.9	3.5 / 6.7
36	Simple	-	-	57	91	136	192	262	345	445	561	663	752
	Multiple	-	-	81	126	182	225	272	324	379	439	503	571
	Min. Bearing	-	-	1.5 / 3	1.5 / 3	1.5 / 3	1.5 / 3	1.5 / 3.1	1.5 / 3.6	2 / 4.2	2.4 / 4.9	2.9 / 5.5	3.2 / 6.3
38	Simple	-	-	46	75	112	160	219	289	373	472	586	667
	Multiple	-	-	66	105	155	198	240	286	335	388	445	505
	Min. Bearing	-	-	1.5 / 3	1.5 / 3	1.5 / 3	1.5 / 3	1.5 / 3	1.5 / 3.4	1.8 / 4	2.2 / 4.6	2.7 / 5.2	3.1 / 5.9
40	Simple	-	-	-	61	93	134	183	244	316	400	497	595
	Multiple	-	-	-	87	130	176	213	253	298	345	396	449
	Min. Bearing	-	-	-	1.5 / 3	1.5 / 3	1.5 / 3	1.5 / 3	1.5 / 3.2	1.6 / 3.8	2 / 4.3	2.4 / 4.9	2.9 / 5.6

- Both Architectural and Industrial appearance grade BOISE GLULAMS have the same structural grade, 24F-V4. Appearance grade does not affect the beam's load capacity.
- Uniform PLF load values are limited by shear, moment, total load deflection limited to L/180 and live load deflection limited to L/240.
- Live load equal to 0.75 of total load, for greater live/total applications (e.g. 50 psf snow or higher), analyze specific application with BC CALC® software.
- Span is measured center to center of the supports.
- Table values assume that lateral support is provided at each support and continuously along the compression edge of the beam.
- Table values for Minimum Required Bearing Lengths are based on the allowable compression design value perpendicular to grain for the beam and the load value shown. Other design considerations, such as a weaker support material, may warrant longer bearing lengths. Table values assume that support is provided across the full width of the beam.
- This table was designed to apply to a broad range of applications. It may be possible to exceed the limitations of this table by analyzing a specific application with the BC Calc software.

# BOISE GLULAM® Beams Roof Load Tables

## Architectural Appearance Beams 8 3/4" Roof Load Tables – 115% Snow

### 24F-V4 Grade – 115% Load Duration In pounds per lineal foot (PLF)

Span [ft]	Span Type	9"	10.5"	12"	13.5"	15"	16.5"	18"	19.5"	21"	22.5"	24"
		6	Simple	6018	8195	10641	12771	15206	18015	21294	25170	29821
	Multiple	4635	6312	7732	9114	10634	12315	14183	16272	18621	21285	24329
	Min. Bearing	3.2 / 6.1	4.3 / 8.4	5.6 / 10.2	6.8 / 12.1	8 / 14.1	9.5 / 16.3	11.3 / 18.8	13.3 / 21.5	15.8 / 24.6	18.8 / 28.1	22.5 / 32.1
8	Simple	3377	4600	6012	7612	9402	11139	12761	14554	16547	18775	21281
	Multiple	2599	3541	4628	5861	7079	8057	9104	10230	11442	12752	14171
	Min. Bearing	2.4 / 4.6	3.3 / 6.3	4.2 / 8.2	5.4 / 10.4	6.6 / 12.5	7.9 / 14.2	9 / 16.1	10.3 / 18.1	11.7 / 20.2	13.2 / 22.5	15 / 25
10	Simple	2154	2936	3838	4862	5996	7189	8485	9882	11379	12752	14171
	Multiple	1656	2258	2953	3741	4615	5534	6532	7454	8251	9095	9988
	Min. Bearing	1.9 / 3.7	2.6 / 5	3.4 / 6.5	4.3 / 8.3	5.3 / 10.2	6.4 / 12.2	7.5 / 14.4	8.7 / 16.5	10 / 18.2	11.3 / 20.1	12.5 / 22.1
12	Simple	1490	2032	2658	3336	4078	4891	5774	6725	7745	8833	9988
	Multiple	1144	1561	2043	2565	3136	3762	4442	5174	5960	6798	7688
	Min. Bearing	1.6 / 3.1	2.2 / 4.2	2.8 / 5.5	3.5 / 6.8	4.3 / 8.4	5.2 / 10	6.1 / 11.8	7.1 / 13.8	8.2 / 15.8	9.4 / 18.1	10.6 / 20.4
14	Simple	1014	1487	1921	2405	2942	3529	4166	4854	5591	6377	7212
	Multiple	836	1141	1475	1848	2260	2712	3203	3732	4299	4905	5548
	Min. Bearing	1.5 / 3	1.9 / 3.6	2.4 / 4.6	3 / 5.8	3.7 / 7.1	4.4 / 8.5	5.2 / 10	6 / 11.6	6.9 / 13.4	7.9 / 15.2	8.9 / 17.2
16	Simple	673	1077	1445	1810	2215	2657	3138	3657	4213	4806	5436
	Multiple	635	857	1108	1389	1700	2040	2410	2809	3237	3694	4178
	Min. Bearing	1.5 / 3	1.5 / 3.1	2.1 / 4	2.6 / 5	3.2 / 6.1	3.8 / 7.3	4.5 / 8.6	5.2 / 10	6 / 11.5	6.8 / 13.2	7.7 / 14.9
18	Simple	467	750	1123	1407	1722	2067	2442	2846	3280	3742	4234
	Multiple	493	664	859	1078	1320	1586	1874	2185	2518	2874	3252
	Min. Bearing	1.5 / 3	1.5 / 3	1.8 / 3.5	2.3 / 4.4	2.8 / 5.3	3.3 / 6.4	3.9 / 7.6	4.6 / 8.8	5.3 / 10.1	6 / 11.6	6.8 / 13.1
20	Simple	335	540	814	1122	1374	1650	1950	2273	2620	2990	3383
	Multiple	391	528	684	858	1052	1264	1494	1743	2009	2294	2596
	Min. Bearing	1.5 / 3	1.5 / 3	1.5 / 3.1	2 / 3.9	2.5 / 4.8	3 / 5.7	3.5 / 6.7	4.1 / 7.8	4.7 / 9	5.3 / 10.3	6 / 11.6
22	Simple	247	400	606	870	1119	1344	1589	1853	2137	2439	2760
	Multiple	317	428	555	698	855	1028	1216	1419	1637	1869	2116
	Min. Bearing	1.5 / 3	1.5 / 3	1.5 / 3	1.7 / 3.5	2.2 / 4.3	2.7 / 5.1	3.1 / 6.1	3.7 / 7.1	4.2 / 8.1	4.8 / 9.3	5.4 / 10.5
24	Simple	186	303	461	663	918	1114	1317	1537	1772	2024	2291
	Multiple	251	353	458	576	707	851	1007	1175	1356	1549	1754
	Min. Bearing	1.5 / 3	1.5 / 3	1.5 / 3	1.5 / 3.2	2 / 3.9	2.4 / 4.7	2.9 / 5.5	3.3 / 6.4	3.8 / 7.4	4.4 / 8.4	4.9 / 9.5
26	Simple	142	234	357	516	715	936	1108	1293	1491	1703	1928
	Multiple	193	295	383	483	593	714	845	987	1139	1302	1475
	Min. Bearing	1.5 / 3	1.5 / 3	1.5 / 3	1.5 / 3	1.7 / 3.6	2.2 / 4.3	2.6 / 5	3 / 5.9	3.5 / 6.8	4 / 7.7	4.5 / 8.7
28	Simple	110	183	281	407	566	761	942	1100	1270	1451	1643
	Multiple	151	247	324	409	503	606	718	839	969	1107	1255
	Min. Bearing	1.5 / 3	1.5 / 3	1.5 / 3	1.5 / 3	1.5 / 3.3	2 / 3.9	2.4 / 4.7	2.8 / 5.4	3.2 / 6.2	3.7 / 7.1	4.2 / 8
30	Simple	86	144	223	326	454	612	802	946	1093	1249	1415
	Multiple	119	197	277	350	431	519	616	720	832	952	1079
	Min. Bearing	1.5 / 3	1.5 / 3	1.5 / 3	1.5 / 3	1.5 / 3	1.7 / 3.7	2.2 / 4.3	2.6 / 5	3 / 5.8	3.4 / 6.6	3.9 / 7.4
32	Simple	67	115	180	263	369	498	654	821	948	1084	1229
	Multiple	95	158	239	302	372	449	533	623	721	825	936
	Min. Bearing	1.5 / 3	1.5 / 3	1.5 / 3	1.5 / 3	1.5 / 3	1.5 / 3.4	1.9 / 4	2.4 / 4.7	2.8 / 5.4	3.2 / 6.1	3.6 / 6.9
34	Simple	53	92	145	215	302	409	539	692	830	949	1076
	Multiple	76	128	199	262	324	391	465	544	629	721	818
	Min. Bearing	1.5 / 3	1.5 / 3	1.5 / 3	1.5 / 3	1.5 / 3	1.5 / 3.2	1.7 / 3.8	2.2 / 4.4	2.6 / 5	3 / 5.7	3.4 / 6.5
36	Simple	42	74	119	176	249	339	448	577	727	836	948
	Multiple	61	105	164	229	284	343	408	478	553	634	719
	Min. Bearing	1.5 / 3	1.5 / 3	1.5 / 3	1.5 / 3	1.5 / 3	1.5 / 3	1.5 / 3.5	2 / 4.1	2.4 / 4.7	2.8 / 5.4	3.2 / 6.1
38	Simple	-	60	97	146	207	283	375	484	612	741	841
	Multiple	-	86	136	201	250	302	360	422	489	560	637
	Min. Bearing	-	1.5 / 3	1.5 / 3	1.5 / 3	1.5 / 3	1.5 / 3	1.5 / 3.3	1.8 / 3.9	2.2 / 4.5	2.6 / 5.1	3 / 5.7
40	Simple	-	48	79	121	173	238	316	409	518	644	750
	Multiple	-	70	113	168	221	268	319	375	434	498	566
	Min. Bearing	-	1.5 / 3	1.5 / 3	1.5 / 3	1.5 / 3	1.5 / 3	1.5 / 3.1	1.6 / 3.7	2 / 4.2	2.4 / 4.8	2.8 / 5.4

- Both Architectural and Industrial appearance grade BOISE GLULAMS have the same structural grade, 24F-V4. Appearance grade does not affect the beam's load capacity.
- Uniform PLF load values are limited by shear, moment, total load deflection limited to L/180 and live load deflection limited to L/240.
- Live load equal to 0.75 of total load, for greater live/total applications (e.g. 50 psf snow or higher), analyze specific application with BC CALC® software.
- Span is measured center to center of the supports.

- Table values assume that lateral support is provided at each support and continuously along the compression edge of the beam.
- Table values for Minimum Required Bearing Lengths are based on the allowable compression design value perpendicular to grain for the beam and the load value shown. Other design considerations, such as a weaker support material, may warrant longer bearing lengths. Table values assume that support is provided across the full width of the beam.
- This table was designed to apply to a broad range of applications. It may be possible to exceed the limitations of this table by analyzing a specific application with the BC CALC® software.

# BOISE GLULAM® Beams Roof Load Tables

## Industrial Appearance Headers 3 1/2" and 5 1/2" Roof Load Tables – 115% Snow

		24F-V4 Grade – 115% Load Duration In pounds per lineal foot (PLF)												
Span [ft]	Span Type	3 1/2"								5 1/2"				
		4.5"	6"	7.5"	9"	10.5"	12"	13.5"	15"	9"	10.5"	12"	13.5"	15"
6	Simple	600	1068	1671	2407	3278	4256	5108	6082	3783	5151	6688	8027	9558
	Multiple	462	822	1286	1854	2525	3093	3646	4254	2913	3968	4860	5729	6684
	Min. Bearing	1.5 / 3	1.5 / 3	2.2 / 4.3	3.2 / 6.1	4.3 / 8.4	5.6 / 10.2	6.8 / 12.1	8 / 14.1	3.2 / 6.1	4.3 / 8.4	5.6 / 10.2	6.8 / 12.1	8 / 14.1
8	Simple	273	599	937	1351	1840	2405	3045	3761	2123	2892	3779	4785	5910
	Multiple	258	460	721	1039	1416	1851	2345	2832	1633	2226	2909	3684	4450
	Min. Bearing	1.5 / 3	1.5 / 3	1.7 / 3.2	2.4 / 4.6	3.3 / 6.3	4.2 / 8.2	5.4 / 10.4	6.6 / 12.5	2.4 / 4.6	3.3 / 6.3	4.2 / 8.2	5.4 / 10.4	6.6 / 12.5
10	Simple	138	331	597	862	1174	1535	1945	2402	1354	1846	2413	3056	3775
	Multiple	164	293	459	663	903	1181	1496	1849	1041	1419	1856	2351	2905
	Min. Bearing	1.5 / 3	1.5 / 3	1.5 / 3	1.9 / 3.7	2.6 / 5	3.4 / 6.5	4.3 / 8.3	5.3 / 10.2	1.9 / 3.7	2.6 / 5	3.4 / 6.5	4.3 / 8.3	5.3 / 10.2
12	Simple	78	189	373	596	813	1063	1347	1664	937	1277	1671	2117	2615
	Multiple	104	202	317	458	625	817	1036	1280	719	981	1284	1627	2011
	Min. Bearing	1.5 / 3	1.5 / 3	1.5 / 3	1.6 / 3.1	2.2 / 4.2	2.8 / 5.5	3.6 / 6.9	4.4 / 8.5	1.6 / 3.1	2.2 / 4.2	2.8 / 5.5	3.6 / 6.9	4.4 / 8.5
14	Simple	48	117	233	406	595	778	987	1219	637	935	1223	1550	1916
	Multiple	64	147	231	334	456	598	758	937	525	717	939	1191	1472
	Min. Bearing	1.5 / 3	1.5 / 3	1.5 / 3	1.5 / 3	1.9 / 3.6	2.4 / 4.7	3.1 / 5.9	3.8 / 7.3	1.5 / 3	1.9 / 3.6	2.4 / 4.7	3.1 / 5.9	3.8 / 7.3
16	Simple	-	77	154	269	431	594	753	931	423	677	933	1183	1459
	Multiple	-	103	175	254	347	455	578	714	399	546	715	908	1120
	Min. Bearing	-	1.5 / 3	1.5 / 3	1.5 / 3	1.5 / 3.1	2.1 / 4.1	2.7 / 5.2	3.3 / 6.4	1.5 / 3	1.5 / 3.1	2.1 / 4.1	2.7 / 5.2	3.3 / 6.4
18	Simple	-	53	106	187	300	451	592	733	294	471	708	927	1135
	Multiple	-	71	137	199	273	358	454	562	313	428	562	711	870
	Min. Bearing	-	1.5 / 3	1.5 / 3	1.5 / 3	1.5 / 3	1.8 / 3.6	2.4 / 4.6	2.9 / 5.7	1.5 / 3	1.5 / 3	1.8 / 3.6	2.4 / 4.6	2.9 / 5.6
20	Simple	-	-	76	134	216	326	467	591	211	340	512	734	906
	Multiple	-	-	102	160	219	288	365	453	251	344	451	566	694
	Min. Bearing	-	-	1.5 / 3	1.5 / 3	1.5 / 3	1.5 / 3.3	2.1 / 4.1	2.7 / 5.1	1.5 / 3	1.5 / 3	1.5 / 3.3	2.1 / 4.1	2.6 / 5
22	Simple	-	-	55	99	160	242	348	480	155	252	381	547	738
	Multiple	-	-	75	131	180	236	300	372	206	282	366	460	564
	Min. Bearing	-	-	1.5 / 3	1.5 / 3	1.5 / 3	1.5 / 3	1.7 / 3.8	2.4 / 4.6	1.5 / 3	1.5 / 3	1.5 / 3	1.7 / 3.7	2.3 / 4.5
24	Simple	-	-	41	74	121	184	265	367	117	191	290	417	577
	Multiple	-	-	56	100	149	197	250	310	158	233	302	380	467
	Min. Bearing	-	-	1.5 / 3	1.5 / 3	1.5 / 3	1.5 / 3	1.5 / 3.5	2 / 4.3	1.5 / 3	1.5 / 3	1.5 / 3	1.5 / 3.3	2 / 4.1
26	Simple	-	-	-	57	94	143	206	286	89	147	224	324	449
	Multiple	-	-	-	77	126	166	212	261	121	195	253	319	391
	Min. Bearing	-	-	-	1.5 / 3	1.5 / 3	1.5 / 3	1.5 / 3.2	1.7 / 3.9	1.5 / 3	1.5 / 3	1.5 / 3	1.5 / 3.1	1.7 / 3.7
28	Simple	-	-	-	44	73	112	163	226	69	115	176	256	356
	Multiple	-	-	-	60	99	142	180	222	95	156	214	270	332
	Min. Bearing	-	-	-	1.5 / 3	1.5 / 3	1.5 / 3	1.5 / 3	1.5 / 3.6	1.5 / 3	1.5 / 3	1.5 / 3	1.5 / 3	1.5 / 3.4
30	Simple	-	-	-	-	58	89	130	182	54	91	140	205	286
	Multiple	-	-	-	-	79	121	155	190	75	124	183	231	285
	Min. Bearing	-	-	-	-	1.5 / 3	1.5 / 3	1.5 / 3	1.5 / 3.3	1.5 / 3	1.5 / 3	1.5 / 3	1.5 / 3	1.5 / 3.2
32	Simple	-	-	-	-	46	72	105	147	42	72	113	165	232
	Multiple	-	-	-	-	63	98	133	164	59	100	154	200	246
	Min. Bearing	-	-	-	-	1.5 / 3	1.5 / 3	1.5 / 3	1.5 / 3.1	1.5 / 3	1.5 / 3	1.5 / 3	1.5 / 3	1.5 / 3
34	Simple	-	-	-	-	-	58	86	121	-	58	91	135	190
	Multiple	-	-	-	-	-	80	116	143	-	81	125	174	214
	Min. Bearing	-	-	-	-	-	1.5 / 3	1.5 / 3	1.5 / 3	-	1.5 / 3	1.5 / 3	1.5 / 3	1.5 / 3
36	Simple	-	-	-	-	-	47	71	100	-	47	74	111	157
	Multiple	-	-	-	-	-	66	96	126	-	66	103	151	188
	Min. Bearing	-	-	-	-	-	1.5 / 3	1.5 / 3	1.5 / 3	-	1.5 / 3	1.5 / 3	1.5 / 3	1.5 / 3
38	Simple	-	-	-	-	-	-	58	83	-	-	61	92	130
	Multiple	-	-	-	-	-	-	80	111	-	-	85	126	165
	Min. Bearing	-	-	-	-	-	-	1.5 / 3	1.5 / 3	-	-	1.5 / 3	1.5 / 3	1.5 / 3
40	Simple	-	-	-	-	-	-	48	69	-	-	50	76	109
	Multiple	-	-	-	-	-	-	67	95	-	-	71	106	146
	Min. Bearing	-	-	-	-	-	-	1.5 / 3	1.5 / 3	-	-	1.5 / 3	1.5 / 3	1.5 / 3

- Both Architectural and Industrial appearance grade BOISE GLULAMS have the same structural grade, 24F-V4. Appearance grade does not affect the beam's load capacity.
- Uniform PLF load values are limited by shear, moment, total load deflection limited to L/180 and live load deflection limited to L/240.
- Live load equal to 0.75 of total load, for greater live/total applications (e.g. 50 psf snow or higher), analyze specific application with BC CALC® software.
- Span is measured center to center of the supports.

- Table values assume that lateral support is provided at each support and continuously along the compression edge of the beam.
- Table values for Minimum Required Bearing Lengths are based on the allowable compression design value perpendicular to grain for the beam and the load value shown. Other design considerations, such as a weaker support material, may warrant longer bearing lengths. Table values assume that support is provided across the full width of the beam.
- This table was designed to apply to a broad range of applications. It may be possible to exceed the limitations of this table by analyzing a specific application with the BC CALC® software.

# BOISE GLULAM® Beams Roof Load Tables

## Architectural Appearance Beams 3 1/8" Roof Load Tables – 125% Non-Snow

### 24F-V4 Grade – 125% Load Duration In pounds per lineal foot (PLF)

Span [ft]	Span Type	24F-V4 Grade – 125% Load Duration In pounds per lineal foot (PLF)								
		6"	7.5"	9"	10.5"	12"	13.5"	15"	16.5"	18"
6	Simple	1037	1622	2337	3182	4132	4958	5904	6995	
	Multiple	798	1249	1800	2451	3002	3539	4129	4782	
	Min. Bearing	1.5 / 3	2.4 / 4.6	3.5 / 6.7	4.7 / 9.1	6.1 / 11.1	7.3 / 13.1	8.7 / 15.3	10.3 / 17.7	
8	Simple	581	910	1312	1786	2335	2956	3651	4325	4955
	Multiple	447	700	1009	1375	1798	2276	2749	3129	3535
	Min. Bearing	1.5 / 3	1.8 / 3.5	2.6 / 5	3.5 / 6.8	4.6 / 8.9	5.8 / 11.3	7.2 / 13.6	8.5 / 15.5	9.8 / 17.5
10	Simple	295	580	837	1140	1491	1888	2332	2823	3361
	Multiple	285	446	644	877	1147	1453	1795	2174	2588
	Min. Bearing	1.5 / 3	1.5 / 3	2.1 / 4	2.8 / 5.4	3.7 / 7.1	4.7 / 9	5.8 / 11.1	7 / 13.5	8.3 / 16
12	Simple	169	333	579	790	1033	1308	1616	1957	2330
	Multiple	196	308	445	607	794	1006	1243	1506	1793
	Min. Bearing	1.5 / 3	1.5 / 3	1.7 / 3.3	2.4 / 4.5	3.1 / 5.9	3.9 / 7.5	4.8 / 9.3	5.8 / 11.2	6.9 / 13.3
14	Simple	105	208	362	578	756	958	1184	1434	1708
	Multiple	139	225	325	444	581	736	910	1103	1314
	Min. Bearing	1.5 / 3	1.5 / 3	1.5 / 3	2 / 3.9	2.6 / 5.1	3.3 / 6.4	4.1 / 7.9	5 / 9.6	5.9 / 11.4
16	Simple	69	137	240	385	577	731	904	1095	1305
	Multiple	92	171	247	338	443	561	694	841	1003
	Min. Bearing	1.5 / 3	1.5 / 3	1.5 / 3	1.5 / 3.4	2.3 / 4.4	2.9 / 5.6	3.6 / 6.9	4.4 / 8.4	5.2 / 10
18	Simple	47	95	167	268	402	576	712	863	1028
	Multiple	63	126	194	265	348	441	546	662	789
	Min. Bearing	1.5 / 3	1.5 / 3	1.5 / 3	1.5 / 3	1.8 / 4	2.6 / 5	3.2 / 6.2	3.9 / 7.5	4.6 / 8.9
20	Simple	-	68	120	193	291	417	575	696	830
	Multiple	-	91	156	213	280	356	440	534	637
	Min. Bearing	-	1.5 / 3	1.5 / 3	1.5 / 3	1.5 / 3.6	2.1 / 4.5	2.9 / 5.6	3.5 / 6.7	4.2 / 8
22	Simple	-	49	88	143	216	311	429	573	684
	Multiple	-	67	118	175	230	292	362	439	524
	Min. Bearing	-	1.5 / 3	1.5 / 3	1.5 / 3	1.5 / 3.2	1.7 / 4.1	2.4 / 5.1	3.2 / 6.1	3.8 / 7.3
24	Simple	-	-	66	108	164	237	328	439	570
	Multiple	-	-	89	145	192	244	302	367	436
	Min. Bearing	-	-	1.5 / 3	1.5 / 3	1.5 / 3	1.5 / 3.8	2 / 4.6	2.7 / 5.6	3.4 / 6.6
26	Simple	-	-	51	84	127	184	255	342	447
	Multiple	-	-	69	112	162	206	256	310	366
	Min. Bearing	-	-	1.5 / 3	1.5 / 3	1.5 / 3	1.5 / 3.5	1.7 / 4.3	2.3 / 5.2	2.9 / 6.1
28	Simple	-	-	-	65	100	145	202	272	355
	Multiple	-	-	-	88	135	176	219	263	312
	Min. Bearing	-	-	-	1.5 / 3	1.5 / 3	1.5 / 3.2	1.5 / 4	2 / 4.8	2.5 / 5.6
30	Simple	-	-	-	52	80	116	162	219	286
	Multiple	-	-	-	70	108	152	188	226	268
	Min. Bearing	-	-	-	1.5 / 3	1.5 / 3	1.5 / 3	1.5 / 3.7	1.7 / 4.4	2.2 / 5.2
32	Simple	-	-	-	-	64	94	132	178	234
	Multiple	-	-	-	-	87	127	162	196	232
	Min. Bearing	-	-	-	-	1.5 / 3	1.5 / 3	1.5 / 3.4	1.5 / 4.1	1.9 / 4.8
34	Simple	-	-	-	-	52	77	108	146	192
	Multiple	-	-	-	-	71	104	142	171	203
	Min. Bearing	-	-	-	-	1.5 / 3	1.5 / 3	1.5 / 3.2	1.5 / 3.8	1.7 / 4.5
36	Simple	-	-	-	-	-	63	89	121	160
	Multiple	-	-	-	-	-	86	121	150	178
	Min. Bearing	-	-	-	-	-	1.5 / 3	1.5 / 3	1.5 / 3.6	1.5 / 4.3
38	Simple	-	-	-	-	-	52	74	101	134
	Multiple	-	-	-	-	-	72	101	133	158
	Min. Bearing	-	-	-	-	-	1.5 / 3	1.5 / 3	1.5 / 3.4	1.5 / 4
40	Simple	-	-	-	-	-	-	62	85	113
	Multiple	-	-	-	-	-	-	85	116	140
	Min. Bearing	-	-	-	-	-	-	1.5 / 3	1.5 / 3.2	1.5 / 3.8

- Both Architectural and Industrial appearance grade BOISE GLULAMS have the same structural grade, 24F-V4. Appearance grade does not affect the beam's load capacity.
- Uniform PLF load values are limited by shear, moment, total load deflection limited to L/180 and live load deflection limited to L/240.
- Live load no greater than 0.75 of total load.
- Span is measured center to center of the supports.
- Table values assume that lateral support is provided at each support and continuously along the compression edge of the beam.

- Table values for Minimum Required Bearing Lengths are based on the allowable compression design value perpendicular to grain for the beam and the load value shown. Other design considerations, such as a weaker support material, may warrant longer bearing lengths. Table values assume that support is provided across the full width of the beam.
- This table was designed to apply to a broad range of applications. It may be possible to exceed the limitations of this table by analyzing a specific application with the BC CALC® software.

# BOISE GLULAM® Beams Roof Load Tables

## Architectural Appearance Beams 5 1/8" Roof Load Tables – 125% Non-Snow

Span [ft]	24F-V4 Grade – 125% Load Duration In pounds per lineal foot (PLF)													
	Span Type	6"	7.5"	9"	10.5"	12"	13.5"	15"	16.5"	18"	19.5"	21"	22.5"	24"
6	Simple	1701	2660	3833	5219	6776	8132	9682	11471					
	Multiple	1309	2048	2952	4020	4924	5804	6772	7842					
	Min. Bearing	1.5 / 3	2.4 / 4.6	3.5 / 6.7	4.7 / 9.1	6.1 / 11.1	7.3 / 13.1	8.7 / 15.3	10.3 / 17.7					
8	Simple	953	1492	2151	2930	3829	4848	5987	7093	8126	9268			
	Multiple	733	1148	1655	2255	2948	3733	4508	5131	5798	6515			
	Min. Bearing	1.5 / 3	1.8 / 3.5	2.6 / 5	3.5 / 6.8	4.6 / 8.9	5.8 / 11.3	7.2 / 13.6	8.5 / 15.5	9.8 / 17.5	11.2 / 19.6			
10	Simple	485	952	1373	1870	2445	3097	3825	4630	5513	6472	7287		
	Multiple	467	731	1055	1439	1881	2383	2944	3565	4244	4748	5255		
	Min. Bearing	1.5 / 3	1.5 / 3	2.1 / 4	2.8 / 5.4	3.7 / 7.1	4.7 / 9	5.8 / 11.1	7 / 13.5	8.3 / 16	9.7 / 17.9	11 / 19.8		
12	Simple	277	547	950	1295	1693	2145	2651	3209	3821	4487	5206	5937	
	Multiple	322	505	730	995	1302	1650	2039	2469	2940	3453	4007	4499	
	Min. Bearing	1.5 / 3	1.5 / 3	1.7 / 3.3	2.4 / 4.5	3.1 / 5.9	3.9 / 7.5	4.8 / 9.3	5.8 / 11.2	6.9 / 13.3	8.1 / 15.7	9.4 / 18.2	10.7 / 20.4	
14	Simple	172	341	594	948	1240	1572	1942	2352	2802	3264	3759	4287	4848
	Multiple	228	369	533	728	953	1208	1493	1809	2154	2510	2891	3298	3730
	Min. Bearing	1.5 / 3	1.5 / 3	1.5 / 3	2 / 3.9	2.6 / 5.1	3.3 / 6.4	4.1 / 7.9	5 / 9.6	5.9 / 11.4	6.9 / 13.3	8 / 15.3	9.1 / 17.5	10.3 / 19.8
16	Simple	113	225	394	631	946	1199	1483	1788	2111	2460	2833	3232	3655
	Multiple	151	280	405	554	726	921	1139	1373	1622	1890	2178	2485	2811
	Min. Bearing	1.5 / 3	1.5 / 3	1.5 / 3	1.5 / 3.4	2.3 / 4.4	2.9 / 5.6	3.6 / 6.9	4.3 / 8.4	5.1 / 9.9	6 / 11.5	6.9 / 13.2	7.8 / 15.1	8.9 / 17.1
18	Simple	77	155	274	439	660	944	1160	1392	1644	1915	2207	2518	2848
	Multiple	103	207	318	435	570	724	889	1068	1262	1471	1695	1934	2188
	Min. Bearing	1.5 / 3	1.5 / 3	1.5 / 3	1.5 / 3	1.8 / 4	2.6 / 5	3.2 / 6.1	3.8 / 7.4	4.5 / 8.7	5.2 / 10.1	6 / 11.6	6.9 / 13.3	7.8 / 15
20	Simple	54	111	196	317	477	684	926	1111	1313	1530	1763	2012	2277
	Multiple	73	149	255	350	459	579	709	852	1007	1174	1353	1545	1748
	Min. Bearing	1.5 / 3	1.5 / 3	1.5 / 3	1.5 / 3	1.5 / 3.6	2.1 / 4.5	2.8 / 5.5	3.4 / 6.5	4 / 7.7	4.7 / 9	5.4 / 10.4	6.1 / 11.8	6.9 / 13.3
22	Simple	-	81	145	235	355	509	703	906	1071	1248	1439	1642	1858
	Multiple	-	109	194	287	375	471	577	694	820	957	1103	1259	1426
	Min. Bearing	-	1.5 / 3	1.5 / 3	1.5 / 3	1.5 / 3.2	1.7 / 4	2.4 / 4.9	3.1 / 5.9	3.6 / 7	4.2 / 8.1	4.8 / 9.3	5.5 / 10.6	6.2 / 12
24	Simple	-	60	109	178	270	389	537	720	888	1036	1194	1363	1543
	Multiple	-	82	147	238	310	389	478	574	679	793	915	1044	1182
	Min. Bearing	-	1.5 / 3	1.5 / 3	1.5 / 3	1.5 / 3	1.5 / 3.7	2 / 4.5	2.7 / 5.4	3.3 / 6.3	3.8 / 7.4	4.4 / 8.5	5 / 9.7	5.7 / 10.9
26	Simple	-	45	83	137	209	302	419	562	733	872	1005	1148	1300
	Multiple	-	63	113	184	260	327	401	482	571	666	769	878	995
	Min. Bearing	-	1.5 / 3	1.5 / 3	1.5 / 3	1.5 / 3	1.5 / 3.4	1.7 / 4.1	2.3 / 4.9	2.9 / 5.8	3.5 / 6.7	4 / 7.8	4.6 / 8.8	5.2 / 10
28	Simple	-	-	64	107	164	238	332	446	583	743	857	979	1108
	Multiple	-	-	88	145	220	277	340	410	485	567	654	748	847
	Min. Bearing	-	-	1.5 / 3	1.5 / 3	1.5 / 3	1.5 / 3.1	1.5 / 3.8	2 / 4.5	2.5 / 5.3	3.2 / 6.2	3.7 / 7.2	4.2 / 8.2	4.8 / 9.2
30	Simple	-	-	50	85	131	191	266	358	470	601	738	843	954
	Multiple	-	-	70	115	177	237	292	352	417	487	563	643	729
	Min. Bearing	-	-	1.5 / 3	1.5 / 3	1.5 / 3	1.5 / 3	1.5 / 3.5	1.7 / 4.2	2.2 / 4.9	2.8 / 5.8	3.4 / 6.6	3.9 / 7.6	4.4 / 8.5
32	Simple	-	-	-	67	105	154	216	292	383	491	618	732	830
	Multiple	-	-	-	93	143	205	253	305	361	422	488	558	633
	Min. Bearing	-	-	-	1.5 / 3	1.5 / 3	1.5 / 3	1.5 / 3.3	1.5 / 3.9	1.9 / 4.6	2.5 / 5.4	3.1 / 6.2	3.7 / 7	4.1 / 8
34	Simple	-	-	-	54	85	126	177	240	316	405	511	632	727
	Multiple	-	-	-	75	117	171	220	266	315	369	427	488	554
	Min. Bearing	-	-	-	1.5 / 3	1.5 / 3	1.5 / 3	1.5 / 3	1.5 / 3.7	1.7 / 4.3	2.2 / 5	2.7 / 5.8	3.4 / 6.6	3.9 / 7.4
36	Simple	-	-	-	-	69	103	146	199	262	338	426	528	641
	Multiple	-	-	-	-	96	141	193	233	277	324	375	430	488
	Min. Bearing	-	-	-	-	1.5 / 3	1.5 / 3	1.5 / 3	1.5 / 3.4	1.5 / 4	2 / 4.7	2.4 / 5.4	3 / 6.2	3.6 / 7
38	Simple	-	-	-	-	57	85	121	166	220	284	358	445	544
	Multiple	-	-	-	-	79	118	166	206	245	287	332	381	432
	Min. Bearing	-	-	-	-	1.5 / 3	1.5 / 3	1.5 / 3	1.5 / 3.2	1.5 / 3.8	1.8 / 4.4	2.2 / 5.1	2.7 / 5.8	3.3 / 6.6
40	Simple	-	-	-	-	47	71	101	139	185	240	303	377	462
	Multiple	-	-	-	-	66	98	139	183	218	255	296	339	385
	Min. Bearing	-	-	-	-	1.5 / 3	1.5 / 3	1.5 / 3	1.5 / 3.1	1.5 / 3.6	1.6 / 4.2	2 / 4.8	2.4 / 5.5	3 / 6.2

- Both Architectural and Industrial appearance grade BOISE GLULAMS have the same structural grade, 24F-V4. Appearance grade does not affect the beam's load capacity.
- Uniform PLF load values are limited by shear, moment, total load deflection limited to L/180 and live load deflection limited to L/240.
- Live load no greater than 0.75 of total load.
- Span is measured center to center of the supports.
- Table values assume that lateral support is provided at each support and continuously along the compression edge of the beam.
- Table values for Minimum Required Bearing Lengths are based on the allowable compression design value perpendicular to grain for the beam and the load value shown. Other design considerations, such as a weaker support material, may warrant longer bearing lengths. Table values assume that support is provided across the full width of the beam.
- This table was designed to apply to a broad range of applications. It may be possible to exceed the limitations of this table by analyzing a specific application with the BC CALC® software.

# BOISE GLULAM® Beams Roof Load Tables

## Architectural Appearance Beams 6¾" Roof Load Tables – 125% Non-Snow

### 24F-V4 Grade – 125% Load Duration In pounds per lineal foot (PLF)

Span [ft]	Span Type	24F-V4 Grade – 125% Load Duration In pounds per lineal foot (PLF)											
		7.5"	9"	10.5"	12"	13.5"	15"	16.5"	18"	19.5"	21"	22.5"	24"
6	Simple	3503	5048	6873	8924	10710	12752	15109					
	Multiple	2698	3888	5294	6485	7644	8919	10329					
	Min. Bearing	2.4 / 4.6	3.5 / 6.7	4.7 / 9.1	6.1 / 11.1	7.3 / 13.1	8.7 / 15.3	10.3 / 17.7					
8	Simple	1965	2833	3859	5043	6385	7886	9343	10703	12207			
	Multiple	1512	2180	2971	3883	4917	5938	6758	7637	8581			
	Min. Bearing	1.8 / 3.5	2.6 / 5	3.5 / 6.8	4.6 / 8.9	5.8 / 11.3	7.2 / 13.6	8.5 / 15.5	9.8 / 17.5	11.2 / 19.6			
10	Simple	1253	1808	2463	3220	4078	5038	6099	7260	8507	9597		
	Multiple	963	1390	1895	2478	3139	3878	4695	5590	6253	6922		
	Min. Bearing	1.5 / 3	2.1 / 4	2.8 / 5.4	3.7 / 7.1	4.7 / 9	5.8 / 11.1	7 / 13.5	8.3 / 16	9.7 / 17.9	11 / 19.8		
12	Simple	720	1251	1705	2230	2826	3491	4212	4972	5791	6669	7605	8600
	Multiple	665	961	1311	1715	2173	2685	3241	3826	4457	5133	5854	6465
	Min. Bearing	1.5 / 3	1.7 / 3.3	2.4 / 4.5	3.1 / 5.9	3.9 / 7.5	4.8 / 9.3	5.8 / 11.2	6.8 / 13.2	8 / 15.3	9.2 / 17.7	10.5 / 20.1	11.8 / 22.2
14	Simple	449	782	1248	1633	2070	2534	3040	3589	4181	4815	5492	6211
	Multiple	485	702	958	1255	1591	1948	2337	2760	3215	3704	4225	4778
	Min. Bearing	1.5 / 3	1.5 / 3	2 / 3.9	2.6 / 5.1	3.3 / 6.4	4.1 / 7.9	4.9 / 9.4	5.8 / 11.1	6.7 / 13	7.7 / 14.9	8.8 / 17	10 / 19.2
16	Simple	297	519	831	1245	1560	1909	2290	2704	3151	3629	4140	4682
	Multiple	369	534	730	956	1198	1466	1759	2078	2421	2790	3183	3600
	Min. Bearing	1.5 / 3	1.5 / 3	1.5 / 3.4	2.3 / 4.4	2.9 / 5.6	3.5 / 6.8	4.2 / 8.1	5 / 9.6	5.8 / 11.2	6.7 / 12.9	7.6 / 14.7	8.6 / 16.6
18	Simple	205	360	578	869	1214	1485	1782	2105	2453	2826	3225	3648
	Multiple	273	419	573	742	930	1139	1368	1616	1884	2171	2477	2803
	Min. Bearing	1.5 / 3	1.5 / 3	1.5 / 3	1.8 / 3.9	2.5 / 4.9	3.1 / 6	3.7 / 7.2	4.4 / 8.4	5.1 / 9.8	5.9 / 11.3	6.7 / 12.9	7.6 / 14.6
20	Simple	146	259	417	628	900	1185	1423	1681	1960	2259	2577	2916
	Multiple	196	336	456	591	741	908	1091	1289	1503	1733	1978	2239
	Min. Bearing	1.5 / 3	1.5 / 3	1.5 / 3	1.5 / 3.5	2.1 / 4.4	2.8 / 5.3	3.3 / 6.4	3.9 / 7.5	4.5 / 8.7	5.2 / 10.1	6 / 11.5	6.7 / 13
22	Simple	107	191	309	467	671	926	1160	1371	1599	1843	2103	2380
	Multiple	144	255	370	480	603	739	888	1050	1225	1412	1613	1825
	Min. Bearing	1.5 / 3	1.5 / 3	1.5 / 3	1.5 / 3.1	1.7 / 3.9	2.4 / 4.8	3 / 5.7	3.5 / 6.8	4.1 / 7.9	4.7 / 9.1	5.4 / 10.3	6.1 / 11.7
24	Simple	79	143	234	355	512	708	948	1137	1326	1529	1746	1976
	Multiple	108	193	306	397	498	611	735	870	1015	1171	1337	1514
	Min. Bearing	1.5 / 3	1.5 / 3	1.5 / 3	1.5 / 3	1.5 / 3.6	2 / 4.3	2.7 / 5.2	3.2 / 6.1	3.7 / 7.2	4.3 / 8.2	4.9 / 9.4	5.5 / 10.6
26	Simple	60	110	180	275	398	551	740	957	1116	1287	1470	1664
	Multiple	82	149	243	332	418	513	617	731	853	984	1125	1274
	Min. Bearing	1.5 / 3	1.5 / 3	1.5 / 3	1.5 / 3	1.5 / 3.3	1.7 / 4	2.3 / 4.8	2.9 / 5.6	3.4 / 6.6	3.9 / 7.5	4.5 / 8.6	5 / 9.7
28	Simple	45	85	141	216	314	437	587	767	951	1097	1253	1419
	Multiple	64	116	191	281	354	436	524	621	725	838	957	1084
	Min. Bearing	1.5 / 3	1.5 / 3	1.5 / 3	1.5 / 3	1.5 / 3	1.5 / 3.7	2 / 4.4	2.5 / 5.2	3.1 / 6	3.6 / 7	4.1 / 7.9	4.7 / 9
30	Simple	-	66	111	172	251	350	472	618	792	944	1079	1222
	Multiple	-	92	152	233	304	373	450	533	623	720	823	933
	Min. Bearing	-	1.5 / 3	1.5 / 3	1.5 / 3	1.5 / 3	1.5 / 3.4	1.7 / 4.1	2.2 / 4.8	2.8 / 5.6	3.3 / 6.4	3.8 / 7.4	4.3 / 8.3
32	Simple	-	52	89	139	203	284	384	504	647	813	937	1062
	Multiple	-	73	122	188	262	323	390	462	540	624	714	810
	Min. Bearing	-	1.5 / 3	1.5 / 3	1.5 / 3	1.5 / 3	1.5 / 3.2	1.5 / 3.8	1.9 / 4.5	2.5 / 5.2	3.1 / 6	3.6 / 6.8	4 / 7.7
34	Simple	-	-	71	112	166	233	316	416	534	672	821	930
	Multiple	-	-	99	154	225	281	340	403	472	546	624	708
	Min. Bearing	-	-	1.5 / 3	1.5 / 3	1.5 / 3	1.5 / 3	1.5 / 3.6	1.7 / 4.2	2.2 / 4.9	2.7 / 5.6	3.3 / 6.4	3.8 / 7.2
36	Simple	-	-	57	91	136	192	262	345	445	561	696	821
	Multiple	-	-	81	126	186	247	298	354	415	480	550	624
	Min. Bearing	-	-	1.5 / 3	1.5 / 3	1.5 / 3	1.5 / 3	1.5 / 3.3	1.5 / 3.9	2 / 4.6	2.4 / 5.3	3 / 6	3.5 / 6.8
38	Simple	-	-	46	75	112	160	219	289	373	472	586	716
	Multiple	-	-	66	105	155	218	263	313	367	425	487	552
	Min. Bearing	-	-	1.5 / 3	1.5 / 3	1.5 / 3	1.5 / 3	1.5 / 3.1	1.5 / 3.7	1.8 / 4.3	2.2 / 5	2.7 / 5.7	3.3 / 6.4
40	Simple	-	-	-	61	93	134	183	244	316	400	497	609
	Multiple	-	-	-	87	130	183	234	278	326	378	433	492
	Min. Bearing	-	-	-	1.5 / 3	1.5 / 3	1.5 / 3	1.5 / 3	1.5 / 3.5	1.6 / 4.1	2 / 4.7	2.4 / 5.4	3 / 6.1

- Both Architectural and Industrial appearance grade BOISE GLULAMS have the same structural grade, 24F-V4. Appearance grade does not affect the beam's load capacity.
- Uniform PLF load values are limited by shear, moment, total load deflection limited to L/180 and live load deflection limited to L/240.
- Live load no greater than 0.75 of total load.
- Span is measured center to center of the supports.
- Table values assume that lateral support is provided at each support and continuously along the compression edge of the beam.
- Table values for Minimum Required Bearing Lengths are based on the allowable compression design value perpendicular to grain for the beam and the load value shown. Other design considerations, such as a weaker support material, may warrant longer bearing lengths. Table values assume that support is provided across the full width of the beam.
- This table was designed to apply to a broad range of applications. It may be possible to exceed the limitations of this table by analyzing a specific application with the BC CALC® software.

# BOISE GLULAM® Beams Roof Load Tables

## Architectural Appearance Beams 8 3/4" Roof Load Tables – 125% Non-Snow

Span [ft]	24F-V4 Grade – 125% Load Duration In pounds per lineal foot (PLF)											
	Span Type	9"	10.5"	12"	13.5"	15"	16.5"	18"	19.5"	21"	22.5"	24"
6	Simple	6543	8910	11568	13884	16531	19585	23149	27362	32418	38598	46324
	Multiple	5039	6863	8406	9909	11562	13389	15420	17690	20244	23140	26449
	Min. Bearing	3.5 / 6.7	4.7 / 9.1	6.1 / 11.1	7.3 / 13.1	8.7 / 15.3	10.3 / 17.7	12.2 / 20.4	14.5 / 23.4	17.1 / 26.8	20.4 / 30.6	24.5 / 34.9
8	Simple	3672	5002	6537	8277	10222	12111	13874	15824	17990	20412	23136
	Multiple	2826	3851	5033	6374	7697	8760	9899	11123	12441	13865	15407
	Min. Bearing	2.6 / 5	3.5 / 6.8	4.6 / 8.9	5.8 / 11.3	7.2 / 13.6	8.5 / 15.5	9.8 / 17.5	11.2 / 19.6	12.7 / 22	14.4 / 24.5	16.3 / 27.2
10	Simple	2343	3193	4174	5287	6520	7818	9226	10745	12372	13865	15407
	Multiple	1802	2456	3212	4069	5019	6018	7103	8105	8973	9890	10861
	Min. Bearing	2.1 / 4	2.8 / 5.4	3.7 / 7.1	4.7 / 9	5.8 / 11.1	6.9 / 13.3	8.1 / 15.7	9.5 / 17.9	10.9 / 19.8	12.2 / 21.8	13.6 / 24
12	Simple	1621	2211	2891	3628	4436	5320	6279	7313	8422	9605	10861
	Multiple	1246	1699	2223	2790	3412	4092	4831	5628	6482	7393	8361
	Min. Bearing	1.7 / 3.3	2.4 / 4.5	3.1 / 5.9	3.9 / 7.4	4.7 / 9.1	5.6 / 10.9	6.7 / 12.8	7.8 / 15	8.9 / 17.2	10.2 / 19.6	11.5 / 22.2
14	Simple	1014	1618	2090	2617	3200	3839	4532	5280	6081	6936	7844
	Multiple	910	1242	1605	2011	2460	2951	3485	4060	4677	5335	6034
	Min. Bearing	1.5 / 3	2 / 3.9	2.6 / 5	3.3 / 6.3	4 / 7.7	4.8 / 9.2	5.6 / 10.8	6.5 / 12.6	7.5 / 14.5	8.6 / 16.6	9.7 / 18.7
16	Simple	673	1077	1573	1970	2410	2892	3414	3978	4583	5228	5913
	Multiple	692	933	1206	1512	1850	2221	2623	3057	3522	4019	4546
	Min. Bearing	1.5 / 3	1.5 / 3.4	2.2 / 4.3	2.8 / 5.4	3.4 / 6.6	4.1 / 7.9	4.9 / 9.4	5.7 / 10.9	6.5 / 12.5	7.4 / 14.3	8.4 / 16.2
18	Simple	467	750	1127	1532	1875	2250	2658	3098	3569	4072	4606
	Multiple	538	724	936	1174	1438	1726	2040	2378	2741	3128	3539
	Min. Bearing	1.5 / 3	1.5 / 3	1.8 / 3.8	2.5 / 4.8	3 / 5.8	3.6 / 7	4.3 / 8.2	5 / 9.6	5.7 / 11	6.5 / 12.6	7.4 / 14.2
20	Simple	335	540	814	1167	1496	1797	2123	2474	2852	3254	3682
	Multiple	427	576	745	936	1146	1377	1627	1898	2188	2497	2826
	Min. Bearing	1.5 / 3	1.5 / 3	1.5 / 3.4	2.1 / 4.2	2.7 / 5.2	3.2 / 6.2	3.8 / 7.3	4.4 / 8.5	5.1 / 9.8	5.8 / 11.2	6.6 / 12.6
22	Simple	247	400	606	870	1201	1464	1731	2018	2326	2655	3005
	Multiple	331	467	606	761	932	1121	1325	1546	1783	2036	2304
	Min. Bearing	1.5 / 3	1.5 / 3	1.5 / 3.1	1.7 / 3.8	2.4 / 4.7	2.9 / 5.6	3.4 / 6.6	4 / 7.7	4.6 / 8.8	5.2 / 10.1	5.9 / 11.4
24	Simple	186	303	461	663	918	1214	1435	1674	1930	2204	2494
	Multiple	251	386	500	629	771	928	1098	1281	1478	1688	1911
	Min. Bearing	1.5 / 3	1.5 / 3	1.5 / 3	1.5 / 3.5	2 / 4.2	2.6 / 5.1	3.1 / 6	3.6 / 7	4.2 / 8	4.8 / 9.2	5.4 / 10.3
26	Simple	142	234	357	516	715	959	1207	1409	1625	1855	2101
	Multiple	193	315	419	527	647	779	922	1076	1242	1419	1607
	Min. Bearing	1.5 / 3	1.5 / 3	1.5 / 3	1.5 / 3.2	1.7 / 3.9	2.3 / 4.7	2.8 / 5.5	3.3 / 6.4	3.8 / 7.4	4.4 / 8.4	4.9 / 9.5
28	Simple	110	183	281	407	566	761	995	1200	1384	1581	1790
	Multiple	151	247	355	447	549	661	783	915	1057	1208	1368
	Min. Bearing	1.5 / 3	1.5 / 3	1.5 / 3	1.5 / 3	1.5 / 3.6	2 / 4.3	2.5 / 5.1	3.1 / 5.9	3.5 / 6.8	4 / 7.7	4.5 / 8.7
30	Simple	86	144	223	326	454	612	802	1027	1191	1361	1542
	Multiple	119	197	302	383	471	567	673	786	908	1038	1177
	Min. Bearing	1.5 / 3	1.5 / 3	1.5 / 3	1.5 / 3	1.5 / 3.3	1.7 / 4	2.2 / 4.7	2.8 / 5.5	3.3 / 6.3	3.7 / 7.2	4.2 / 8.1
32	Simple	67	115	180	263	369	498	654	839	1035	1183	1340
	Multiple	95	158	244	331	407	491	583	681	787	901	1021
	Min. Bearing	1.5 / 3	1.5 / 3	1.5 / 3	1.5 / 3	1.5 / 3.1	1.5 / 3.7	1.9 / 4.4	2.5 / 5.1	3 / 5.9	3.5 / 6.7	3.9 / 7.5
34	Simple	53	92	145	215	302	409	539	692	872	1036	1174
	Multiple	76	128	199	288	355	428	508	595	688	787	893
	Min. Bearing	1.5 / 3	1.5 / 3	1.5 / 3	1.5 / 3	1.5 / 3	1.5 / 3.5	1.7 / 4.1	2.2 / 4.8	2.7 / 5.5	3.2 / 6.2	3.7 / 7.1
36	Simple	42	74	119	176	249	339	448	577	727	902	1035
	Multiple	61	105	164	241	311	376	446	523	605	693	786
	Min. Bearing	1.5 / 3	1.5 / 3	1.5 / 3	1.5 / 3	1.5 / 3	1.5 / 3.3	1.5 / 3.8	2 / 4.5	2.4 / 5.1	3 / 5.9	3.4 / 6.6
38	Simple	-	60	97	146	207	283	375	484	612	759	919
	Multiple	-	86	136	201	274	332	394	462	535	613	696
	Min. Bearing	-	1.5 / 3	1.5 / 3	1.5 / 3	1.5 / 3	1.5 / 3.1	1.5 / 3.6	1.8 / 4.2	2.2 / 4.8	2.7 / 5.5	3.2 / 6.2
40	Simple	-	48	79	121	173	238	316	409	518	644	789
	Multiple	-	70	113	168	238	294	350	411	476	546	620
	Min. Bearing	-	1.5 / 3	1.5 / 3	1.5 / 3	1.5 / 3	1.5 / 3	1.5 / 3.4	1.6 / 4	2 / 4.6	2.4 / 5.2	3 / 5.9

- Both Architectural and Industrial appearance grade BOISE GLULAMS have the same structural grade, 24F-V4. Appearance grade does not affect the beam's load capacity.
- Uniform PLF load values are limited by shear, moment, total load deflection limited to L/180 and live load deflection limited to L/240.
- Live load no greater than 0.75 of total load.
- Span is measured center to center of the supports.
- Table values assume that lateral support is provided at each support and continuously along the compression edge of the beam.
- Table values for Minimum Required Bearing Lengths are based on the allowable compression design value perpendicular to grain for the beam and the load value shown. Other design considerations, such as a weaker support material, may warrant longer bearing lengths. Table values assume that support is provided across the full width of the beam.
- This table was designed to apply to a broad range of applications. It may be possible to exceed the limitations of this table by analyzing a specific application with the BC CALC® software.

# BOISE GLULAM® Beams Roof Load Tables

## Industrial Appearance Headers 3 1/2" and 5 1/2" Roof Load Tables – 125% Non-Snow

		24F-V4 Grade – 125% Load Duration In pounds per lineal foot (PLF)													
Span [ft]	Span Type	3 1/2"								5 1/2"					
		4.5"	6"	7.5"	9"	10.5"	12"	13.5"	15"	9"	10.5"	12"	13.5"	15"	
6	Simple	652	1162	1817	2617	3564	4627	5554	6612	4113	5601	7271	8727	10391	
	Multiple	502	894	1399	2016	2745	3363	3964	4625	3168	4314	5284	6228	7267	
	Min. Bearing	1.5 / 3	1.5 / 3	2.4 / 4.6	3.5 / 6.7	4.7 / 9.1	6.1 / 11.1	7.3 / 13.1	8.7 / 15.3	3.5 / 6.7	4.7 / 9.1	6.1 / 11.1	7.3 / 13.1	8.7 / 15.3	
8	Simple	273	651	1019	1469	2001	2615	3311	4089	2308	3144	4109	5203	6425	
	Multiple	281	501	784	1131	1540	2013	2549	3079	1777	2420	3164	4006	4838	
	Min. Bearing	1.5 / 3	1.5 / 3	1.8 / 3.5	2.6 / 5	3.5 / 6.8	4.6 / 8.9	5.8 / 11.3	7.2 / 13.6	2.6 / 5	3.5 / 6.8	4.6 / 8.9	5.8 / 11.3	7.2 / 13.6	
10	Simple	138	331	650	937	1277	1670	2115	2612	1473	2007	2624	3323	4105	
	Multiple	178	319	499	721	983	1285	1627	2011	1133	1544	2019	2557	3160	
	Min. Bearing	1.5 / 3	1.5 / 3	1.5 / 3	2.1 / 4	2.8 / 5.4	3.7 / 7.1	4.7 / 9	5.8 / 11.1	2.1 / 4	2.8 / 5.4	3.7 / 7.1	4.7 / 9	5.8 / 11.1	
12	Simple	78	189	373	649	884	1156	1465	1810	1019	1390	1817	2302	2845	
	Multiple	104	220	345	498	680	889	1127	1392	783	1068	1397	1771	2188	
	Min. Bearing	1.5 / 3	1.5 / 3	1.5 / 3	1.7 / 3.3	2.4 / 4.5	3.1 / 5.9	3.9 / 7.5	4.8 / 9.3	1.7 / 3.3	2.4 / 4.5	3.1 / 5.9	3.9 / 7.5	4.8 / 9.3	
14	Simple	48	117	233	406	647	847	1073	1327	637	1017	1331	1687	2085	
	Multiple	64	156	252	364	497	651	825	1020	572	781	1022	1296	1602	
	Min. Bearing	1.5 / 3	1.5 / 3	1.5 / 3	1.5 / 3	2 / 3.9	2.6 / 5.1	3.3 / 6.4	4.1 / 7.9	1.5 / 3	2 / 3.9	2.6 / 5.1	3.3 / 6.4	4.1 / 7.9	
16	Simple	-	77	154	269	431	646	819	1013	423	677	1015	1287	1588	
	Multiple	-	103	191	277	378	496	629	778	435	595	779	988	1219	
	Min. Bearing	-	1.5 / 3	1.5 / 3	1.5 / 3	1.5 / 3.4	2.3 / 4.4	2.9 / 5.6	3.6 / 6.9	1.5 / 3	1.5 / 3.4	2.3 / 4.4	2.9 / 5.6	3.6 / 6.9	
18	Simple	-	53	106	187	300	451	645	797	294	471	708	1010	1235	
	Multiple	-	71	142	217	297	389	494	612	341	467	612	774	948	
	Min. Bearing	-	1.5 / 3	1.5 / 3	1.5 / 3	1.5 / 3	1.8 / 4	2.6 / 5	3.2 / 6.2	1.5 / 3	1.5 / 3	1.8 / 4	2.6 / 5	3.2 / 6.1	
20	Simple	-	-	76	134	216	326	467	643	211	340	512	734	986	
	Multiple	-	-	102	174	239	314	398	493	274	375	492	617	756	
	Min. Bearing	-	-	1.5 / 3	1.5 / 3	1.5 / 3	1.5 / 3.6	2.1 / 4.5	2.9 / 5.6	1.5 / 3	1.5 / 3	1.5 / 3.5	2.1 / 4.4	2.8 / 5.4	
22	Simple	-	-	55	99	160	242	348	480	155	252	381	547	755	
	Multiple	-	-	75	132	196	257	327	405	208	308	400	502	615	
	Min. Bearing	-	-	1.5 / 3	1.5 / 3	1.5 / 3	1.5 / 3.2	1.7 / 4.1	2.4 / 5.1	1.5 / 3	1.5 / 3	1.5 / 3.2	1.7 / 4	2.4 / 4.9	
24	Simple	-	-	41	74	121	184	265	367	117	191	290	417	577	
	Multiple	-	-	56	100	162	215	273	339	158	255	330	415	509	
	Min. Bearing	-	-	1.5 / 3	1.5 / 3	1.5 / 3	1.5 / 3	1.5 / 3.8	2 / 4.6	1.5 / 3	1.5 / 3	1.5 / 3	1.5 / 3.6	2 / 4.4	
26	Simple	-	-	-	57	94	143	206	286	89	147	224	324	449	
	Multiple	-	-	-	77	126	181	231	285	121	198	277	348	427	
	Min. Bearing	-	-	-	1.5 / 3	1.5 / 3	1.5 / 3	1.5 / 3.5	1.7 / 4.3	1.5 / 3	1.5 / 3	1.5 / 3	1.5 / 3.3	1.7 / 4.1	
28	Simple	-	-	-	44	73	112	163	226	69	115	176	256	356	
	Multiple	-	-	-	60	99	151	197	242	95	156	234	295	363	
	Min. Bearing	-	-	-	1.5 / 3	1.5 / 3	1.5 / 3	1.5 / 3.2	1.5 / 3.9	1.5 / 3	1.5 / 3	1.5 / 3	1.5 / 3.1	1.5 / 3.7	
30	Simple	-	-	-	-	58	89	130	182	54	91	140	205	286	
	Multiple	-	-	-	-	79	121	169	208	75	124	190	253	311	
	Min. Bearing	-	-	-	-	1.5 / 3	1.5 / 3	1.5 / 3	1.5 / 3.6	1.5 / 3	1.5 / 3	1.5 / 3	1.5 / 3	1.5 / 3.5	
32	Simple	-	-	-	-	46	72	105	147	42	72	113	165	232	
	Multiple	-	-	-	-	63	98	142	180	59	100	154	219	269	
	Min. Bearing	-	-	-	-	1.5 / 3	1.5 / 3	1.5 / 3	1.5 / 3.4	1.5 / 3	1.5 / 3	1.5 / 3	1.5 / 3	1.5 / 3.2	
34	Simple	-	-	-	-	-	58	86	121	-	58	91	135	190	
	Multiple	-	-	-	-	-	80	117	157	-	81	125	183	234	
	Min. Bearing	-	-	-	-	-	1.5 / 3	1.5 / 3	1.5 / 3.2	-	1.5 / 3	1.5 / 3	1.5 / 3	1.5 / 3	
36	Simple	-	-	-	-	-	47	71	100	-	47	74	111	157	
	Multiple	-	-	-	-	-	66	96	135	-	66	103	151	206	
	Min. Bearing	-	-	-	-	-	1.5 / 3	1.5 / 3	1.5 / 3	-	1.5 / 3	1.5 / 3	1.5 / 3	1.5 / 3	
38	Simple	-	-	-	-	-	-	58	83	-	-	61	92	130	
	Multiple	-	-	-	-	-	-	80	113	-	-	85	126	178	
	Min. Bearing	-	-	-	-	-	-	1.5 / 3	1.5 / 3	-	-	1.5 / 3	1.5 / 3	1.5 / 3	
40	Simple	-	-	-	-	-	-	48	69	-	-	50	76	109	
	Multiple	-	-	-	-	-	-	67	95	-	-	71	106	149	
	Min. Bearing	-	-	-	-	-	-	1.5 / 3	1.5 / 3	-	-	1.5 / 3	1.5 / 3	1.5 / 3	

- Both Architectural and Industrial appearance grade BOISE GLULAMS have the same structural grade, 24F-V4. Appearance grade does not affect the beam's load capacity.
- Uniform PLF load values are limited by shear, moment, total load deflection limited to L/180 and live load deflection limited to L/240.
- Live load no greater than 0.75 of total load.
- Span is measured center to center of the supports.
- Table values assume that lateral support is provided at each support and continuously along the compression edge of the beam.
- Table values for Minimum Required Bearing Lengths are based on the allowable compression design value perpendicular to grain for the beam and the load value shown. Other design considerations, such as a weaker support material, may warrant longer bearing lengths. Table values assume that support is provided across the full width of the beam.
- This table was designed to apply to a broad range of applications. It may be possible to exceed the limitations of this table by analyzing a specific application with the BC CALC® software.

## GENERAL NOTES

- Continuous lateral support at the top of the beam is assumed.
- Minimum 3 inch end bearing or see BC CALC® software requirements.
- Bearing length specifications assume bearing across the full width of the beams and are based upon the glulam's allowable compression perpendicular to grain value.
- Table assumes uniform loading on worst case of simple or multiple beam span applications for all tables.
- Longer bearing lengths may be required depending upon support conditions, use BC CALC® sizing software for analysis.
- Multiple member beams require proper connection schedules.
- Dry-use conditions are assumed.
- It may be possible to exceed the limitations of this table by analyzing a specific application with the BC CALC® software.

### Ridge Beam (see page 28)

- Deflection is limited to L/240 live load and L/180 total load.
- Table based upon either simple or continuous beam span conditions.

### Floor Notes (see pages 25, 26, 29)

- Floor loads are 40 psf live load and 12 psf dead load. Floor live load has been reduced per area provisions in accordance with the model building codes.
- Floor joist spans may be either simple or continuous. Mid-span support of floor joists may vary up to 4'-0" from centerline of building.
- Deflection is limited to L/360 live load and L/240 total load, consult governing building code for local provisions.
- Tables assume a wall load of 100 plf (pages 26 and 29).
- Interior floor support may vary a maximum of 4 feet from centerline (page 29).

### Roof Notes (see pages 27, 28 & 29)

- Always use roof live and dead loads that meet or exceed the required design loading.
- No roof load reductions have been taken.

### Header (Roof) (see pages 27 & 29)

- Deflection is limited to L/240 live load and L/180 total load.
- Table assumes 2'-0" roof overhang.

## One Floor Beam Span Tables

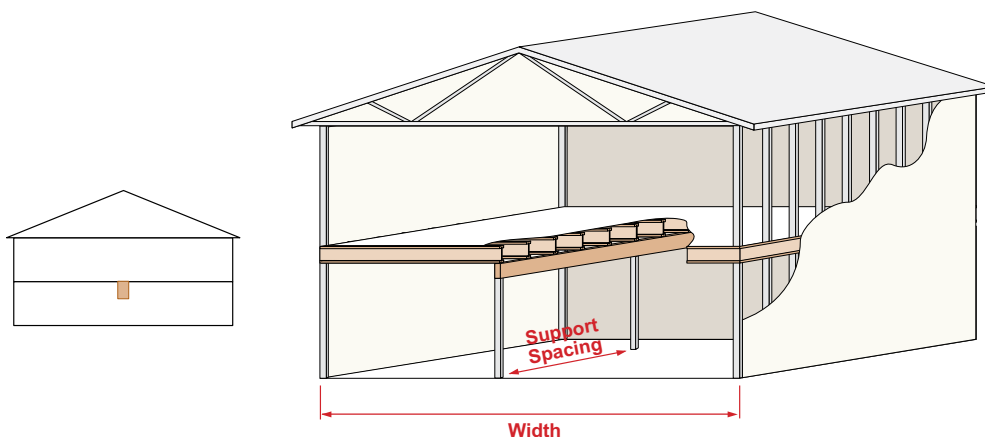

### Required Beam Depths and Bearing Lengths [in]

Load Duration %	Floor Load [psf]		Beam Support Spacing [Feet]	Width of Building Segment [feet]											
	Live	Dead		KEY: Beam Breadth [in] X Beam Depth [in]		End Support / Intermediate Support Bearing Length Requirements [in]									
				24	28	32	36	40	44						
100%	40	12	12	3.125 x 13.5	2.4/5.8	3.125 x 15	2.7/6.8	3.125 x 16.5	3.1/7.7	3.125 x 16.5	3.5/8.7	3.125 x 18	3.9/9.6	3.125 x 18	4.3/10.6
				5.125 x 10.5	1.5/3.6	5.125 x 12	1.7/4.1	5.125 x 12	1.9/4.7	5.125 x 13.5	2.2/5.3	5.125 x 13.5	2.4/5.9	5.125 x 15	2.6/6.5
			14	3.125 x 16.5	2.7/6.8	3.125 x 18	3.2/7.9	3.125 x 18	3.6/9.0	5.125 x 15	2.5/6.2	5.125 x 16.5	2.8/6.9	5.125 x 16.5	3.1/7.6
				5.125 x 13.5	1.7/4.1	5.125 x 13.5	2.0/4.8	5.125 x 15	2.2/5.5	6.75 x 13.5	1.9/4.7	6.75 x 13.5	2.1/5.2	6.75 x 15	2.3/5.8
			16	3.5 x 18	3.1/7.7	5.125 x 15	2.2/5.5	5.125 x 16.5	2.5/6.3	5.125 x 16.5	2.9/7.1	5.125 x 18	3.2/7.9	5.125 x 18	3.5/8.6
				5.125 x 15	1.9/4.7	6.75 x 13.5	1.7/4.2	6.75 x 15	1.9/4.8	6.75 x 15	2.2/5.5	6.75 x 15	2.4/6.0	6.75 x 16.5	2.7/6.6
			18	5.125 x 16.5	2.2/5.3	5.125 x 18	2.5/6.2	5.125 x 18	2.9/7.1	5.125 x 19.5	3.2/8.0	5.125 x 19.5	3.6/8.8	5.125 x 21	3.9/9.7
				6.75 x 15	1.6/4.0	6.75 x 15	1.9/4.7	6.75 x 16.5	2.2/5.4	6.75 x 16.5	2.4/6.0	6.75 x 18	2.7/6.7	6.75 x 18	3.0/7.4
			20	5.125 x 18	2.3/5.8	5.125 x 19.5	2.8/6.9	5.125 x 19.5	3.2/7.9	5.125 x 21	3.6/8.8	5.125 x 21	4.0/9.8	5.125 x 22.5	4.8/11.9
				6.75 x 16.5	1.8/4.5	6.75 x 16.5	2.1/5.2	6.75 x 18	2.4/6.0	6.75 x 18	2.7/6.7	6.75 x 19.5	3.0/7.5	6.75 x 19.5	3.3/8.2
			22	5.125 x 19.5	2.6/6.3	5.125 x 21	3.1/7.6	5.125 x 22.5	3.5/8.6	5.125 x 22.5	3.9/9.7	5.125 x 24	4.3/10.8	6.75 x 22.5	3.6/9.0
				6.75 x 18	2.0/4.9	6.75 x 18	2.3/5.8	6.75 x 19.5	2.7/6.6	6.75 x 21	3.0/7.4	6.75 x 21	3.3/8.2		
			24	5.125 x 21	2.8/6.9	5.125 x 22.5	3.3/8.2	5.125 x 24	3.8/9.4	6.75 x 22.5	3.2/8	6.75 x 22.5	3.6/8.9	6.75 x 24	4.0/9.8
				6.75 x 19.5	2.2/5.4	6.75 x 19.5	2.5/6.3	6.75 x 21	2.9/7.2						

## Two Floor Beam Span Tables

See General Notes on page 25.

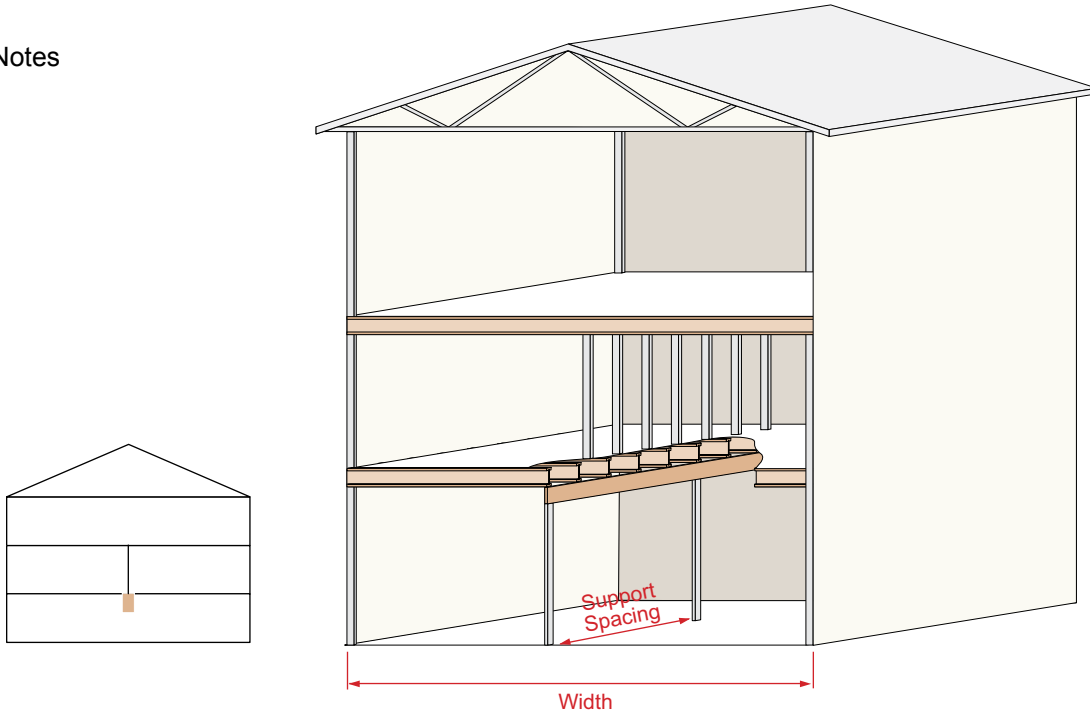

### Required Beam Depths and Bearing Lengths [in]

Load Duration %	Floor Load [psf]		Beam Support Spacing [Feet]	Width of Building Segment [feet]											
	Live	Dead		KEY: Beam Breadth [in] X Beam Depth [in] End Support / Intermediate Support Bearing Length Requirements [in]											
				24	28	32	36	40	44						
100%	40	12	6	3.125 x 10.5	2.1 / 5.2	3.125 x 12	2.5 / 6.2	3.125 x 12	2.9 / 7.1	3.125 x 13.5	3.2 / 7.9	3.125 x 15	3.5 / 8.7	3.125 x 15	3.8 / 9.5
				5.125 x 9	1.5 / 3.2	5.125 x 9	1.5 / 3.8	5.125 x 9	1.8 / 4.3	5.125 x 10.5	2.0 / 4.8	5.125 x 10.5	2.2 / 5.3	5.125 x 10.5	2.4 / 5.8
			8	3.125 x 13.5	2.8 / 6.9	3.125 x 15	3.2 / 8	3.125 x 15	3.7 / 9.1	3.125 x 16.5	4.1 / 10.1	3.125 x 18	4.5 / 11.1	5.125 x 13.5	3.0 / 7.3
				5.125 x 10.5	1.7 / 4.2	5.125 x 12	2.0 / 4.9	5.125 x 12	2.3 / 5.6	5.125 x 12	2.5 / 6.2	5.125 x 13.5	2.7 / 6.8	6.75 x 12	2.3 / 5.6
			10	3.125 x 16.5	3.4 / 8.4	3.125 x 16.5	3.9 / 9.7	5.125 x 15	2.7 / 6.7	5.125 x 15	3.0 / 7.4	5.125 x 16.5	3.3 / 8.1	5.125 x 16.5	3.5 / 8.7
				5.125 x 12	2.1 / 5.2	5.125 x 13.5	2.4 / 6	6.75 x 12	2.1 / 5.1	6.75 x 13.5	2.3 / 5.6	6.75 x 13.5	2.5 / 6.1	6.75 x 15	2.7 / 6.6
			12	5.125 x 15	2.4 / 6	5.125 x 16.5	2.8 / 6.9	5.125 x 16.5	3.1 / 7.8	5.125 x 18	3.4 / 8.5	5.125 x 18	3.7 / 9.2	5.125 x 19.5	4.0 / 9.8
				6.75 x 13.5	1.9 / 4.6	6.75 x 13.5	2.1 / 5.3	6.75 x 15	2.4 / 5.9	6.75 x 15	2.6 / 6.5	6.75 x 16.5	2.8 / 7	6.75 x 16.5	3.0 / 7.5
			14	5.125 x 16.5	2.8 / 6.9	5.125 x 18	3.2 / 7.8	5.125 x 19.5	3.5 / 8.7	5.125 x 19.5	3.8 / 9.5	5.125 x 21	4.1 / 10.2	5.125 x 21	4.3 / 10.8
				6.75 x 15	2.1 / 5.2	6.75 x 16.5	2.4 / 6	6.75 x 16.5	2.7 / 6.6	6.75 x 18	2.9 / 7.2	6.75 x 18	3.1 / 7.7	6.75 x 19.5	3.3 / 8.2
			16	5.125 x 19.5	3.1 / 7.6	5.125 x 21	3.5 / 8.7	5.125 x 21	3.9 / 9.6	5.125 x 22.5	4.2 / 10.4	5.125 x 22.5	4.4 / 11	5.125 x 24	4.7 / 11.6
				6.75 x 16.5	2.4 / 5.8	6.75 x 18	2.7 / 6.6	6.75 x 19.5	2.9 / 7.3	6.75 x 19.5	3.2 / 7.9	6.75 x 21	3.4 / 8.4	6.75 x 21	3.5 / 8.8
			18	5.125 x 21	3.4 / 8.4	5.125 x 22.5	3.8 / 9.4	5.125 x 24	4.2 / 10.3	5.125 x 24	4.5 / 11.1	6.75 x 22.5	3.6 / 8.9	6.75 x 24	3.9 / 9.8
				6.75 x 19.5	2.6 / 6.4	6.75 x 19.5	2.9 / 7.2	6.75 x 21	3.2 / 7.9	6.75 x 22.5	3.4 / 8.4				

See General Notes on page 25.

## Garage Door Header Roof Span Tables

See General Notes on page 25.

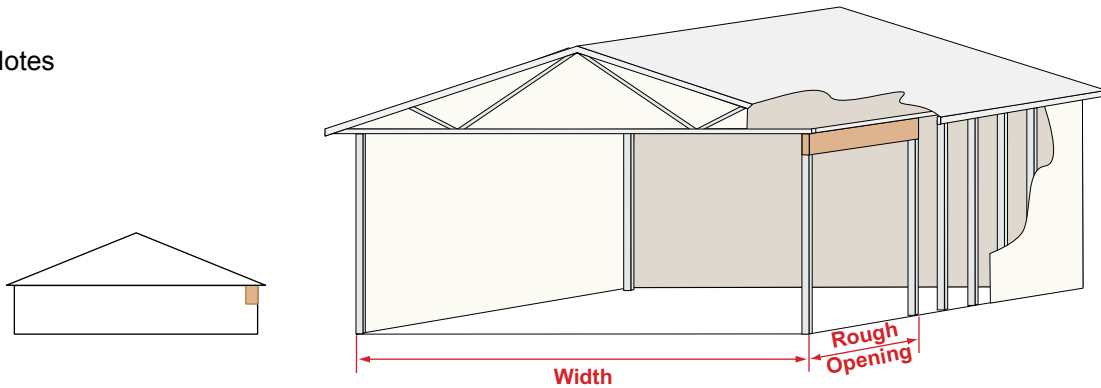

### Required Beam Depths and Bearing Lengths [in]

Load Duration %	Roof Load [psf]		Width of Bldg Segment [Feet]	Clear Span [feet]											
	Live	Dead		KEY: Beam Breadth [in] X Beam Depth [in] End Support Length Requirements [in]											
				8'-3"		9'-3"		10'-0"		12'-0"		16'-3"		18'-3"	
125	20	15	24	3.125 x 6	1.5	3.125 x 7.5	1.5	3.125 x 7.5	1.5	3.125 x 9	1.5	3.125 x 12	2.0	3.125 x 13.5	2.3
				5.125 x 6	1.5	5.125 x 6	1.5	5.125 x 7.5	1.5	5.125 x 7.5	1.5	5.125 x 10.5	1.5	5.125 x 12	1.5
			30	3.125 x 7.5	1.5	3.125 x 7.5	1.5	3.125 x 9	1.5	3.125 x 10.5	1.8	3.125 x 13.5	2.4	3.125 x 15	2.7
				5.125 x 6	1.5	5.125 x 7.5	1.5	5.125 x 7.5	1.5	5.125 x 9	1.5	5.125 x 12	1.5	5.125 x 12	1.7
			36	3.125 x 7.5	1.5	3.125 x 9	1.7	3.125 x 9	1.8	3.125 x 10.5	2.1	3.125 x 15	2.9	3.125 x 16.5	3.2
				5.125 x 6	1.5	5.125 x 7.5	1.5	5.125 x 7.5	1.5	5.125 x 9	1.5	5.125 x 12	1.8	5.125 x 13.5	2.0
115	25	15	24	3.125 x 7.5	1.5	3.125 x 7.5	1.5	3.125 x 9	1.5	3.125 x 10.5	1.7	3.125 x 13.5	2.3	3.125 x 15	2.6
				5.125 x 6	1.5	5.125 x 6	1.5	5.125 x 7.5	1.5	5.125 x 9	1.5	5.125 x 10.5	1.5	5.125 x 12	1.6
			30	3.125 x 7.5	1.5	3.125 x 9	1.6	3.125 x 9	1.7	3.125 x 10.5	2.1	3.125 x 15	2.8	3.125 x 16.5	3.1
				5.125 x 6	1.5	5.125 x 7.5	1.5	5.125 x 7.5	1.5	5.125 x 9	1.5	5.125 x 12	1.7	5.125 x 13.5	1.9
			36	3.125 x 7.5	1.7	3.125 x 9	1.9	3.125 x 10.5	2.0	3.125 x 12	2.4	3.125 x 16.5	3.3	3.125 x 18	3.7
				5.125 x 7.5	1.5	5.125 x 7.5	1.5	5.125 x 7.5	1.5	5.125 x 9	1.5	5.125 x 12	2.0	5.125 x 13.5	2.3
115	30	15	24	3.125 x 7.5	1.5	3.125 x 9	1.5	3.125 x 9	1.6	3.125 x 10.5	1.9	3.125 x 13.5	2.6	3.125 x 16.5	2.9
				5.125 x 6	1.5	5.125 x 7.5	1.5	5.125 x 7.5	1.5	5.125 x 9	1.5	5.125 x 12	1.6	5.125 x 13.5	1.8
			30	3.125 x 9	1.6	3.125 x 9	1.8	3.125 x 10.5	2.0	3.125 x 12	2.3	3.125 x 15	3.1	3.125 x 18	3.5
				5.125 x 6	1.5	5.125 x 7.5	1.5	5.125 x 7.5	1.5	5.125 x 9	1.5	5.125 x 12	1.9	5.125 x 13.5	2.2
			36	3.125 x 9	1.9	3.125 x 10.5	2.1	3.125 x 10.5	2.3	3.125 x 12	2.7	3.125 x 16.5	3.7	3.125 x 18	4.1
				5.125 x 7.5	1.5	5.125 x 7.5	1.5	5.125 x 9	1.5	5.125 x 10.5	1.7	5.125 x 13.5	2.3	5.125 x 15	2.5
115	40	15	24	3.125 x 9	1.6	3.125 x 9	1.8	3.125 x 10.5	2.0	3.125 x 12	2.3	3.125 x 15	3.2	3.125 x 18	3.5
				5.125 x 6	1.5	5.125 x 7.5	1.5	5.125 x 7.5	1.5	5.125 x 9	1.5	5.125 x 12	1.9	5.125 x 13.5	2.2
			30	3.125 x 9	2.0	3.125 x 10.5	2.2	3.125 x 10.5	2.4	3.125 x 13.5	2.8	3.125 x 16.5	3.8	5.125 x 15	4.3
				5.125 x 7.5	1.5	5.125 x 7.5	1.5	5.125 x 9	1.5	5.125 x 10.5	1.8	5.125 x 13.5	2.3	6.75 x 13.5	2.0
			36	3.125 x 9	2.3	3.125 x 10.5	2.6	3.125 x 12	2.8	3.125 x 13.5	3.3	3.125 x 18	4.5	5.125 x 16.5	5.0
				5.125 x 7.5	1.5	5.125 x 9	1.6	5.125 x 9	1.7	5.125 x 10.5	2.1	5.125 x 15	2.8	6.75 x 15	2.4

See General Notes on page 25.

## Ridge Beam Span Tables

See General Notes on page 25.

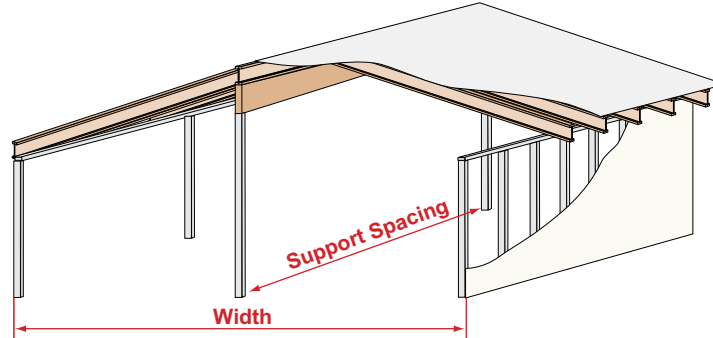
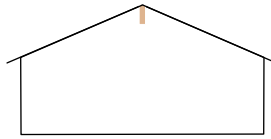

**Vertical Holes for Wiring:** When designing ridge beams where fixtures may be attached (ceiling fans or lights), a beam may be up-sized in width or depth to accommodate a single vertical hole. For example, if a 3 1/8" x 12" beam is structurally adequate from the table below, a single vertical hole may only be drilled in either a 3 1/8" x 13 1/2" or 5 1/8" x 12" beam in the same application. This provision only applies to the ridge beam table below. A single vertical hole may only be drilled in the middle 1/3rd of the span, the middle of the beam's cross-section, and be drilled straight in a craftsmanlike manner. Maximum vertical hole diameter is: 1/2" for 3 1/8" wide beams, 3/4" for 5 1/8", 6 3/4" and 8 3/4" beams. For other applications and/or sizes, contact Boise EWP Engineering.

### Required Beam Depths and Bearing Lengths [in]

Load Duration %	Roof Load [psf]		Width of Bldg Segment [Feet]	Ridge Beam Support Spacing [feet]							
	Live	Dead		KEY: Beam Breadth [in] X Beam Depth [in]				End Support/Intermediate Support Bearing Length Requirements [in]			
				12		16		20		24	
125	20	15	24	3.125 x 10.5	1.5 / 3.8	3.125 x 13.5	2.0 / 5	3.125 x 16.5	2.5 / 6.2	5.125 x 16.5	1.8 / 4.5
				5.125 x 9	1.5 / 3	5.125 x 10.5	1.5 / 3.1	5.125 x 13.5	1.6 / 3.8	6.75 x 15	1.5 / 3.5
			30	3.125 x 12	1.9 / 4.7	3.125 x 15	2.5 / 6.2	3.125 x 18	3.1 / 7.8	5.125 x 18	2.3 / 5.7
				5.125 x 9	1.5 / 3	5.125 x 12	1.6 / 3.8	5.125 x 15	1.9 / 4.7	6.75 x 16.5	1.8 / 4.3
			36	3.125 x 12	2.3 / 5.6	3.125 x 16.5	3.0 / 7.5	5.125 x 16.5	2.3 / 5.7	5.125 x 19.5	2.7 / 6.8
				5.125 x 10.5	1.5 / 3.5	5.125 x 13.5	1.9 / 4.6	6.75 x 15	1.8 / 4.3	6.75 x 18	2.1 / 5.2
115	25	15	24	3.125 x 12	1.7 / 4.2	3.125 x 15	2.3 / 5.6	3.125 x 18	2.8 / 7	5.125 x 18	2.1 / 5.1
				5.125 x 9	1.5 / 3	5.125 x 12	1.5 / 3.4	5.125 x 15	1.7 / 4.3	6.75 x 16.5	1.6 / 3.9
			30	3.125 x 12	2.1 / 5.3	3.125 x 16.5	2.8 / 7	5.125 x 16.5	2.2 / 5.3	5.125 x 19.5	2.6 / 6.4
				5.125 x 10.5	1.5 / 3.2	5.125 x 13.5	1.7 / 4.3	6.75 x 15	1.6 / 4	6.75 x 18	2 / 4.8
			36	3.125 x 13.5	2.6 / 6.3	3.125 x 18	3.4 / 8.4	5.125 x 18	2.6 / 6.4	5.125 x 22.5	3.1 / 7.6
				5.125 x 10.5	1.6 / 3.9	5.125 x 15	2.1 / 5.1	6.75 x 16.5	2 / 4.8	6.75 x 19.5	2.3 / 5.8
115	30	15	24	3.125 x 12	1.9 / 4.7	3.125 x 15	2.5 / 6.2	5.125 x 15	1.9 / 4.7	5.125 x 19.5	2.3 / 5.6
				5.125 x 10.5	1.5 / 3	5.125 x 12	1.5 / 3.8	6.75 x 13.5	1.5 / 3.6	6.75 x 16.5	1.7 / 4.3
			30	3.125 x 13.5	2.4 / 5.8	3.125 x 18	3.1 / 7.7	5.125 x 18	2.4 / 5.9	5.125 x 21	2.8 / 7
				5.125 x 10.5	1.5 / 3.6	5.125 x 13.5	1.9 / 4.7	6.75 x 15	1.8 / 4.5	6.75 x 18	2.2 / 5.4
			36	3.125 x 15	2.8 / 7	5.125 x 15	2.3 / 5.7	5.125 x 19.5	2.9 / 7.1	5.125 x 22.5	3.4 / 8.4
				5.125 x 12	1.7 / 4.3	6.75 x 13.5	1.8 / 4.3	6.75 x 16.5	2.2 / 5.4	6.75 x 21	2.6 / 6.4
115	40	15	24	3.125 x 13.5	2.3 / 5.6	3.125 x 16.5	3.0 / 7.4	5.125 x 16.5	2.3 / 5.6	5.125 x 21	2.7 / 6.7
				5.125 x 10.5	1.5 / 3.4	5.125 x 13.5	1.8 / 4.5	6.75 x 15	1.7 / 4.3	6.75 x 18	2.1 / 5.1
			30	3.125 x 15	2.8 / 7	5.125 x 15	2.3 / 5.6	5.125 x 19.5	2.8 / 7	5.125 x 22.5	3.4 / 8.4
				5.125 x 12	1.7 / 4.3	6.75 x 13.5	1.8 / 4.3	6.75 x 16.5	2.2 / 5.3	6.75 x 21	2.6 / 6.4
			36	3.125 x 16.5	3.4 / 8.4	5.125 x 16.5	2.7 / 6.8	5.125 x 21	3.4 / 8.4	6.75 x 22.5	3.1 / 7.7
				5.125 x 12	2.1 / 5.1	6.75 x 15	2.1 / 5.2	6.75 x 18	2.6 / 6.4		

See General Notes on page 25.

## Roof and One Floor Span Tables

See General Notes on page 25.

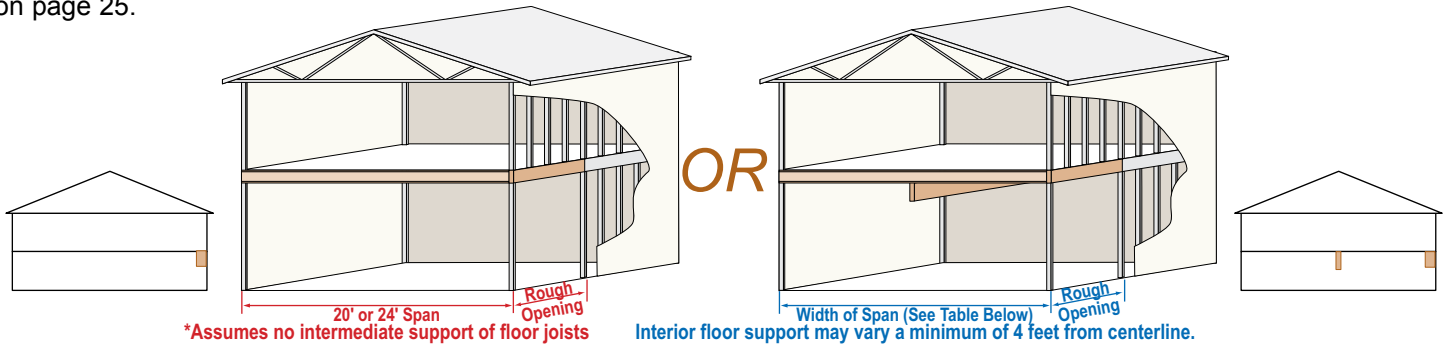

Total load deflection limited to  $\frac{5}{16}$ " for window considerations

Load Duration %	Roof Load [psf]		Width of Bldg Segment [Feet]	Clear Span [feet]					
	Live	Dead		KEY: Beam Breadth [in] X Beam Depth [in] End Support Length Requirements [in]					
				6'-3"		9'-3"		12'-3"	
125	20	15	24	3.125 x 7.5	1.8	3.125 x 12	2.4	3.125 x 16.5	3.1
				5.125 x 6	1.5	5.125 x 10.5	1.5	5.125 x 13.5	1.9
			30	3.125 x 7.5	1.9	3.125 x 12	2.8	3.125 x 16.5	3.7
				5.125 x 6	1.5	5.125 x 10.5	1.7	5.125 x 13.5	2.3
			36	3.125 x 7.5	2.2	3.125 x 12	3.2	3.125 x 18	4.2
				5.125 x 6	1.5	5.125 x 10.5	2.0	5.125 x 15	2.6
115	25	15	24	3.125 x 7.5	2.0	3.125 x 12	2.5	3.125 x 16.5	3.3
				5.125 x 6	1.5	5.125 x 10.5	1.6	5.125 x 13.5	2.0
			30	3.125 x 7.5	2.0	3.125 x 12	3.0	3.125 x 18	3.9
				5.125 x 6	1.5	5.125 x 10.5	1.8	5.125 x 15	2.4
			36	3.125 x 9	2.4	3.125 x 13.5	3.4	3.125 x 18	4.5
				5.125 x 7.5	1.5	5.125 x 10.5	2.1	5.125 x 15	2.8
115	30	15	24	3.125 x 9	2.2	3.125 x 12	2.7	3.125 x 16.5	3.5
				5.125 x 6	1.5	5.125 x 10.5	1.7	5.125 x 15	2.2
			30	3.125 x 9	2.2	3.125 x 12	3.2	3.125 x 18	4.2
				5.125 x 7.5	1.5	5.125 x 10.5	2.0	5.125 x 15	2.6
			36	3.125 x 9	2.5	3.125 x 13.5	3.7	3.125 x 18	4.8
				5.125 x 7.5	1.6	5.125 x 10.5	2.3	5.125 x 16.5	3.0
115	40	15	24	3.125 x 9	2.4	3.125 x 12	3.0	3.125 x 18	4.0
				5.125 x 7.5	1.5	5.125 x 10.5	1.9	5.125 x 15	2.4
			30	3.125 x 9	2.4	3.125 x 13.5	3.6	3.125 x 18	4.7
				5.125 x 7.5	1.5	5.125 x 10.5	2.2	5.125 x 16.5	2.9
			36	3.125 x 9	2.8	3.125 x 13.5	4.1	5.125 x 16.5	3.3
				5.125 x 7.5	1.7	5.125 x 12	2.5	6.75 x 15	2.6

See General Notes on page 25.

# BOISE GLULAM® Beams Substitution Tables

## BOISE GLULAM® — Steel W Shape Substitution Table

### Floor Beam Applications (100%) Duration for BOISE GLULAM®

#### 24F-V4 BOISE GLULAM® Equivalent Member

Span [ft]	W 6x9	W 8x10	W 12x14	W 12x16	W 12x19	W 10x 22	W 12x22	W 14x22	W 12x26	W 14x26	W16x26	W 12x30
10	3.125 x 10.5	3.125 x 13.5	3.125 x 18									
	5.125 x 9	5.125 x 10.5	5.125 x 13.5	5.125 x 15	5.125 x 16.5	5.125 x 16.5	5.125 x 18	5.125 x 19.5	5.125 x 21	5.125 x 22.5	5.125 x 24	5.125 x 24
12	3.125 x 10.5	3.125 x 13.5	3.125 x 18									
	5.125 x 9	5.125 x 10.5	5.125 x 13.5	5.125 x 15	5.125 x 16.5	5.125 x 16.5	5.125 x 18	5.125 x 19.5	5.125 x 21	5.125 x 21	5.125 x 22.5	5.125 x 22.5
14	3.125 x 10.5	3.125 x 13.5	3.125 x 18									
	5.125 x 9	5.125 x 10.5	5.125 x 13.5	5.125 x 15	5.125 x 16.5	5.125 x 16.5	5.125 x 18	5.125 x 19.5	5.125 x 21	5.125 x 21	5.125 x 22.5	5.125 x 22.5
16	3.125 x 10.5	3.125 x 13.5	3.125 x 18									
	5.125 x 9	5.125 x 10.5	5.125 x 15	5.125 x 15	5.125 x 16.5	5.125 x 16.5	5.125 x 18	5.125 x 19.5	5.125 x 21	5.125 x 21	5.125 x 22.5	5.125 x 22.5
18	3.125 x 10.5	3.125 x 13.5	3.125 x 18									
	5.125 x 9	5.125 x 10.5	5.125 x 15	5.125 x 16.5	5.125 x 16.5	5.125 x 16.5	5.125 x 18	5.125 x 19.5	5.125 x 21	5.125 x 21	5.125 x 22.5	5.125 x 22.5
20	3.125 x 10.5	3.125 x 13.5	3.125 x 18									
	5.125 x 9	5.125 x 10.5	5.125 x 15	5.125 x 16.5	5.125 x 18	5.125 x 16.5	5.125 x 18	5.125 x 19.5	5.125 x 21	5.125 x 21	5.125 x 22.5	5.125 x 22.5
22	3.125 x 10.5	3.125 x 13.5	3.125 x 18									
	5.125 x 9	5.125 x 10.5	5.125 x 15	5.125 x 16.5	5.125 x 18	5.125 x 16.5	5.125 x 19.5	5.125 x 19.5	5.125 x 21	5.125 x 21	5.125 x 22.5	5.125 x 22.5
24	3.125 x 10.5	3.125 x 13.5	3.125 x 18									
	5.125 x 9	5.125 x 10.5	5.125 x 16.5	5.125 x 16.5	5.125 x 18	5.125 x 16.5	5.125 x 19.5	5.125 x 21	5.125 x 21	5.125 x 21	5.125 x 22.5	5.125 x 21
26	3.125 x 10.5	3.125 x 13.5	3.125 x 18									
	5.125 x 9	5.125 x 10.5	5.125 x 16.5	5.125 x 16.5	5.125 x 18	5.125 x 16.5	5.125 x 19.5	5.125 x 21	5.125 x 21	5.125 x 21	5.125 x 22.5	5.125 x 21
28	3.125 x 10.5	3.125 x 13.5	3.125 x 18									
	5.125 x 9	5.125 x 10.5	5.125 x 16.5	5.125 x 16.5	5.125 x 18	5.125 x 16.5	5.125 x 19.5	5.125 x 21	5.125 x 21	5.125 x 21	5.125 x 22.5	5.125 x 21
30	3.125 x 10.5	3.125 x 13.5	3.125 x 18									
	5.125 x 9	5.125 x 10.5	5.125 x 16.5	5.125 x 16.5	5.125 x 18	5.125 x 16.5	5.125 x 19.5	5.125 x 21	5.125 x 21	5.125 x 21	5.125 x 22.5	5.125 x 21
32	3.125 x 10.5	3.125 x 13.5	3.125 x 18									
	5.125 x 9	5.125 x 10.5	5.125 x 16.5	5.125 x 16.5	5.125 x 18	5.125 x 16.5	5.125 x 19.5	5.125 x 21	5.125 x 21	5.125 x 21	5.125 x 22.5	5.125 x 21
34	3.125 x 10.5	3.125 x 13.5	3.125 x 18									
	5.125 x 9	5.125 x 10.5	5.125 x 16.5	5.125 x 16.5	5.125 x 18	5.125 x 16.5	5.125 x 19.5	5.125 x 21	5.125 x 21	5.125 x 21	5.125 x 22.5	5.125 x 21
36	3.125 x 10.5	3.125 x 13.5	3.125 x 18									
	5.125 x 9	5.125 x 10.5	5.125 x 16.5	5.125 x 16.5	5.125 x 18	5.125 x 16.5	5.125 x 19.5	5.125 x 21	5.125 x 21	5.125 x 21	5.125 x 22.5	5.125 x 21
38	3.125 x 10.5	3.125 x 13.5	3.125 x 18									
	5.125 x 9	5.125 x 10.5	5.125 x 16.5	5.125 x 16.5	5.125 x 18	5.125 x 16.5	5.125 x 19.5	5.125 x 21	5.125 x 21	5.125 x 21	5.125 x 24	5.125 x 21
40	3.125 x 10.5	3.125 x 13.5	3.125 x 18									
	5.125 x 9	5.125 x 10.5	5.125 x 16.5	5.125 x 16.5	5.125 x 18	5.125 x 16.5	5.125 x 19.5	5.125 x 21	5.125 x 21	5.125 x 21	5.125 x 24	5.125 x 21

### NOTES

- Table intended for preliminary design only. Substitutions should always be approved by the project's design professional of record.
- Table assumes that original steel W section was sized properly, loading should always be verified.
- Table was developed by comparing allowable uniform load capacities due to the worst case control of bending, shear and deflection limits for simple span applications. Beam weights are considered.
- Deflection limited to L/360 for live load, based upon a live load/total load ratio of 0.8 (residential floor loading 40/10 psf).
- Steel W Section Allowable Design Values:  $F_b = 0.66 \times 36$  ksi,  $F_v = 0.4 \times 36$  ksi, MOE =  $29 \times 10^6$  ksi (allowable stress design assumed).
- Steel Information - W Section Nomenclature: 1st number = approximate depth [in], 2nd number = weight per foot [lb/ft].

## BOISE GLULAM® — Douglas Fir-Larch Solid Sawn Substitution Table

### Floor Beam Applications (100%) Duration for BOISE GLULAM®

#### 24F-V4 BOISE GLULAM® Equivalent Member

Span [ft]	4x6 Doug Fir-Larch		4x8 Doug Fir-Larch		4x10 Doug Fir-Larch		4x12 Doug Fir-Larch		6x8 Doug Fir-Larch		6x10 Doug Fir-Larch		6x12 Doug Fir-Larch	
	Select Structural	No. 1	Select Structural	No. 1	Select Structural	No. 1	Select Structural	No. 1	Select Structural	No. 1	Select Structural	No. 1	Select Structural	No. 1
10	3.125 x 6	3.125 x 6	3.125 x 7.5	3.125 x 7.5	3.125 x 9	3.125 x 9	3.125 x 9	3.125 x 9	3.125 x 9	3.125 x 9	3.125 x 10.5	3.125 x 10.5	3.125 x 10.5	3.125 x 10.5
									5.125 x 7.5	5.125 x 7.5	5.125 x 9	5.125 x 9	5.125 x 9	5.125 x 9
12	3.125 x 6	3.125 x 6	3.125 x 9	3.125 x 7.5	3.125 x 10.5	3.125 x 9	3.125 x 10.5	3.125 x 10.5	3.125 x 9	3.125 x 9	3.125 x 10.5	3.125 x 10.5	3.125 x 12	3.125 x 12
									5.125 x 7.5	5.125 x 7.5	5.125 x 9	5.125 x 9	5.125 x 10.5	5.125 x 10.5
14	3.125 x 6	3.125 x 6	3.125 x 9	3.125 x 7.5	3.125 x 10.5	3.125 x 9	3.125 x 12	3.125 x 10.5	3.125 x 9	3.125 x 9	3.125 x 12	3.125 x 10.5	3.125 x 13.5	3.125 x 12
									5.125 x 7.5	5.125 x 7.5	5.125 x 10.5	5.125 x 9	5.125 x 10.5	5.125 x 10.5
16	3.125 x 6	3.125 x 6	3.125 x 9	3.125 x 7.5	3.125 x 10.5	3.125 x 9	3.125 x 12	3.125 x 10.5	3.125 x 9	3.125 x 9	3.125 x 12	3.125 x 12	3.125 x 13.5	3.125 x 13.5
									5.125 x 7.5	5.125 x 7.5	5.125 x 10.5	5.125 x 10.5	5.125 x 12	5.125 x 12
18	3.125 x 6	3.125 x 6	3.125 x 9	3.125 x 7.5	3.125 x 10.5	3.125 x 10.5	3.125 x 12	3.125 x 10.5	3.125 x 9	3.125 x 9	3.125 x 12	3.125 x 12	3.125 x 13.5	3.125 x 13.5
									5.125 x 7.5	5.125 x 7.5	5.125 x 10.5	5.125 x 10.5	5.125 x 12	5.125 x 12
20	3.125 x 6	3.125 x 6	3.125 x 9	3.125 x 7.5	3.125 x 10.5	3.125 x 10.5	3.125 x 12	3.125 x 12	3.125 x 9	3.125 x 9	3.125 x 12	3.125 x 12	3.125 x 13.5	3.125 x 13.5
									5.125 x 7.5	5.125 x 7.5	5.125 x 10.5	5.125 x 10.5	5.125 x 12	5.125 x 12
22	3.125 x 6	3.125 x 6	3.125 x 9	3.125 x 7.5	3.125 x 10.5	3.125 x 10.5	3.125 x 12	3.125 x 12	3.125 x 9	3.125 x 9	3.125 x 12	3.125 x 12	3.125 x 13.5	3.125 x 13.5
									5.125 x 7.5	5.125 x 7.5	5.125 x 10.5	5.125 x 10.5	5.125 x 12	5.125 x 12
24	3.125 x 6	3.125 x 6	3.125 x 9	3.125 x 7.5	3.125 x 10.5	3.125 x 10.5	3.125 x 12	3.125 x 12	3.125 x 9	3.125 x 9	3.125 x 10.5	3.125 x 10.5	3.125 x 13.5	3.125 x 13.5
									5.125 x 7.5	5.125 x 7.5	5.125 x 10.5	5.125 x 10.5	5.125 x 12	5.125 x 12

### NOTES

- Table intended for preliminary design only. Substitutions should always be approved by the project's design professional of record.
- Table was developed by comparing allowable uniform load capacities due to the worst case control of bending, shear and deflection limits for simple span applications.
- Table assumes that original solid sawn beam was sized properly, loading should always be verified.
- Deflection limited to L/360 for live load, based upon a live load/total load ratio of 0.8 (residential floor loading 40/10 psf).

# BOISE GLULAM® Beams Hanger Tables

## BOISE GLULAM® BEAM HANGERS



Width	Depth	Top Mount Hanger		Face Mount Hanger	
		Model No. <sup>(1)</sup>	Allow Load (Floor 100%)	Model No. <sup>(1)</sup>	Allow Load (Floor 100%)
3 1/8"	6"	HW3.25X	5285	HU26-2	1610
	7 1/2"	GLT3	8165	HU28-2	1875
	9" - 10 1/2"	GLT3	8165	HGUS3.25/10	8780
	12"	GLT3	8165	HGUS3.25/12	9155
	13 1/2" - 18"	HGLT3	11590	HGUS3.25/12	9155
3 1/2"	7 1/2"	HW3.56X	5285	HGUS48	6805
	9"	GLTV4	7000	HGUS48	6805
	10 1/2" - 12"	GLTV4	7000	HGUS412	9155
	13 1/2" - 15"	HGLTV4	8665	HGUS414	10015
5 1/8"	6"	HW5.25X	5285	HU38-2	2015
	7 1/2"	GLT5	8165	HU38-2	2015
	9"	GLT5	8165	HU310-2	2015
	10 1/2" - 12"	GLT5	8165	HGUS5.25/12	9155
	13 1/2" - 16 1/2"	HGLT5	11930	HGUS5.25/12	9155
	18" - 19 1/2"	MEG5	19710	HGUS5.25/12	9155
	21" - 24"	EG5	20895	--- <sup>4</sup>	---
5 1/2"	9" - 10 1/2"	GLTV6	7000	HGUS5.50/10	8780
	12"	GLTV6	7000	HGUS5.50/12	9155
6 3/4"	7 1/2"	GLT7	8165	--- <sup>4</sup>	---
	9" - 10 1/2"	GLT7	8165	HGUS6.88/10	8780
	12"	GLT7	8165	HGUS6.88/12	9835
	13 1/2" - 16 1/2"	HGLT7	11930	HGUS6.88/14	11110
	18" - 24"	EG7	25320	HGU7.00	14060
8 3/4"	9" - 10 1/2"	HGLT9	12750	--- <sup>4</sup>	---
	12" - 15"	HGLT9	12750	HGU9.00	14060

- 1) Specify height when ordering.
- 2) Specify width when ordering.
- 3) Loads assume Douglas Fir-Larch/Douglas Fir-Larch configuration, adjust accordingly for other wood species.
- 4) Consult current Simpson products catalog for required fasteners, design values and other information at 1-800-999-5099 or visit their website at [www.strongtie.com](http://www.strongtie.com).

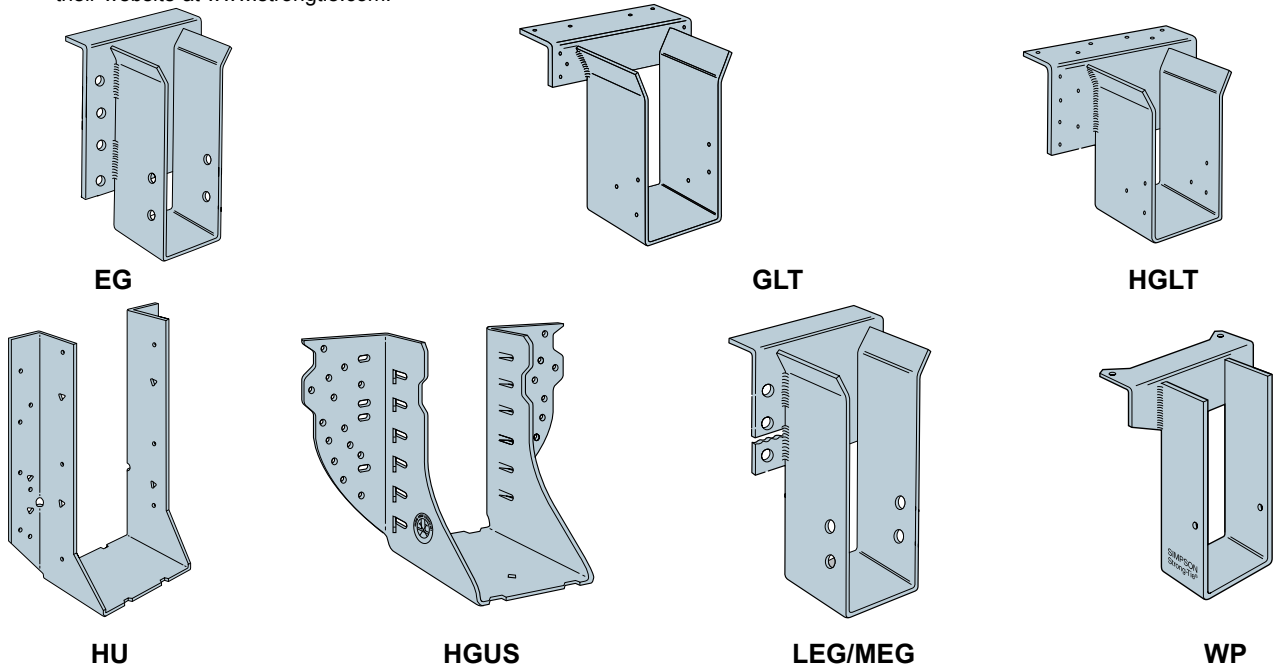

# BOISE GLULAM® Beams Hanger Tables



## BOISE GLULAM® BEAM HANGERS

Width	Depth	Top Mount Hanger		Face Mount Hanger	
		Model No. <sup>(1)</sup>	Allow Load (Floor 100%)	Model No. <sup>(1)</sup>	Allow Load (Floor 100%)
3 1/8"	6"	KHW3	5295	HD26-2	1680
	7 1/2"	KGLT3	7545	HD28-2	1960
	9" - 10 1/2"	KGLT3	7545	THDH3210	8170
	12"	KGLT3	7545	THDH3212	9870
	13 1/2" - 18"	KHGLT3	12965	THDH3212	9870
3 1/2"	7 1/2"	KGLT4	7545	THDH48	6465
	9"	KGLT4	7545	THDH410	8170
	10 1/2" - 12"	KGLT4	7545	THDH412	9875
	13 1/2" - 15"	KGLT4	7545	THDH414	11100
5 1/8"	6"	KGLT5	7545	THDH26-3	3880
	7 1/2"	KGLT5	7545	THDH28-3	6465
	9"	KGLT5	7545	THDH5210	8640
	10 1/2"	KGLT5	7545	THDH5210	8640
	12"	KGLT5	7545	THDH5212	9935
	13 1/2" - 16 1/2"	KHGLT5	12965	THDH614	11645
	18" - 19 1/2"	KMEG5	12185	THDH614	11645
5 1/2"	9" - 10 1/2"	KEG5	16115	THDH614	11645
	12"	KGLT6	7545	THDH610	8640
	12"	KGLT6	7545	THDH612	9935
6 3/4"	7 1/2"	KGLT7	7545	GHF67750	3505
	9" - 10 1/2"	KGLT7	7545	THDH6710	8170
	12"	KGLT7	7545	THDH6712	9875
	13 1/2" - 16 1/2"	KHGLT7	13400	THDH6714	11580
	18" - 24"	KEG7	17005	THDH6714	11580
8 3/4"	9" - 15"	KHGLT9	13400	-- --	-- --

- Specify height when ordering.
- Loads assume Douglas Fir-Larch header/joist material, adjust for other species.
- KGLT load values based on 460 psi perpendicular to grain loading. KHGLT load values based on 625 psi perpendicular to grain loading.
- Loads depicted are for 100% duration of load factors. Refer to USP Full Line Catalog for load values applicable to other durations of load.
- KEG and KMEG load values are for a supporting member with a width of 5 1/2" and 460 psi perpendicular to grain loading in single shear.
- For additional product information on loading, web stiffeners, nail schedules, and code evaluations, call 1-800-328-5934 or visit their website @ [www.USPconnectors.com](http://www.USPconnectors.com).

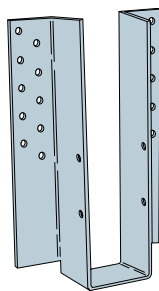

GHF

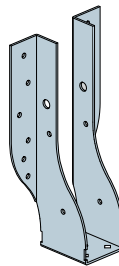

HD

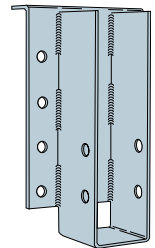

KEG

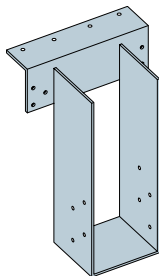

KGLT

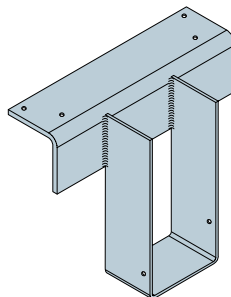

KHW

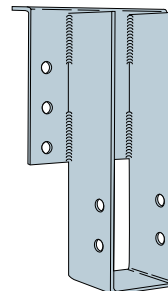

KMEG

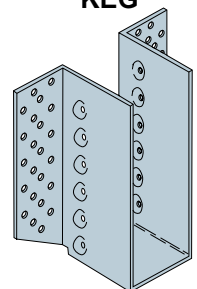

THDH

## BC FRAMER® CADD Framing Software

BC FRAMER® is an easy-to-use, stand-alone computer-aided drafting program with 3D capability designed to quickly create floor and roof framing layouts.

Draw walls, add framing areas, locate beams and rough openings, define cross-sections and on-center spacing. In minutes, BC FRAMER® frames your layout, builds a piece and price report, creates a framing drawing with schedule, all using Boise Cascade Engineered Wood Products.

Easy-to-use editing and drawing tools allow flexibility when modifying members and adding details, symbols and accessories.

Training classes for BC FRAMER® are provided at Boise Cascade's training centers located in Oregon, Louisiana and Georgia.

For questions, comments or a free demonstration CD visit our website at [www.BC.com/ewp](http://www.BC.com/ewp) or email us at [EWPSupport@BC.com](mailto:EWPSupport@BC.com). Information can also be obtained at 1-800-405-5969.

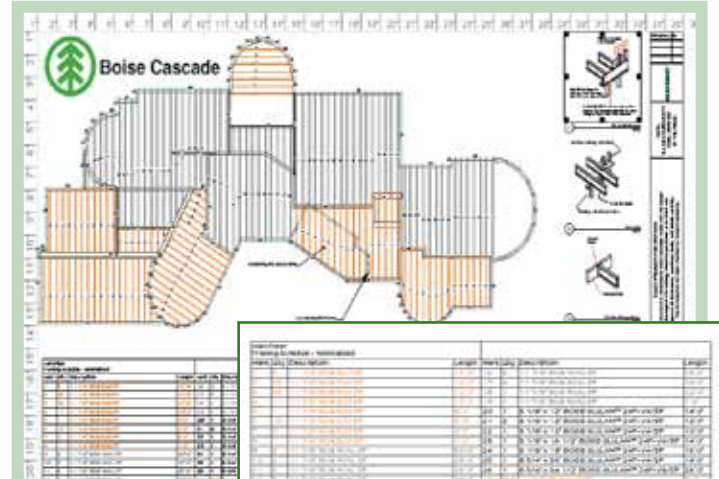

### RECOMMENDED HARDWARE

- Current Pentium Processor
- 2GB RAM (min.)
- Microsoft® Intellimouse
- Windows 7, Vista or XP Professional

Improvements in capacity or speed of these components will yield better performance.

Give Us  
a Try!



## BC CALC® Sizing Software

BC CALC® performs engineering analysis to help our customers size beams and I-joists for their building projects. It is simple to use, yet flexible enough to analyze most joist and beam applications. The user enters span, load, and hole information, and the program determines which of Boise's engineered wood products are necessary for the project.

After the analysis has been run, the user may print an easy-to-read design report that clearly shows span and load information as well as analysis results.

The program includes a comprehensive [Help](#) menu.

BC CALC® is available to designers, architects and engineers on CD-ROM or by download at [www.BCewp.com](http://www.BCewp.com). Hardware requirements include Pentium® Processor with a recommended minimum of 1GB RAM. To order BC CALC®, call 1-800-405-5969 or email [EWPSupport@BC.com](mailto:EWPSupport@BC.com).

To request a CD or Download of BC CALC US, <http://www.bc.com/wood/ewp/software/bccalc/order/US-calc-form.html>

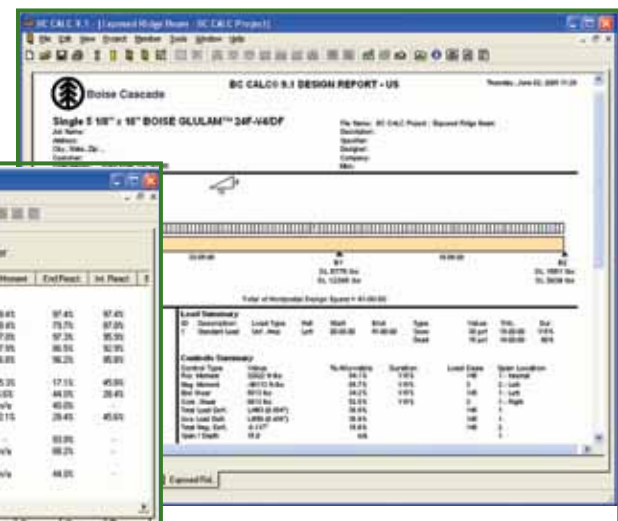
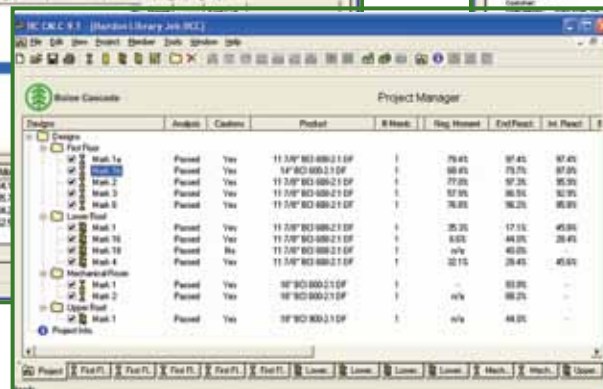
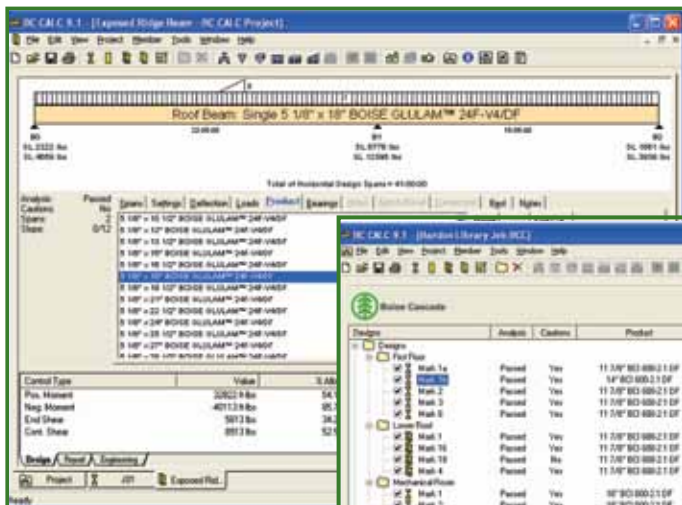

## BC COLUMN™

Boise Cascade EWP is proud to introduce BC COLUMN™. BC COLUMN™ is new software that will allow customers the ability to design columns using Boise Cascade Engineered Wood Products.



### Using BC COLUMN™, users can quickly:

- Design a column or stud using Boise Engineered Wood Products.
- Add gravity and out-of-plane lateral loads.
- Add bracing/supports.
- Select and test products in the design.
- Refine performance factors.
- Print design reports.

### The steps are simple. To use:

- Set up the project:
- Launch BC Column.
- Enter project information.
- Specify the design and select a product.
- Describe the type of column or stud, its height and its bracing.
- Adjust the axial load and add additional out-of-plane lateral loads.
- Select a product. Specify the Deflection.
- Specify the column/stud deflection.
- Analyze and refine designs.
- Review and print design reports.

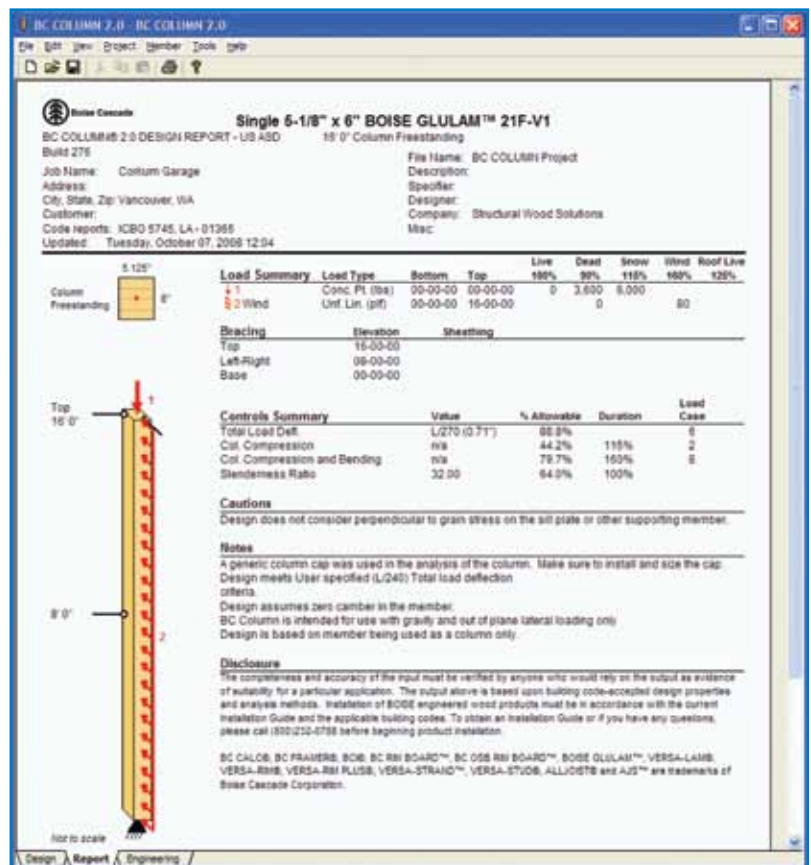
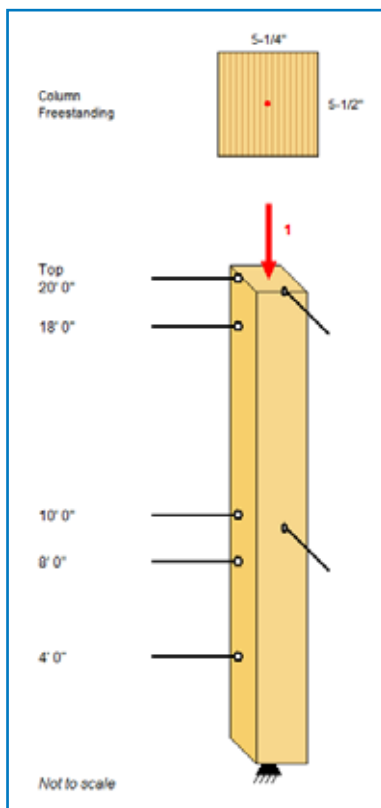
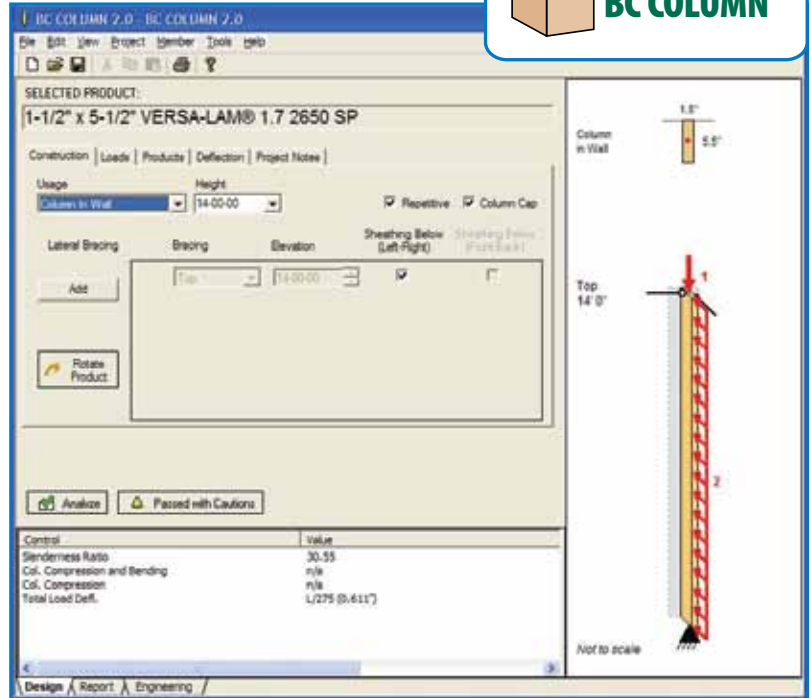

BC COLUMN is installed with BC CALC for the US market ONLY. To request a CD or Download of BC CALC/BC COLUMN US <http://www.bc.com/wood/ewp/software/bccalc/order/US-form.html>

For information about Boise Cascade's engineered wood products, including sales terms and conditions, warranties and disclaimers, visit our website at [www.BCewp.com](http://www.BCewp.com)



American Institute  
of  
Timber Construction

**Documents:**

ANSI/AITC Standards A190.1-2002 American National Standard for Structural Glued Laminated Timber

Guidelines for the Analysis of Drilled Holes or Notches in Structural Glued Laminated Timber Beams, TN-19

Evaluation of Checking in Glued Laminated Timbers, TN-18

Standard for Heavy Timber Construction, AITC 108



Boise Cascade has a proven track record of providing quality wood products and a nationwide building materials distribution network for our customers, helping them to enhance their own businesses.

Boise Cascade Engineered Wood Products build better homes with stronger, stiffer floors using only wood purchased in compliance with a number of green building programs. Take a moment to view our sustainability certification site at <http://www.bc.com/sustainability/certification.html> or view our green brochure at [http://www.bc.com/wood/ewp/Boise\\_EWP\\_Green.html](http://www.bc.com/wood/ewp/Boise_EWP_Green.html).

Boise Cascade Engineered Wood Products throughout North America can now be ordered FSC® Chain-of-Custody (COC) certified, enabling homebuilders to achieve LEED® points under U.S. Green Building Council® residential and commercial green building programs including LEED for Homes and LEED for New Construction. Boise Cascade Engineered Wood Products are available as PEFC® Chain-of-Custody certified, SFI® Chain-of-Custody certified and SFI Fiber-Sourcing certified, as well as NAHB Research Center Green Approved, enabling homebuilders to also obtain green building points through the National Green Building Standard.

Your Dealer is:

*If no dealer is listed, call 1-800-237-4013*